

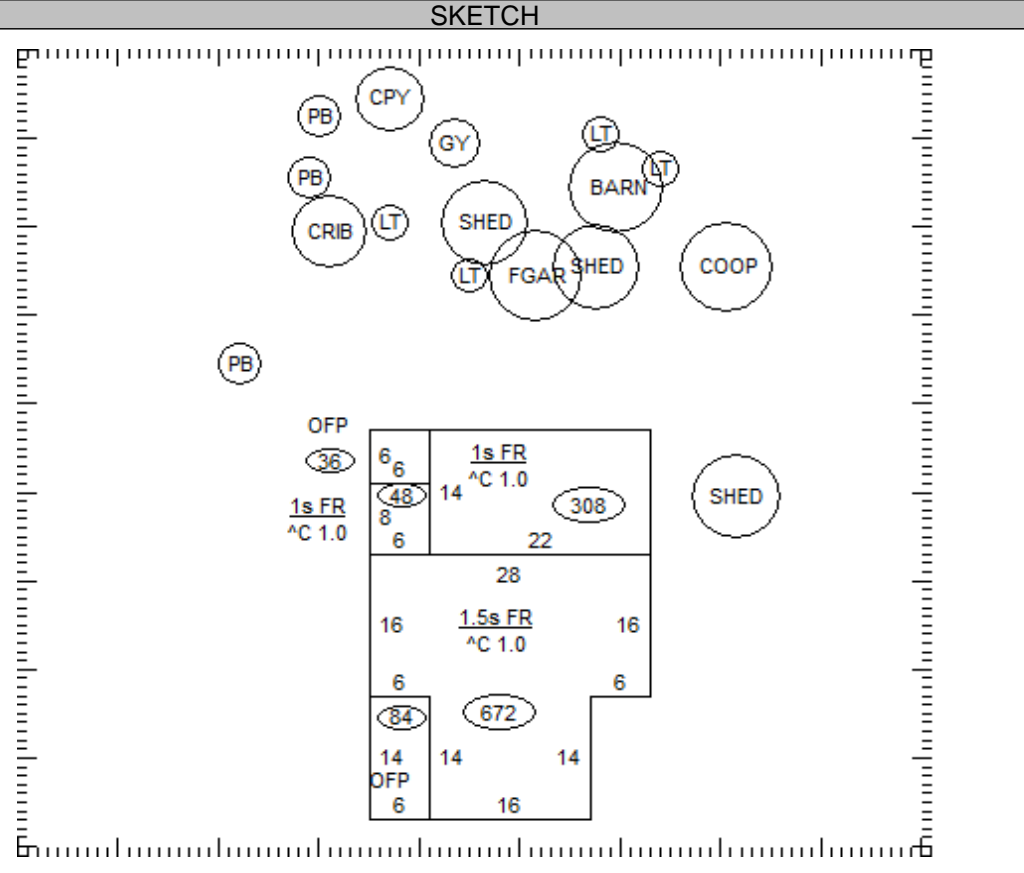

OCCUPANCY		EXTERIOR		FLOOR	AREA	CONST	VALUE
<input checked="" type="checkbox"/> SF	<input type="checkbox"/> DU	<input type="checkbox"/> TR	<input type="checkbox"/> WOOD	1	1028	FR	163,080
<input type="checkbox"/> CONVERSION			<input type="checkbox"/> STUCCO	.5	336	FR	33,060
BUILDING TYPE			<input checked="" type="checkbox"/> ALM/VYNL				
<input type="checkbox"/> MOBILE HOME			<input type="checkbox"/> CONC BLK				
<input type="checkbox"/> BI/TR LEVEL			<input type="checkbox"/> METAL				
<input type="checkbox"/> MOD/MAN			<input type="checkbox"/> BRICK				
<input type="checkbox"/>			<input type="checkbox"/> STONE				
ROOFING		ROOF TYPE					
<input type="checkbox"/> METAL			<input checked="" type="checkbox"/> GABLE				
<input type="checkbox"/> SLT/TLE			<input type="checkbox"/> HIP				
<input checked="" type="checkbox"/> SHINGLES			<input type="checkbox"/> GAMBREL				
<input type="checkbox"/> SHAKES			<input type="checkbox"/> MANSARD				
<input type="checkbox"/> COMPOSITE			<input type="checkbox"/> FLAT				
SUBTOTAL							196,140

FLOORS		B	1	2	3	U	
CONCRETE		<input type="checkbox"/>	<input type="checkbox"/>	<input type="checkbox"/>	<input type="checkbox"/>	<input type="checkbox"/>	
WOOD		<input type="checkbox"/>	<input checked="" type="checkbox"/>	<input checked="" type="checkbox"/>	<input type="checkbox"/>	<input type="checkbox"/>	
TILE/COMPO		<input type="checkbox"/>	<input type="checkbox"/>	<input type="checkbox"/>	<input type="checkbox"/>	<input type="checkbox"/>	
CARPET		<input type="checkbox"/>	<input type="checkbox"/>	<input type="checkbox"/>	<input type="checkbox"/>	<input type="checkbox"/>	
INT. FINISH		B	1	2	3	U	
PLASTER/DW		<input type="checkbox"/>	<input checked="" type="checkbox"/>	<input checked="" type="checkbox"/>	<input type="checkbox"/>	<input type="checkbox"/>	
PANELING		<input type="checkbox"/>	<input type="checkbox"/>	<input type="checkbox"/>	<input type="checkbox"/>	<input type="checkbox"/>	
UNFINISHED		<input type="checkbox"/>	<input type="checkbox"/>	<input type="checkbox"/>	<input type="checkbox"/>	<input type="checkbox"/>	
ACCOMMODATIONS							
# OF ROOMS			3	2			
BEDROOMS			1	2			
FIREPLACES							
HEAT & AC		B	1	2	3	U	
NO HEAT		<input type="checkbox"/>	<input type="checkbox"/>	<input checked="" type="checkbox"/>	<input type="checkbox"/>	<input type="checkbox"/>	
CTRL HEAT		<input type="checkbox"/>	<input checked="" type="checkbox"/>	<input type="checkbox"/>	<input type="checkbox"/>	<input type="checkbox"/>	
HW/STEAM		<input type="checkbox"/>	<input type="checkbox"/>	<input type="checkbox"/>	<input type="checkbox"/>	<input type="checkbox"/>	
ELECTRIC		<input type="checkbox"/>	<input type="checkbox"/>	<input type="checkbox"/>	<input type="checkbox"/>	<input type="checkbox"/>	
HEAT PUMP		<input type="checkbox"/>	<input type="checkbox"/>	<input type="checkbox"/>	<input type="checkbox"/>	<input type="checkbox"/>	
FLR/WALL		<input type="checkbox"/>	<input type="checkbox"/>	<input type="checkbox"/>	<input type="checkbox"/>	<input type="checkbox"/>	
STVE/SPCE		<input type="checkbox"/>	<input type="checkbox"/>	<input type="checkbox"/>	<input type="checkbox"/>	<input type="checkbox"/>	
GEOTHERMAL		<input type="checkbox"/>	<input type="checkbox"/>	<input type="checkbox"/>	<input type="checkbox"/>	<input type="checkbox"/>	
OUTSIDE		<input type="checkbox"/>	<input type="checkbox"/>	<input type="checkbox"/>	<input type="checkbox"/>	<input type="checkbox"/>	
CTRL A/C		<input type="checkbox"/>	<input type="checkbox"/>	<input type="checkbox"/>	<input type="checkbox"/>	<input type="checkbox"/>	
PLUMBING		BASE		<input checked="" type="checkbox"/>			
X FULL BATH							
X HALF BATH							
X FIXTURES							
MULTI-FAMILY #				0			0
BUILDING TYPE				100%			0
BSMT FINISH				0 S.F.			0
FIREPLACE #				0			0
HEATING				336 S.F.			-1,280
AIR COND				0 S.F.			0
PLUMBING #				0			0
GARAGES & CARPORTS							0
EXTRA FEATURES							2,000
SUBTOTAL							196,860
GRADE FACTOR							100 %
UNADJUSTED VALUE							196,860
FACTOR							100 %



OCCUPANCY	ST.HT	SIZE	AREA	GRADE	PRICE	AGE	REMD	CND	UNADJ VAL	PHYS	PHYS VAL	FUNC	TRUE VAL
DWELLING	1.5	SK	1,364	C		1900		A	196,860	45	108,270		108,300
1 Shed	8	10x16	160	D	7.92	2008		A	1,270	26	940		900
2 Pole Bldg	12	30x96	2,880	C	11.15	1977		A	32,110	80	6,420		6,400
3 Barn	14	32x50	1,600	C	12.00	1900		A	19,200	95	960	CDU50	500
4 Shed	8	8x10	80	D		1900		F		95			0
5 Canopy	12	14x21	294	C	7.38	1950		F	2,170	95	110		100
6 Crib - Wire	SV*	16x12	192	D		1950		A	200	95			200
7 Lean - To	7	39x32	1,248	C	4.80	1950		A	5,990	95	300		300
8 Pole Bldg	12	24x36	864	D	10.81	1963		A	9,340	85	1,400		1,400
9 Granary	10	10x14	140	D	6.16	1900		F	860	95	40		0
10 Lean - To	10	21x25	525	C	4.80	1977		A	2,520	80	500		500
11 Lean - To	8	24x43	1,032	C	4.80	1977		A	4,950	80	990		1,000

03-041000.0000	* Value Override Item	TOTAL	119,600
----------------	-----------------------	-------	---------

COMMENTS

Dwelling has an Economic Factor of 100% (Rollback Basis=\$140,750)

BUTLER TWP / COLDWATER SD

08-35-100-001

AGR DISTRICT: BUT37:2019:2024

Property Class: 111

Neighborhood  
008031-A275

Map: 18

Block:

Card: 05

Bk: Pg:

03-041000.0000

**LEGAL INFORMATION**

N END W SD NW

**QUALIFIED CREDITS:**

**HOMESTEAD, CAUV: 01563**

RTS: 002-06-35

Acres:20.0000

**LINN JERRY L**

LINN JERRY L

5004 ST RT 219

COLDWATER, OH 45828

	OWNERSHIP	ADDRESS	CITY	STATE	ZIP	DATE	AMOUNT	DEED:CONV#	JS	VALID
1	LINN JERRY L	5004 ST RT 219	COLDWATER	OH	45828	11/26/1985	0	: X : 0	<input type="checkbox"/>	<input type="checkbox"/>
2							0	0	<input type="checkbox"/>	<input type="checkbox"/>
3							0	0	<input type="checkbox"/>	<input type="checkbox"/>

X:  TTO LISTER: SS DATE: 02/07/2012 TIME: 12:00:00 AM  LETTER  LETTER REC'D GIS CODE

STREET/ROAD	TOPOGRAPHY	PU-UTILITIES-PR	NEIGHBORHOOD	INFLUENCE FACTORS	PROPERTY LOCATION
<input checked="" type="checkbox"/> PAVED	<input checked="" type="checkbox"/> LEVEL	<input type="checkbox"/> WATER <input type="checkbox"/>	<input type="checkbox"/> IMPROVING	<input type="checkbox"/> A. NO ROAD <input type="checkbox"/> F. RESTRICT	5004 ST RT 219, COLDWATER
<input type="checkbox"/> GRAVEL	<input type="checkbox"/> HIGH	<input type="checkbox"/> SEWER <input type="checkbox"/>	<input type="checkbox"/> STATIC	<input type="checkbox"/> B. TOPGRHY <input type="checkbox"/> G. WOOD LT	COMMENT
<input type="checkbox"/> DIRT	<input type="checkbox"/> LOW	<input type="checkbox"/> GAS <input type="checkbox"/>	<input type="checkbox"/> DECLINING	<input type="checkbox"/> C. Ex Front <input type="checkbox"/> H. VACANCY	
<input type="checkbox"/> SIDEWALKS	<input type="checkbox"/> ROLLING	<input type="checkbox"/> ELECTRIC <input type="checkbox"/>	<input type="checkbox"/> OLD	<input type="checkbox"/> D. QUANTITY <input type="checkbox"/> I. WATER FRONT	
<input type="checkbox"/> CURBS	<input type="checkbox"/> STANDARD	<input checked="" type="checkbox"/> STANDARD	<input type="checkbox"/> STANDARD	<input type="checkbox"/> E. SZ/SHAPE <input type="checkbox"/> J. OTHER/CDU	

**LAND COMPUTATIONS**

LAND TYPE	SIZE	M	RATE	C	INF	M	VALUE	C
Total Acres: 20.0000						TOTAL	229,340	78,650

**VALUATION SUMMARY**

VALUE YEAR							
REASON FOR CHANGE							
APPRaised	LAND						
VALUE	IMPR						
	TOTAL						
ASSESSED	LAND						
VALUE	IMPR						
	TOTAL						
POTENTIAL RECOUP	2022=2094.40, 2021=2106.05, 2020=2004.63: Total=6205.08						

