

BUTLER TWP / COLDWATER SD

08-26-400-006

Property Class: 510

Neighborhood

009035-R150

Map: 13

Block:

Card: 33

Bk: Pg:

03-020200.0000

GEIER KEVIN M & ELIZBETH S

GEIER KEVIN M & ELIZBETH S

5440 ST RTE 219

COLDWATER, OH 45828

LEGAL INFORMATION

PT SE SE

RTS: 002-06-26

Acres:0.4790

	OWNERSHIP	ADDRESS	CITY	STATE	ZIP	DATE	AMOUNT	DEED:CONV#	JS	VALID
1	GEIER KEVIN M & ELIZBETH S	5440 ST RTE 219	COLDWATER	OH	45828	09/24/2018	180,000	WDC : 732	<input type="checkbox"/>	<input checked="" type="checkbox"/>
2	SEITZ SHAUN S & ERIN K	5440 ST RTE 219	COLDWATER	OH	45828	05/19/2008	118,000	WDC : F : 321	<input type="checkbox"/>	<input type="checkbox"/>
3	SEITZ MARY ANN	5440 ST RT 219	COLDWATER	OH	45828	04/24/2000	0	: X : 0	<input type="checkbox"/>	<input type="checkbox"/>

X: TTO LISTER: JO DATE: 04/15/2005 TIME: 12:00:00 AM LETTER LETTER REC'D GIS CODE

STREET/ROAD	TOPOGRAPHY	PU-UTILITIES-PR	NEIGHBORHOOD	INFLUENCE FACTORS		PROPERTY LOCATION
<input checked="" type="checkbox"/> PAVED	<input checked="" type="checkbox"/> LEVEL	<input type="checkbox"/> WATER	<input checked="" type="checkbox"/> IMPROVING	<input type="checkbox"/> A. NO ROAD	<input type="checkbox"/> F. RESTRICT	5440 ST RT 219, COLDWATER
<input type="checkbox"/> GRAVEL	<input type="checkbox"/> HIGH	<input type="checkbox"/> SEWER	<input checked="" type="checkbox"/> STATIC	<input type="checkbox"/> B. TOPGRHY	<input type="checkbox"/> G. WOOD LT	COMMENT
<input type="checkbox"/> DIRT	<input type="checkbox"/> LOW	<input checked="" type="checkbox"/> GAS	<input type="checkbox"/> DECLINING	<input type="checkbox"/> C. Ex Front	<input type="checkbox"/> H. VACANCY	TY2022:Net Gen=\$1,860.80, Other
<input type="checkbox"/> SIDEWALKS	<input type="checkbox"/> ROLLING	<input checked="" type="checkbox"/> ELECTRIC	<input type="checkbox"/> OLD	<input type="checkbox"/> D. QUANTITY	<input type="checkbox"/> I. WATER FRONT	Assessment=\$0.00
<input type="checkbox"/> CURBS	<input type="checkbox"/> STANDARD	<input type="checkbox"/> STANDARD	<input type="checkbox"/> STANDARD	<input type="checkbox"/> E. SZ/SHAPE	<input type="checkbox"/> J. OTHER/CDU	DE22 ADD 1/2 BATH PER DATA MAILER

LAND COMPUTATIONS

LAND TYPE	SIZE	M	RATE	C	INF	M	VALUE	C
HS:Home Site <1 @ 32050*0.75	AC:0.479	24040				24,000	0	
					TOTAL	24,000	0	

VALUATION SUMMARY

VALUE YEAR	2023	2022	2020	2017
REASON FOR CHANGE	RAPP	MISC	RAPP	RAPP
APPRAISED VALUE	24,000	13,200	13,200	12,400
	IMPR	179,700	131,500	129,700
	TOTAL	203,700	144,700	142,900
ASSESSED VALUE	8,400	4,620	4,620	4,340
	IMPR	62,900	46,030	45,400
	TOTAL	71,300	50,650	50,020

OCCUPANCY	EXTERIOR	FLOOR	AREA	CONST	VALUE
<input checked="" type="checkbox"/> SF <input type="checkbox"/> DU <input type="checkbox"/> TR	<input type="checkbox"/> WOOD	1	1064	FR	165,960
<input type="checkbox"/> CONVERSION	<input type="checkbox"/> STUCCO	.25	266	FR	37,850
BUILDING TYPE	<input checked="" type="checkbox"/> ALM/VYNL				
<input type="checkbox"/> MOBILE HOME	<input type="checkbox"/> CONC BLK				
<input type="checkbox"/> BI/TR LEVEL	<input type="checkbox"/> METAL				
<input type="checkbox"/> MOD/MAN	<input type="checkbox"/> BRICK				
<input type="checkbox"/>	<input type="checkbox"/> STONE				

ROOFING	ROOF TYPE
<input type="checkbox"/> METAL	<input checked="" type="checkbox"/> GABLE
<input type="checkbox"/> SLT/TLE	<input type="checkbox"/> HIP
<input checked="" type="checkbox"/> SHINGLES	<input type="checkbox"/> GAMBREL
<input type="checkbox"/> SHAKES	<input type="checkbox"/> MANSARD
<input type="checkbox"/> COMPOSITE	<input type="checkbox"/> FLAT

FLOORS	B	1	2	3	U
CONCRETE	<input checked="" type="checkbox"/>	<input type="checkbox"/>	<input type="checkbox"/>	<input type="checkbox"/>	<input type="checkbox"/>
WOOD	<input type="checkbox"/>	<input type="checkbox"/>	<input type="checkbox"/>	<input type="checkbox"/>	<input type="checkbox"/>
TILE/COMPO	<input type="checkbox"/>	<input checked="" type="checkbox"/>	<input type="checkbox"/>	<input type="checkbox"/>	<input type="checkbox"/>
CARPET	<input type="checkbox"/>	<input type="checkbox"/>	<input checked="" type="checkbox"/>	<input type="checkbox"/>	<input type="checkbox"/>
INT. FINISH	B	1	2	3	U
PLASTER/DW	<input type="checkbox"/>	<input checked="" type="checkbox"/>	<input checked="" type="checkbox"/>	<input type="checkbox"/>	<input type="checkbox"/>
PANELING	<input type="checkbox"/>	<input type="checkbox"/>	<input type="checkbox"/>	<input type="checkbox"/>	<input type="checkbox"/>
UNFINISHED	<input type="checkbox"/>	<input type="checkbox"/>	<input type="checkbox"/>	<input type="checkbox"/>	<input type="checkbox"/>
ACCOMMODATIONS					
# OF ROOMS		5	2		
BEDROOMS		2	2		
FIREPLACES					
HEAT & AC	B	1	2	3	U
NO HEAT	<input type="checkbox"/>	<input type="checkbox"/>	<input type="checkbox"/>	<input type="checkbox"/>	<input type="checkbox"/>
CTRL HEAT	<input checked="" type="checkbox"/>	<input checked="" type="checkbox"/>	<input checked="" type="checkbox"/>	<input type="checkbox"/>	<input type="checkbox"/>
HW/STEAM	<input type="checkbox"/>	<input type="checkbox"/>	<input type="checkbox"/>	<input type="checkbox"/>	<input type="checkbox"/>
ELECTRIC	<input type="checkbox"/>	<input type="checkbox"/>	<input type="checkbox"/>	<input type="checkbox"/>	<input type="checkbox"/>
HEAT PUMP	<input type="checkbox"/>	<input type="checkbox"/>	<input type="checkbox"/>	<input type="checkbox"/>	<input type="checkbox"/>
FLR/WALL	<input type="checkbox"/>	<input type="checkbox"/>	<input type="checkbox"/>	<input type="checkbox"/>	<input type="checkbox"/>
STVE/SPCE	<input type="checkbox"/>	<input type="checkbox"/>	<input type="checkbox"/>	<input type="checkbox"/>	<input type="checkbox"/>
GEOHERMAL	<input type="checkbox"/>	<input type="checkbox"/>	<input type="checkbox"/>	<input type="checkbox"/>	<input type="checkbox"/>
OUTSIDE	<input type="checkbox"/>	<input type="checkbox"/>	<input type="checkbox"/>	<input type="checkbox"/>	<input type="checkbox"/>
CTRL A/C	<input checked="" type="checkbox"/>	<input checked="" type="checkbox"/>	<input checked="" type="checkbox"/>	<input type="checkbox"/>	<input type="checkbox"/>
PLUMBING	BASE	<input checked="" type="checkbox"/>			
X FULL BATH		1			
X HALF BATH		1			
X FIXTURES					

BSMT	1064		15,220
SUBTOTAL			219,030
MULTI-FAMILY #	0		0
BUILDING TYPE	100%		0
BSMT FINISH	532 S.F.		7,610
FIREPLACE #	0		0
HEATING	0 S.F.		0
AIR COND	1,862 S.F.		3,080
PLUMBING #	5		6,050
GARAGES & CARPORTS			15,400
EXTRA FEATURES			6,500
SUBTOTAL			257,670
GRADE FACTOR			100 %
UNADJUSTED VALUE			257,670
FACTOR			100 %

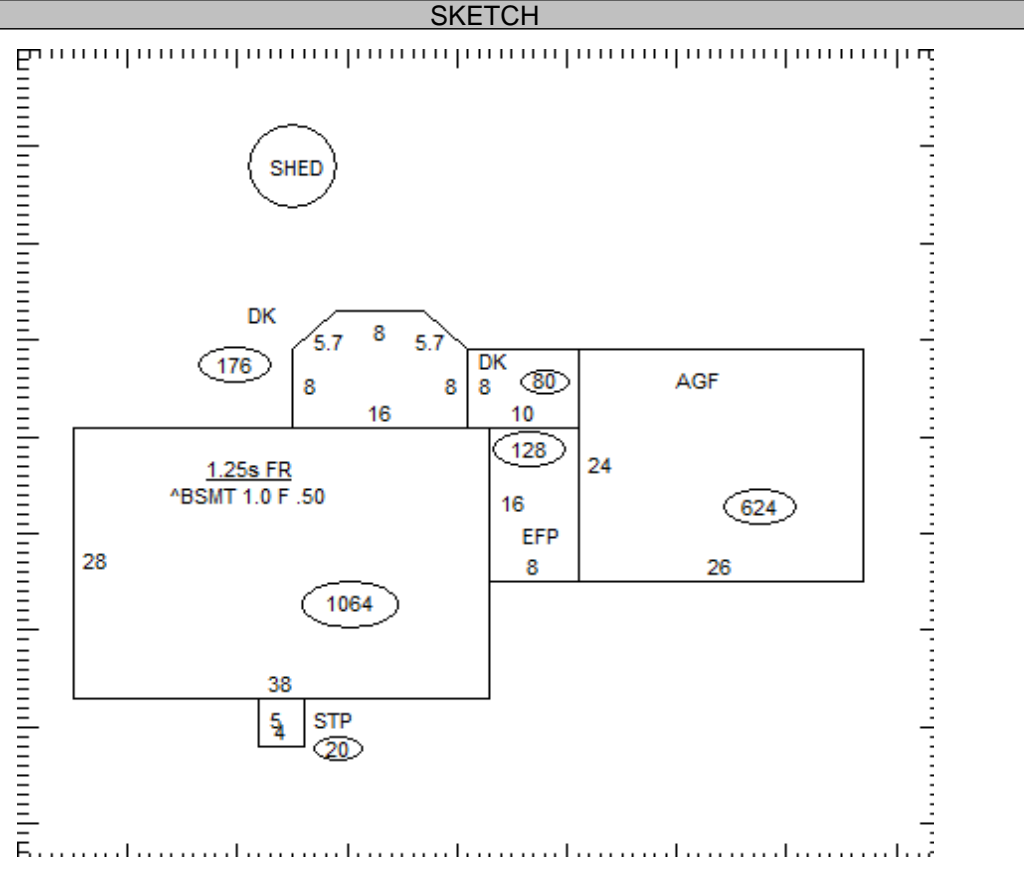

OCCUPANCY	ST.HT	SIZE	AREA	GRADE	PRICE	AGE	REMD	CND	UNADJ VAL	PHYS	PHYS VAL	FUNC	TRUE VAL
DWELLING	1.25	SK	1,330	C		1954		A	257,670	42	149,450		179,300
1 Shed	10	0x0	448	C	7.70	1954		A	3,450	90	350		400
2													
3													
4													
5													
6													
7													
8													
9													
10													
11													

03-020200.0000	TOTAL	179,700
----------------	--------------	---------

COMMENTS

Dwelling has an Economic Factor of 120% (Rollback Basis=\$203,300)