



03-011000.0000

BUTLER TWP / COLDWATER SD

08-20-300-001

Property Class: 510

Neighborhood

009035-R150

Map: 08

Block:

Card: 11

Bk: Pg:

LEGAL INFORMATION

NW COR SW SEC

RTS: 002-06-20

Acres:1.5610

MIDWEST RENTAL PROPERTIES LLC

MIDWEST RENTAL PROPERTIES LLC

314 S MAIN ST

CELINA, OH 45822

	OWNERSHIP	ADDRESS	CITY	STATE	ZIP	DATE	AMOUNT	DEED:CONV#	JS	VALID
1	MIDWEST RENTAL	314 S MAIN ST	CELINA	OH	45822	03/02/2016	183,500	WDC : 116	<input type="checkbox"/>	<input checked="" type="checkbox"/>
2	NOW PATRICIA A	5240 GAUSE RD	COLDWATER	OH	45828	03/20/2008	0	QCE : X : 0	<input type="checkbox"/>	<input type="checkbox"/>
3	NOW DALE E & PATRICIA A	5240 GAUSE RD	COLDWATER	OH	45828		0	: 0	<input type="checkbox"/>	<input type="checkbox"/>

X: TTO LISTER: JO DATE: 03/30/2005 TIME: 12:00:00 AM LETTER LETTER REC'D GIS CODE

STREET/ROAD TOPOGRAPHY PU-UTILITIES-PR NEIGHBORHOOD INFLUENCE FACTORS PROPERTY LOCATION

PAVED LEVEL WATER IMPROVING A. NO ROAD F. RESTRICT 5240 GAUSE RD, COLDWATER
 GRAVEL HIGH SEWER STATIC B. TOPGRHY G. WOOD LT COMMENT
 DIRT LOW GAS DECLINING C. Ex Front H. VACANCY TY2022:Net Gen=\$2,883.00, Other
 SIDEWALKS ROLLING ELECTRIC OLD D. QUANTITY I. WATER FRONT Assessment=\$2.64
 CURBS STANDARD STANDARD STANDARD E. SZ/SHAPE J. OTHER/CDU DE17 DESKTOP RWV CHG: ADD + STRY
DE17 RMV OWN OCC DUE TO OWNERSHIP

LAND COMPUTATIONS

LAND TYPE	SIZE	M	RATE	C	INF	M	VALUE	C
HS:Home Site	AC:1	32050				32,100	0	
SM:Small Acreage	AC:0.561	8500				4,800	0	
Total Acres: 1.5610					TOTAL	36,900	0	

VALUATION SUMMARY

VALUE YEAR	2023	2020	2017	2017				
REASON FOR CHANGE	RAPP	RAPP	RAPP	MISC				
APPRAISED <u>LAND</u>	36,900	21,900	20,400	21,800				
VALUE <u>IMPR</u>	261,800	196,900	174,100	144,800				
<u>TOTAL</u>	298,700	218,800	194,500	166,600				
ASSESSED <u>LAND</u>	12,920	7,670	7,140	7,630				
VALUE <u>IMPR</u>	91,630	68,920	60,940	50,680				
<u>TOTAL</u>	104,550	76,590	68,080	58,310				

OCCUPANCY	EXTERIOR	FLOOR	AREA	CONST	VALUE
<input checked="" type="checkbox"/> SF <input type="checkbox"/> DU <input type="checkbox"/> TR	<input type="checkbox"/> WOOD	1	1880	FR	227,200
<input type="checkbox"/> CONVERSION	<input type="checkbox"/> STUCCO	+	0	FR	20,440
BUILDING TYPE	<input checked="" type="checkbox"/> ALM/VYNL				
<input type="checkbox"/> MOBILE HOME	<input type="checkbox"/> CONC BLK				
<input type="checkbox"/> BI/TR LEVEL	<input type="checkbox"/> METAL				
<input type="checkbox"/> MOD/MAN	<input type="checkbox"/> BRICK				
<input type="checkbox"/>	<input type="checkbox"/> STONE				

ROOFING	ROOF TYPE
<input type="checkbox"/> METAL	<input checked="" type="checkbox"/> GABLE
<input type="checkbox"/> SLT/TLE	<input type="checkbox"/> HIP
<input checked="" type="checkbox"/> SHINGLES	<input type="checkbox"/> GAMBREL
<input type="checkbox"/> SHAKES	<input type="checkbox"/> MANSARD
<input type="checkbox"/> COMPOSITE	<input type="checkbox"/> FLAT

FLOORS	B	1	2	3	U
CONCRETE	<input checked="" type="checkbox"/>	<input type="checkbox"/>	<input type="checkbox"/>	<input type="checkbox"/>	<input type="checkbox"/>
WOOD	<input type="checkbox"/>	<input checked="" type="checkbox"/>	<input type="checkbox"/>	<input type="checkbox"/>	<input type="checkbox"/>
TILE/COMPO	<input type="checkbox"/>	<input type="checkbox"/>	<input type="checkbox"/>	<input type="checkbox"/>	<input type="checkbox"/>
CARPET	<input type="checkbox"/>	<input type="checkbox"/>	<input type="checkbox"/>	<input type="checkbox"/>	<input type="checkbox"/>
INT. FINISH	B	1	2	3	U
PLASTER/DW	<input type="checkbox"/>	<input checked="" type="checkbox"/>	<input type="checkbox"/>	<input type="checkbox"/>	<input type="checkbox"/>
PANELING	<input type="checkbox"/>	<input type="checkbox"/>	<input type="checkbox"/>	<input type="checkbox"/>	<input type="checkbox"/>
UNFINISHED	<input checked="" type="checkbox"/>	<input type="checkbox"/>	<input type="checkbox"/>	<input type="checkbox"/>	<input type="checkbox"/>
ACCOMMODATIONS					
# OF ROOMS		7			
BEDROOMS		3			
FIREPLACES					
HEAT & AC	B	1	2	3	U
NO HEAT	<input type="checkbox"/>	<input type="checkbox"/>	<input type="checkbox"/>	<input type="checkbox"/>	<input type="checkbox"/>
CTRL HEAT	<input type="checkbox"/>	<input checked="" type="checkbox"/>	<input type="checkbox"/>	<input type="checkbox"/>	<input type="checkbox"/>
HW/STEAM	<input type="checkbox"/>	<input type="checkbox"/>	<input type="checkbox"/>	<input type="checkbox"/>	<input type="checkbox"/>
ELECTRIC	<input type="checkbox"/>	<input type="checkbox"/>	<input type="checkbox"/>	<input type="checkbox"/>	<input type="checkbox"/>
HEAT PUMP	<input type="checkbox"/>	<input type="checkbox"/>	<input type="checkbox"/>	<input type="checkbox"/>	<input type="checkbox"/>
FLR/WALL	<input type="checkbox"/>	<input type="checkbox"/>	<input type="checkbox"/>	<input type="checkbox"/>	<input type="checkbox"/>
STVE/SPCE	<input type="checkbox"/>	<input type="checkbox"/>	<input type="checkbox"/>	<input type="checkbox"/>	<input type="checkbox"/>
GEOHERMAL	<input type="checkbox"/>	<input type="checkbox"/>	<input type="checkbox"/>	<input type="checkbox"/>	<input type="checkbox"/>
OUTSIDE	<input type="checkbox"/>	<input type="checkbox"/>	<input type="checkbox"/>	<input type="checkbox"/>	<input type="checkbox"/>
CTRL A/C	<input type="checkbox"/>	<input checked="" type="checkbox"/>	<input type="checkbox"/>	<input type="checkbox"/>	<input type="checkbox"/>
PLUMBING	BASE	<input checked="" type="checkbox"/>			
X FULL BATH		1			
X HALF BATH					
X FIXTURES					

BSMT	800		11,440
SUBTOTAL			259,080
MULTI-FAMILY #	0		0
BUILDING TYPE	100%		0
BSMT FINISH	0 S.F.		0
FIREPLACE #	0		0
HEATING	0 S.F.		0
AIR COND	1,880 S.F.		3,100
PLUMBING #	3		3,630
GARAGES & CARPORTS			14,200
EXTRA FEATURES			7,400
SUBTOTAL			287,410
GRADE FACTOR			100 %
UNADJUSTED VALUE			287,410
FACTOR			100 %

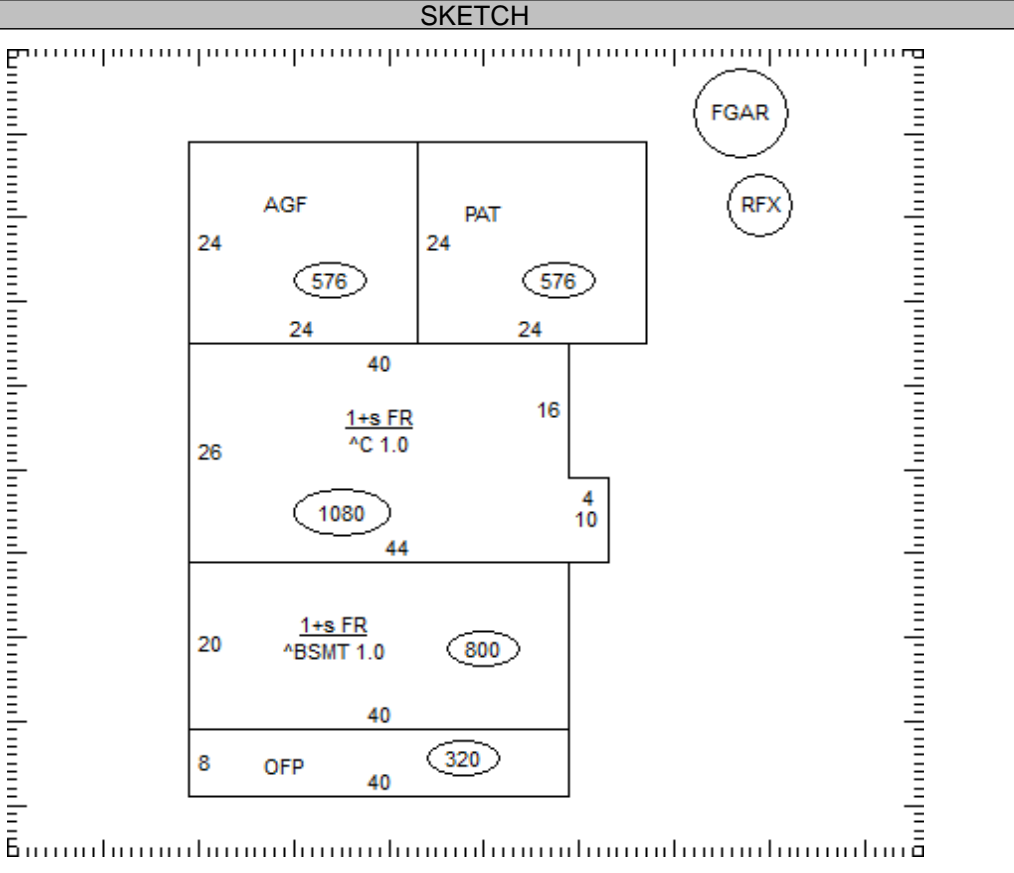

OCCUPANCY	ST.HT	SIZE	AREA	GRADE	PRICE	AGE	REMD	CND	UNADJ VAL	PHYS	PHYS VAL	FUNC	TRUE VAL
DWELLING	1	SK	1,880	C		1990		A	287,410	26	212,680		255,200
1 Gar - Frame	8	28x38	1,064	C	23.70	1978		A	25,220	77	5,800		5,800
2 Rfx	8	10x38	380	C	8.91	1978		A	3,390	77	780		800
3													
4													
5													
6													
7													
8													
9													
10													
11													

03-011000.0000

TOTAL 261,800

COMMENTS

Dwelling has an Economic Factor of 120%