

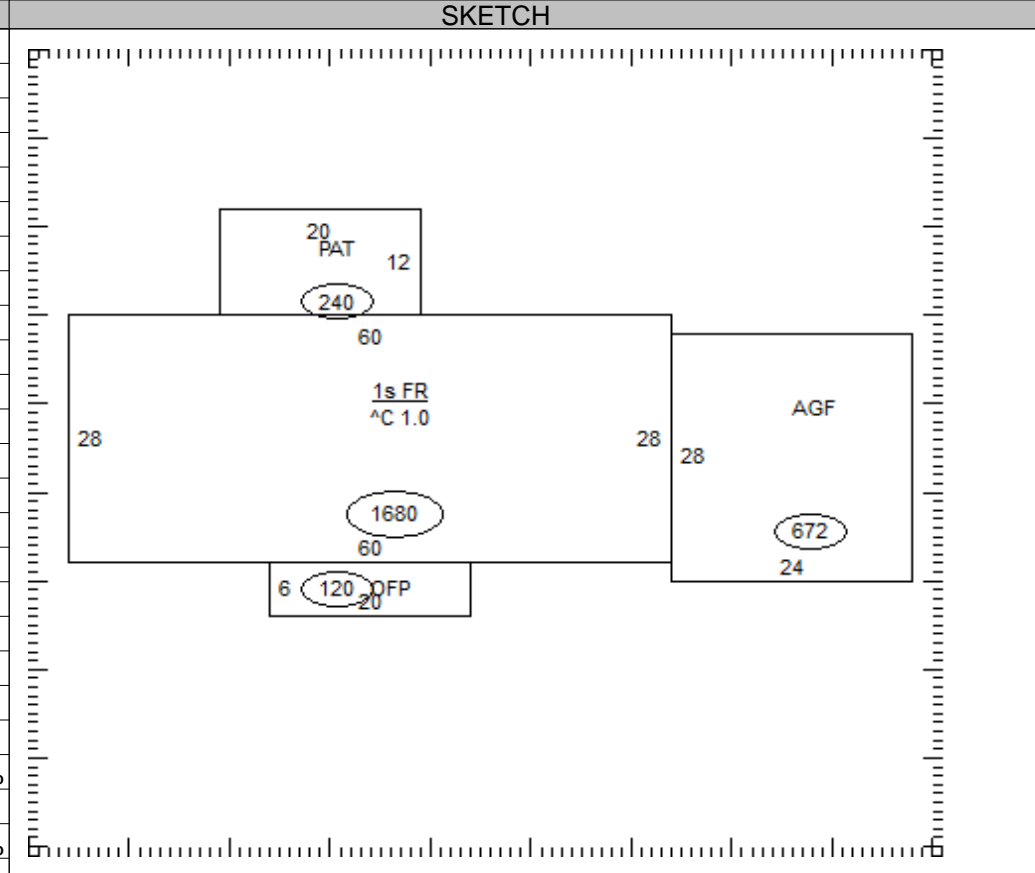

**OCCUPANCY**  
 SF  DU  TR  
 CONVERSION  
**BUILDING TYPE**  
 MOBILE HOME  
 BI/TR LEVEL  
 MOD/MAN

FLOOR	AREA	CONST	VALUE
1	1680	FR	214,300



**ROOFING**  
 METAL  
 SLT/TLE  
 SHINGLES  
 SHAKES  
 COMPOSITE

**ROOF TYPE**  
 GABLE  
 HIP  
 GAMBREL  
 MANSARD  
 FLAT

SUBTOTAL			214,300
MULTI-FAMILY #	0		0
BUILDING TYPE	100%		0
BSMT FINISH	0 S.F.		0
FIREPLACE #	0		0
HEATING	0 S.F.		0
AIR COND	1,680 S.F.		2,770
PLUMBING #	3		3,630
GARAGES & CARPORTS			16,600
EXTRA FEATURES			2,900
SUBTOTAL			240,200
GRADE FACTOR			100 %
UNADJUSTED VALUE			240,200
FACTOR			100 %

**FLOORS** B 1 2 3 U  
 CONCRETE       
 WOOD       
 TILE/COMPO       
 CARPET

SUBTOTAL			240,200
GRADE FACTOR			100 %
UNADJUSTED VALUE			240,200
FACTOR			100 %

**INT. FINISH** B 1 2 3 U  
 PLASTER/DW       
 PANELING       
 UNFINISHED

SUBTOTAL			240,200
GRADE FACTOR			100 %
UNADJUSTED VALUE			240,200
FACTOR			100 %

**ACCOMMODATIONS**  
 # OF ROOMS 5  
 BEDROOMS 3  
 FIREPLACES

SUBTOTAL			240,200
GRADE FACTOR			100 %
UNADJUSTED VALUE			240,200
FACTOR			100 %

**HEAT & AC** B 1 2 3 U  
 NO HEAT       
 CTRL HEAT       
 HW/STEAM       
 ELECTRIC       
 HEAT PUMP       
 FLR/WALL       
 STVE/SPCE       
 GEOTHERMAL       
 OUTSIDE       
 CTRL A/C

OCCUPANCY	ST.HT	SIZE	AREA	GRADE	PRICE	AGE	REMD	CND	UNADJ VAL	PHYS	PHYS VAL	FUNC	TRUE VAL
DWELLING	1	SK	1,680	C		2023		G	240,200	1	237,800	INC100	
1													
2													
3													
4													
5													
6													
7													
8													
9													
10													
11													

**PLUMBING** BASE   
 X FULL BATH 1  
 X HALF BATH  
 X FIXTURES

02-010500.0100

TOTAL 0

COMMENTS