

BLACKCREEK TWP / PARKWAY SD

01-26-400-002

Property Class: 111

Neighborhood

009011-A100

Map: 07

Block: 01

Card: 10

Bk: Pg:

01-034100.0000

TAYLOR DAVID E & KATHY J

TAYLOR DAVID E & KATHY J

PO BOX 204

ROCKFORD, OH 45882

LEGAL INFORMATION

S 1/2 SE

RTS: 001-04-26

Acres:15.9730

QUALIFIED CREDITS:

HOMESTEAD, CAUV: 06920:

2022

	OWNERSHIP	ADDRESS	CITY	STATE	ZIP	DATE	AMOUNT	DEED:CONV#	JS	VALID
1	TAYLOR DAVID E & KATHY J	PO BOX 204	ROCKFORD	OH	45882	12/16/2021	0	QCE : X : 0	<input type="checkbox"/>	<input type="checkbox"/>
2	TAYLOR KATHY J	PO BOX 235	ROCKFORD	OH	45882	10/12/2021	350,000	WDC : 878	<input type="checkbox"/>	<input checked="" type="checkbox"/>
3	J R FARMS INC	PO BOX 531	ROCKFORD	OH	45882	01/01/1900	0	: 0	<input type="checkbox"/>	<input type="checkbox"/>

X:	<input type="checkbox"/> TTO	LISTER:	DATE: 11/22/2010	TIME: 12:00:00 AM	<input type="checkbox"/> LETTER	<input type="checkbox"/> LETTER REC'D	GIS CODE
----	------------------------------	---------	------------------	-------------------	---------------------------------	---------------------------------------	----------

STREET/ROAD	TOPOGRAPHY	PU-UTILITIES-PR	NEIGHBORHOOD	INFLUENCE FACTORS	PROPERTY LOCATION
<input checked="" type="checkbox"/> PAVED	<input checked="" type="checkbox"/> LEVEL	<input type="checkbox"/> WATER	<input type="checkbox"/> IMPROVING	<input type="checkbox"/> A. NO ROAD	2429 ST RTE 707, ROCKFORD
<input type="checkbox"/> GRAVEL	<input type="checkbox"/> HIGH	<input type="checkbox"/> SEWER	<input type="checkbox"/> STATIC	<input type="checkbox"/> F. RESTRICT	COMMENT TY2022:Net Gen=\$1,994.92, Other Assessment=\$17.06 DE11 CORRECT EXTERIOR DE15 RMV GB VALUE PER ODT DE17 DESKTOP RVW CHG: COR PB MSMNT DE22 APPLY HS & OWN OCC
<input type="checkbox"/> DIRT	<input type="checkbox"/> LOW	<input type="checkbox"/> GAS	<input type="checkbox"/> DECLINING	<input type="checkbox"/> B. TOPGRHY	
<input type="checkbox"/> SIDEWALKS	<input type="checkbox"/> ROLLING	<input type="checkbox"/> ELECTRIC	<input type="checkbox"/> OLD	<input type="checkbox"/> C. Ex Front	
<input type="checkbox"/> CURBS	<input type="checkbox"/> STANDARD	<input checked="" type="checkbox"/> STANDARD	<input type="checkbox"/> STANDARD	<input type="checkbox"/> D. QUANTITY	
				<input type="checkbox"/> E. SZ/SHAPE	
				<input type="checkbox"/> G. WOOD LT	
				<input type="checkbox"/> H. VACANCY	
				<input type="checkbox"/> I. WATER FRONT	
				<input type="checkbox"/> J. OTHER/CDU	

LAND COMPUTATIONS						
LAND TYPE	SIZE	M	RATE	C	INF	M VALUE C
CR:Crop Land TOTAL	A 13.9710	11,750	2,920			171,110 46,910
0087	A 10.8320	12,450	3,560			134,860 38,560
0024	A .0140	11,250	2,540			160 40
0023	A 3.1250	11,550	2,660			36,090 8,310
HS:Home Site	A 1.0000	17,490	17,490			17,490 17,490
RD:Road	A 1.0020	0	0			0 0
Total Acres: 15.9730					TOTAL	188,600 64,400

VALUATION SUMMARY								
VALUE YEAR	2023	2023	2022	2022	2020	2020	2017	2017
REASON FOR CHANGE	CAUV	RAPP	CAUV	MISC	CAUV	RAPP	CAUV	RAPP
APPRAISED	64,400	188,600	42,520	146,780	153,360	725,040	210,600	656,790
VALUE	IMPR	210,300	210,300	121,600	121,600	121,600	115,900	115,900
	TOTAL	274,700	398,900	164,120	268,380	274,960	326,500	772,690
ASSESSED	LAND	22,540	66,010	14,880	51,370	53,680	253,760	73,710
VALUE	IMPR	73,610	73,610	42,560	42,560	42,560	40,570	40,570
	TOTAL	96,150	139,620	57,440	93,930	96,240	114,280	270,450
POTENTIAL RECOUP	2022=1523.86, 2021=1514.51, 2020=1536.45: Total=4574.82							

OCCUPANCY		EXTERIOR		FLOOR	AREA	CONST	VALUE
<input checked="" type="checkbox"/> SF <input type="checkbox"/> DU <input type="checkbox"/> TR	<input checked="" type="checkbox"/> WOOD	1	1769	BRK			234,750
<input type="checkbox"/> CONVERSION	<input type="checkbox"/> STUCCO						
BUILDING TYPE							
<input type="checkbox"/> MOBILE HOME	<input type="checkbox"/> ALM/VYNL						
<input type="checkbox"/> BI/TR LEVEL	<input type="checkbox"/> CONC BLK						
<input type="checkbox"/> MOD/MAN	<input type="checkbox"/> METAL						
<input type="checkbox"/>	<input checked="" type="checkbox"/> BRICK						
	<input type="checkbox"/> STONE						
ROOFING		ROOF TYPE					
<input type="checkbox"/> METAL	<input checked="" type="checkbox"/> GABLE						
<input type="checkbox"/> SLT/TLE	<input type="checkbox"/> HIP						
<input checked="" type="checkbox"/> SHINGLES	<input type="checkbox"/> GAMBREL						
<input type="checkbox"/> SHAKES	<input type="checkbox"/> MANSARD						
<input type="checkbox"/> COMPOSITE	<input type="checkbox"/> FLAT						
BSMT		1769					25,300
SUBTOTAL							260,050
MULTI-FAMILY #		0					0
BUILDING TYPE		100%					0
CONCRETE		<input type="checkbox"/>	<input type="checkbox"/>	<input type="checkbox"/>	<input type="checkbox"/>	<input type="checkbox"/>	
WOOD		<input type="checkbox"/>	<input type="checkbox"/>	<input type="checkbox"/>	<input type="checkbox"/>	<input type="checkbox"/>	
TILE/COMPO		<input type="checkbox"/>	<input checked="" type="checkbox"/>	<input type="checkbox"/>	<input type="checkbox"/>	<input type="checkbox"/>	
CARPET		<input type="checkbox"/>	<input checked="" type="checkbox"/>	<input type="checkbox"/>	<input type="checkbox"/>	<input type="checkbox"/>	
INT. FINISH		B	1	2	3	U	
PLASTER/DW		<input type="checkbox"/>	<input checked="" type="checkbox"/>	<input type="checkbox"/>	<input type="checkbox"/>	<input type="checkbox"/>	
PANELING		<input checked="" type="checkbox"/>	<input checked="" type="checkbox"/>	<input type="checkbox"/>	<input type="checkbox"/>	<input type="checkbox"/>	
UNFINISHED		<input checked="" type="checkbox"/>	<input type="checkbox"/>	<input type="checkbox"/>	<input type="checkbox"/>	<input type="checkbox"/>	
ACCOMMODATIONS							
# OF ROOMS		3					
BEDROOMS							
FIREPLACES							
HEAT & AC		B	1	2	3	U	
NO HEAT		<input type="checkbox"/>	<input type="checkbox"/>	<input type="checkbox"/>	<input type="checkbox"/>	<input type="checkbox"/>	
CTRL HEAT		<input checked="" type="checkbox"/>	<input checked="" type="checkbox"/>	<input type="checkbox"/>	<input type="checkbox"/>	<input type="checkbox"/>	
HW/STEAM		<input type="checkbox"/>	<input type="checkbox"/>	<input type="checkbox"/>	<input type="checkbox"/>	<input type="checkbox"/>	
ELECTRIC		<input type="checkbox"/>	<input type="checkbox"/>	<input type="checkbox"/>	<input type="checkbox"/>	<input type="checkbox"/>	
HEAT PUMP		<input type="checkbox"/>	<input type="checkbox"/>	<input type="checkbox"/>	<input type="checkbox"/>	<input type="checkbox"/>	
FLR/WALL		<input type="checkbox"/>	<input type="checkbox"/>	<input type="checkbox"/>	<input type="checkbox"/>	<input type="checkbox"/>	
STVE/SPCE		<input type="checkbox"/>	<input type="checkbox"/>	<input type="checkbox"/>	<input type="checkbox"/>	<input type="checkbox"/>	
GEOTHERMAL		<input type="checkbox"/>	<input type="checkbox"/>	<input type="checkbox"/>	<input type="checkbox"/>	<input type="checkbox"/>	
OUTSIDE		<input type="checkbox"/>	<input type="checkbox"/>	<input type="checkbox"/>	<input type="checkbox"/>	<input type="checkbox"/>	
CTRL A/C		<input type="checkbox"/>	<input checked="" type="checkbox"/>	<input type="checkbox"/>	<input type="checkbox"/>	<input type="checkbox"/>	
PLUMBING			BASE		<input checked="" type="checkbox"/>		
X FULL BATH							
X HALF BATH		1					
X FIXTURES		1					

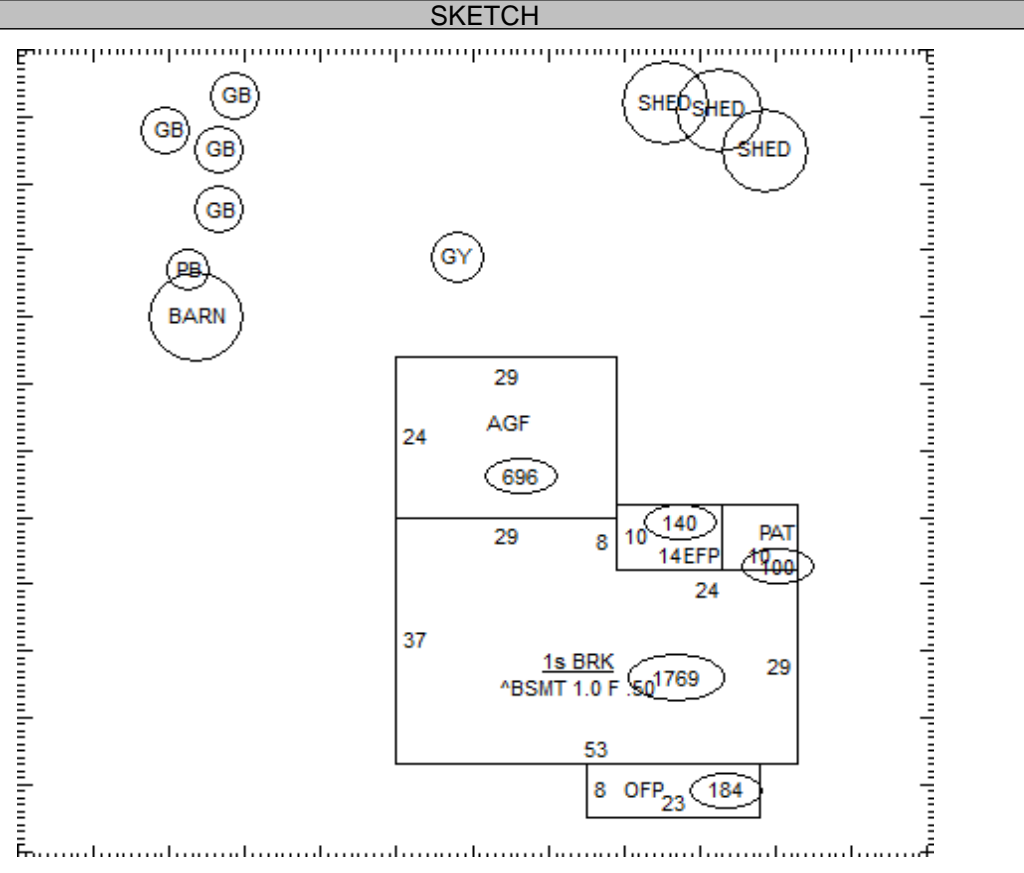

OCCUPANCY	ST.HT	SIZE	AREA	GRADE	PRICE	AGE	REMD	CND	UNADJ VAL	PHYS	PHYS VAL	FUNC	TRUE VAL
DWELLING	1	SK	1,769	C+		1964	1989	A	319,140	30	223,400		201,100
1 Barn	14	35x45	1,575	C	12.00	1900		A	18,900	95	950	DFLT50	500
2 Granary	12	25x40	1,000	C	7.70	1965		A	7,700	85	1,160	DFLT50	600
3 Pole Bldg	14	40x86	3,440	C	11.76	1975		A	40,450	80	8,090		8,100
4 Grain Bin	18	18x27	486	C		1977		A		80			0
5 Grain Bin	18	18x21	378	C		1978		A		77			0
6 Grain Bin	18	18x18	324	C		1979		A		77			0
7 Grain Bin	18	18x30	540	C		1980		A		77			0
8 Shed		6x8	48	C		1960		P		95			0
9 Shed		6x8	48	C		1960		P		95			0
10 Shed		8x10	80	C		1970		P		90			0
11													

01-034100.0000

TOTAL 210,300

COMMENTS

>>OB Features: 1.3 <Add 1/4 Concrete Floor>
 Dwelling has an Economic Factor of 90% (Rollback Basis=\$218,590)

BLACKCREEK TWP / PARKWAY SD

01-26-400-002

Property Class: 111

Neighborhood

009011-A100

Map: 07

Block: 01

Card: 10

Bk: Pg:

01-034100.0000

TAYLOR DAVID E & KATHY J

TAYLOR DAVID E & KATHY J

PO BOX 204

ROCKFORD, OH 45882

LEGAL INFORMATION

S 1/2 SE

RTS: 001-04-26

Acres:15.9730

QUALIFIED CREDITS:

HOMESTEAD, CAUV: 06920:

2022

	OWNERSHIP	ADDRESS	CITY	STATE	ZIP	DATE	AMOUNT	DEED:CONV#	JS	VALID
1	TAYLOR DAVID E & KATHY J	PO BOX 204	ROCKFORD	OH	45882	12/16/2021	0	QCE : X : 0	<input type="checkbox"/>	<input type="checkbox"/>
2	TAYLOR KATHY J	PO BOX 235	ROCKFORD	OH	45882	10/12/2021	350,000	WDC : 878	<input type="checkbox"/>	<input checked="" type="checkbox"/>
3	J R FARMS INC	PO BOX 531	ROCKFORD	OH	45882	01/01/1900	0	: 0	<input type="checkbox"/>	<input type="checkbox"/>

X: TTO LISTER: DATE: 11/22/2010 TIME: 12:00:00 AM LETTER LETTER REC'D GIS CODE

STREET/ROAD TOPOGRAPHY PU-UTILITIES-PR NEIGHBORHOOD INFLUENCE FACTORS PROPERTY LOCATION

<input checked="" type="checkbox"/> PAVED	<input checked="" type="checkbox"/> LEVEL	<input type="checkbox"/> WATER	<input type="checkbox"/> IMPROVING	<input type="checkbox"/> A. NO ROAD	<input type="checkbox"/> F. RESTRICT	2429 ST RTE 707, ROCKFORD COMMENT
<input type="checkbox"/> GRAVEL	<input type="checkbox"/> HIGH	<input type="checkbox"/> SEWER	<input type="checkbox"/> STATIC	<input type="checkbox"/> B. TOPGRHY	<input type="checkbox"/> G. WOOD LT	
<input type="checkbox"/> DIRT	<input type="checkbox"/> LOW	<input type="checkbox"/> GAS	<input type="checkbox"/> DECLINING	<input type="checkbox"/> C. Ex Front	<input type="checkbox"/> H. VACANCY	
<input type="checkbox"/> SIDEWALKS	<input type="checkbox"/> ROLLING	<input type="checkbox"/> ELECTRIC	<input type="checkbox"/> OLD	<input type="checkbox"/> D. QUANTITY	<input type="checkbox"/> I. WATER FRONT	
<input type="checkbox"/> CURBS	<input type="checkbox"/> STANDARD	<input checked="" type="checkbox"/> STANDARD	<input type="checkbox"/> STANDARD	<input type="checkbox"/> E. SZ/SHAPE	<input type="checkbox"/> J. OTHER/CDU	

LAND COMPUTATIONS

LAND TYPE	SIZE	M	RATE	C	INF	M	VALUE	C
Total Acres: 15.9730					TOTAL	188,600	64,400	

VALUATION SUMMARY

VALUE YEAR	2017	2017						
REASON FOR CHANGE	CAUV	MISC						
APPRAISED	LAND	282,160	590,940					
VALUE	IMPR	115,300	115,300					
	TOTAL	397,460	706,240					
ASSESSED	LAND	98,760	206,830					
VALUE	IMPR	40,360	40,360					
	TOTAL	139,120	247,190					
POTENTIAL RECOUP	2022=1523.86, 2021=1514.51, 2020=1536.45: Total=4574.82							

OCCUPANCY	EXTERIOR	FLOOR	AREA	CONST	VALUE
<input type="checkbox"/> SF <input type="checkbox"/> DU <input type="checkbox"/> TR	<input type="checkbox"/> WOOD				
<input type="checkbox"/> CONVERSION	<input type="checkbox"/> STUCCO				
BUILDING TYPE	<input type="checkbox"/> ALM/VYNL				
<input type="checkbox"/> MOBILE HOME	<input type="checkbox"/> CONC BLK				
<input type="checkbox"/> BI/TR LEVEL	<input type="checkbox"/> METAL				
<input type="checkbox"/> MOD/MAN	<input type="checkbox"/> BRICK				
<input type="checkbox"/> _____	<input type="checkbox"/> STONE				

ROOFING	ROOF TYPE
<input type="checkbox"/> METAL	<input type="checkbox"/> GABLE
<input type="checkbox"/> SLT/TLE	<input type="checkbox"/> HIP
<input type="checkbox"/> SHINGLES	<input type="checkbox"/> GAMBREL
<input type="checkbox"/> SHAKES	<input type="checkbox"/> MANSARD
<input type="checkbox"/> COMPOSITE	<input type="checkbox"/> FLAT

SUBTOTAL		0
MULTI-FAMILY #	0	0
BUILDING TYPE	000%	0
BSMT FINISH	0 S.F.	0
FIREPLACE #	0	0
HEATING	0 S.F.	0
AIR COND	0 S.F.	0
PLUMBING #	0	0
GARAGES & CARPORTS		0
EXTRA FEATURES		0
SUBTOTAL		0
GRADE FACTOR		%
UNADJUSTED VALUE		0
FACTOR		%

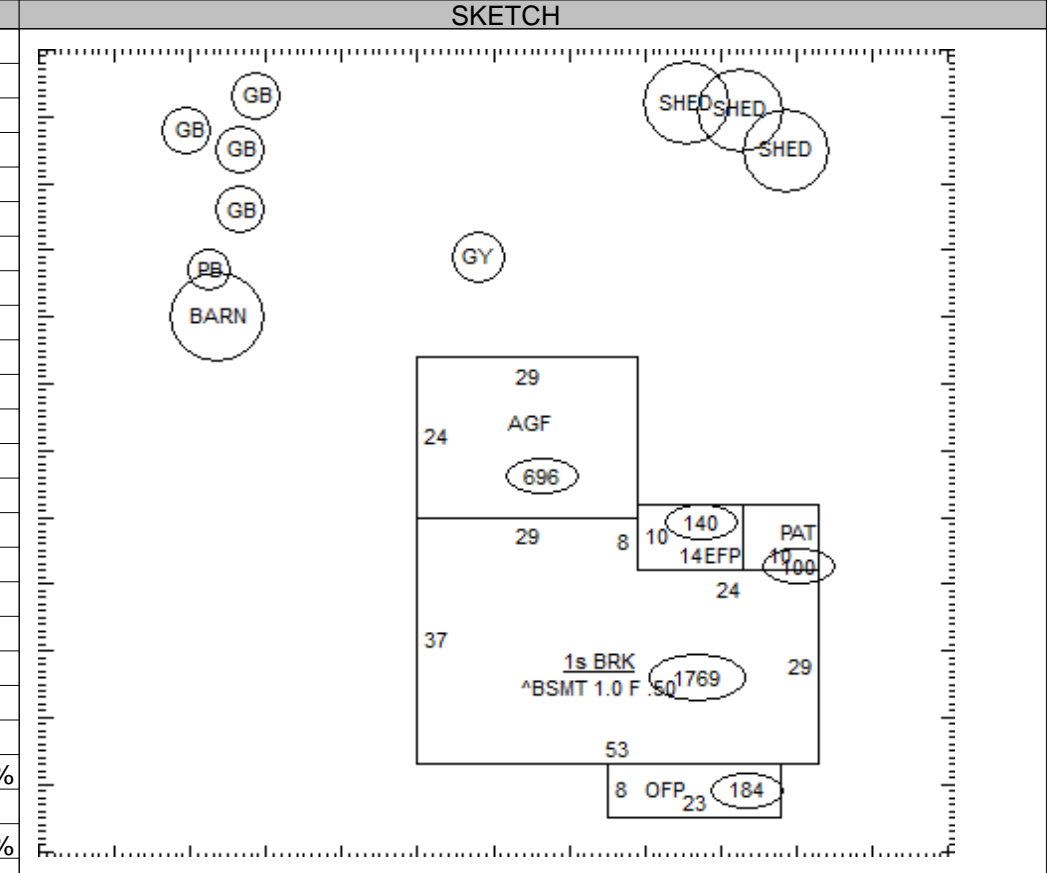

OCCUPANCY	ST.HT	SIZE	AREA	GRADE	PRICE	AGE	REMD	CND	UNADJ VAL	PHYS	PHYS VAL	FUNC	TRUE VAL
DWELLING		SK											
1													
2													
3													
4													
5													
6													
7													
8													
9													
10													
11													

01-034100.0000 TOTAL 0

COMMENTS