

OCCUPANCY	EXTERIOR	FLOOR	AREA	CONST	VALUE										
<input checked="" type="checkbox"/> SF <input type="checkbox"/> DU <input type="checkbox"/> TR	<input type="checkbox"/> WOOD	1	1008	FR	159,910										
<input type="checkbox"/> CONVERSION	<input type="checkbox"/> STUCCO	.5	240	FR	23,610										
BUILDING TYPE	<input checked="" type="checkbox"/> ALM/VYNL														
<input type="checkbox"/> MOBILE HOME	<input type="checkbox"/> CONC BLK														
<input type="checkbox"/> BI/TR LEVEL	<input type="checkbox"/> METAL														
<input type="checkbox"/> MOD/MAN	<input type="checkbox"/> BRICK														
<input type="checkbox"/>	<input type="checkbox"/> STONE														
ROOFING	ROOF TYPE														
<input type="checkbox"/> METAL	<input checked="" type="checkbox"/> GABLE														
<input type="checkbox"/> SLT/TLE	<input type="checkbox"/> HIP														
<input checked="" type="checkbox"/> SHINGLES	<input type="checkbox"/> GAMBREL														
<input type="checkbox"/> SHAKES	<input type="checkbox"/> MANSARD														
<input type="checkbox"/> COMPOSITE	<input type="checkbox"/> FLAT														
FLOORS	B 1 2 3 U	BSMT	408		5,830										
CONCRETE	<input checked="" type="checkbox"/> <input type="checkbox"/> <input type="checkbox"/> <input type="checkbox"/> <input type="checkbox"/>	SUBTOTAL			189,350										
WOOD	<input type="checkbox"/> <input type="checkbox"/> <input type="checkbox"/> <input type="checkbox"/> <input type="checkbox"/>	MULTI-FAMILY #	0		0										
TILE/COMPO	<input type="checkbox"/> <input checked="" type="checkbox"/> <input type="checkbox"/> <input type="checkbox"/> <input type="checkbox"/>	BUILDING TYPE	100%		0										
CARPET	<input type="checkbox"/> <input checked="" type="checkbox"/> <input checked="" type="checkbox"/> <input type="checkbox"/> <input type="checkbox"/>	BSMT FINISH	0 S.F.		0										
INT. FINISH	B 1 2 3 U	FIREPLACE #	0		0										
PLASTER/DW	<input type="checkbox"/> <input checked="" type="checkbox"/> <input checked="" type="checkbox"/> <input type="checkbox"/> <input type="checkbox"/>	HEATING	0 S.F.		0										
PANELING	<input type="checkbox"/> <input type="checkbox"/> <input type="checkbox"/> <input type="checkbox"/> <input type="checkbox"/>	AIR COND	0 S.F.		0										
UNFINISHED	<input checked="" type="checkbox"/> <input type="checkbox"/> <input type="checkbox"/> <input type="checkbox"/> <input type="checkbox"/>	PLUMBING #	0		0										
ACCOMMODATIONS		GARAGES & CARPORTS			0										
# OF ROOMS	4 4 2	EXTRA FEATURES			1,800										
BEDROOMS	1 1	SUBTOTAL			191,150										
FIREPLACES		GRADE FACTOR			100 %										
HEAT & AC	B 1 2 3 U	UNADJUSTED VALUE			191,150										
NO HEAT	<input type="checkbox"/> <input type="checkbox"/> <input type="checkbox"/> <input type="checkbox"/> <input type="checkbox"/>	FACTOR			100 %										
CTRL HEAT	<input type="checkbox"/> <input checked="" type="checkbox"/> <input checked="" type="checkbox"/> <input type="checkbox"/> <input type="checkbox"/>	OCCUPANCY ST.HT SIZE AREA GRADE PRICE AGE REMD CND UNADJ VAL PHYS PHYS VAL FUNC TRUE VAL													
HW/STEAM	<input type="checkbox"/> <input type="checkbox"/> <input type="checkbox"/> <input type="checkbox"/> <input type="checkbox"/>	DWELLING	1.5	SK	1,248	C		1886	2007	A	191,150	26	141,450		127,300
ELECTRIC	<input type="checkbox"/> <input type="checkbox"/> <input type="checkbox"/> <input type="checkbox"/> <input type="checkbox"/>	1 Barn	10	34x54	1,836	C	12.00	1900		A	22,030	95	1,100	DFLT50	600
HEAT PUMP	<input type="checkbox"/> <input type="checkbox"/> <input type="checkbox"/> <input type="checkbox"/> <input type="checkbox"/>	2 Lean - To	8	16x34	544	C	4.80	1900		A	2,610	95	130		100
FLR/WALL	<input type="checkbox"/> <input type="checkbox"/> <input type="checkbox"/> <input type="checkbox"/> <input type="checkbox"/>	3 Pole Bldg	16	32x68	2,176	C	11.87	1965		A	25,830	85	3,870		3,900
STVE/SPCE	<input type="checkbox"/> <input type="checkbox"/> <input type="checkbox"/> <input type="checkbox"/> <input type="checkbox"/>	4 Gar - Pole	7	16x25	400	C	12.00	1920		A	4,800	95	240		200
GEOHERMAL	<input type="checkbox"/> <input type="checkbox"/> <input type="checkbox"/> <input type="checkbox"/> <input type="checkbox"/>	5 Pump Hse	NV*	6x8	48	D		1920		A		95			0
OUTSIDE	<input type="checkbox"/> <input type="checkbox"/> <input type="checkbox"/> <input type="checkbox"/> <input type="checkbox"/>	6 Coop	SV*	15x38	570	C		1900		A	200	95			200
CTRL A/C	<input type="checkbox"/> <input type="checkbox"/> <input type="checkbox"/> <input type="checkbox"/> <input type="checkbox"/>	7 Rfx		5x34	170	C	8.91	1920		A	1,510	95	80		100
PLUMBING	BASE <input checked="" type="checkbox"/>	8													
X FULL BATH		9													
X HALF BATH		10													
X FIXTURES		11													

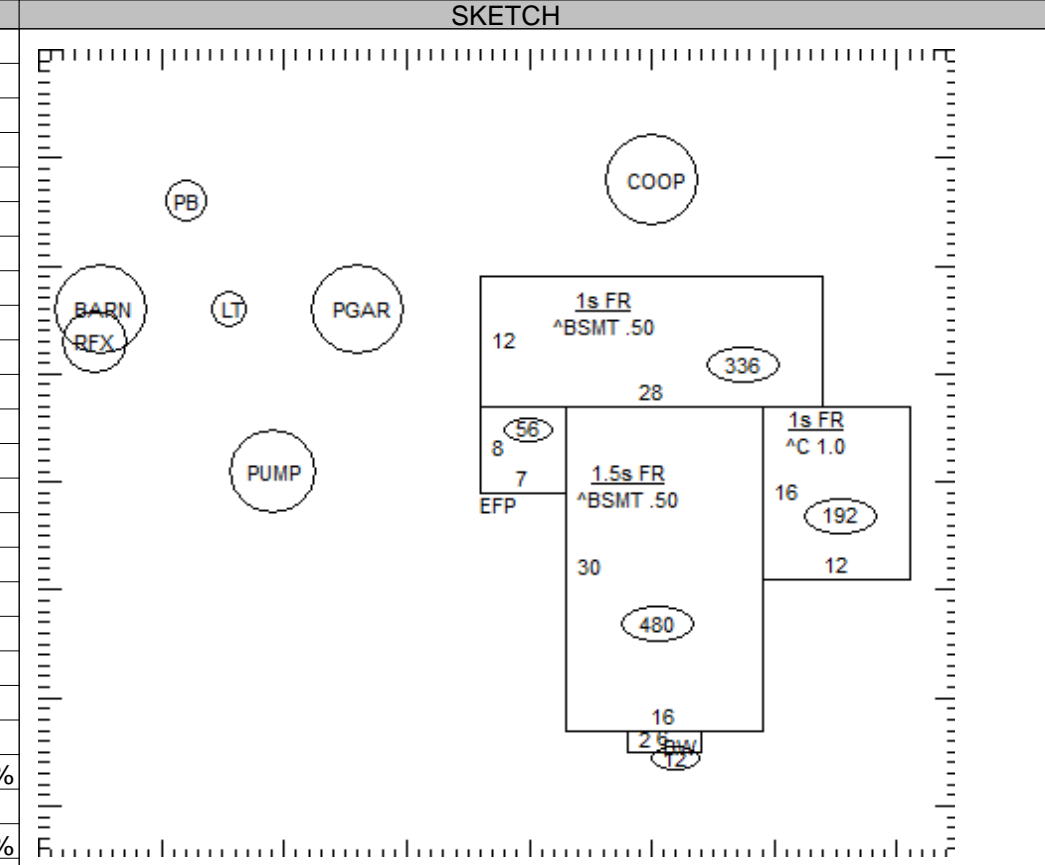

OCCUPANCY	ST.HT	SIZE	AREA	GRADE	PRICE	AGE	REMD	CND	UNADJ VAL	PHYS	PHYS VAL	FUNC	TRUE VAL
DWELLING	1.5	SK	1,248	C		1886	2007	A	191,150	26	141,450		127,300
1 Barn	10	34x54	1,836	C	12.00	1900		A	22,030	95	1,100	DFLT50	600
2 Lean - To	8	16x34	544	C	4.80	1900		A	2,610	95	130		100
3 Pole Bldg	16	32x68	2,176	C	11.87	1965		A	25,830	85	3,870		3,900
4 Gar - Pole	7	16x25	400	C	12.00	1920		A	4,800	95	240		200
5 Pump Hse	NV*	6x8	48	D		1920		A		95			0
6 Coop	SV*	15x38	570	C		1900		A	200	95			200
7 Rfx		5x34	170	C	8.91	1920		A	1,510	95	80		100
8													
9													
10													
11													

01-027500.0100 * Value Override Item TOTAL 132,400

COMMENTS

ELECTRICAL FIRE 06-15-06 /75% FNC CDU
 Dwelling has an Economic Factor of 90% (Rollback Basis=\$145,000)