

BLACKCREEK TWP / PARKWAY SD

01-09-300-004

Property Class: 111

Neighborhood

009011-A100

Map:

Block:

Card:

Bk:

Pg:

01-011200.0100

K & S GAMBLE FARMS LLC

K & S GAMBLE FARMS LLC

12771 RIVER TRAIL RD

ROCKFORD, OH 45882

Created in 2023 From 01-011200.0000 due to Split

LEGAL INFORMATION

PT NW SW

RTS: 001-04-09

Acres:2.6460

**QUALIFIED CREDITS: CAUV:
06362**

	OWNERSHIP	ADDRESS	CITY	STATE	ZIP	DATE	AMOUNT	DEED:CONV#	JS	VALID
1	K & S GAMBLE FARMS LLC	12771 RIVER TRAIL RD	ROCKFORD	OH	45882	06/01/2023	342,000	2:WDC : 299	<input type="checkbox"/>	<input checked="" type="checkbox"/>
2							0	0	<input type="checkbox"/>	<input type="checkbox"/>
3							0	0	<input type="checkbox"/>	<input type="checkbox"/>

X:	<input type="checkbox"/> TTO	LISTER:	DATE:	TIME:	<input type="checkbox"/> LETTER	<input type="checkbox"/> LETTER REC'D	GIS CODE
----	------------------------------	---------	-------	-------	---------------------------------	---------------------------------------	----------

STREET/ROAD	TOPOGRAPHY	PU-UTILITIES-PR	NEIGHBORHOOD	INFLUENCE FACTORS	PROPERTY LOCATION	
<input type="checkbox"/> PAVED <input type="checkbox"/> GRAVEL <input type="checkbox"/> DIRT <input type="checkbox"/> SIDEWALKS <input type="checkbox"/> CURBS	<input type="checkbox"/> LEVEL <input type="checkbox"/> HIGH <input type="checkbox"/> LOW <input type="checkbox"/> ROLLING <input type="checkbox"/> STANDARD	<input type="checkbox"/> WATER <input type="checkbox"/> SEWER <input type="checkbox"/> GAS <input type="checkbox"/> ELECTRIC <input type="checkbox"/> STANDARD	<input type="checkbox"/> IMPROVING <input type="checkbox"/> STATIC <input type="checkbox"/> DECLINING <input type="checkbox"/> OLD <input type="checkbox"/> STANDARD	<input type="checkbox"/> A. NO ROAD <input type="checkbox"/> B. TOPGRHY <input type="checkbox"/> C. Ex Front <input type="checkbox"/> D. QUANTITY <input type="checkbox"/> E. SZ/SHAPE	<input type="checkbox"/> F. RESTRICT <input type="checkbox"/> G. WOOD LT <input type="checkbox"/> H. VACANCY <input type="checkbox"/> I. WATER FRONT <input type="checkbox"/> J. OTHER/CDU	12148 GRAUBERGER RD COMMENT

LAND COMPUTATIONS						
LAND TYPE	SIZE	M	RATE	C	INF	M VALUE C
CR:Crop Land TOTAL	A 1.5010	11,850	3,050		17,350	4,200
0087	A .3890	12,450	3,560		4,840	1,380
0024	A 1.1120	11,250	2,540		12,510	2,820
HS:Home Site	A 1.0000	17,490	17,490		17,490	17,490
RD:Road	A .1450	0	0		0	0
Total Acres: 2.6460					TOTAL 34,840	21,690

VALUATION SUMMARY					
VALUE YEAR	2023	2023	2023	2023	
REASON FOR CHANGE	CAUV	RAPP	CAUV	MISC	
APPRAISED	LAND	21,690	34,840	19,470	34,840
VALUE	IMPR	117,700	117,700	117,700	117,700
	TOTAL	139,390	152,540	137,170	152,540
ASSESSED	LAND	7,590	12,190	6,810	12,190
VALUE	IMPR	41,200	41,200	41,200	41,200
	TOTAL	48,790	53,390	48,010	53,390
POTENTIAL RECOUP	2022=163.75, 2021=162.74, 2020=165.10: Total=491.59				

OCCUPANCY		EXTERIOR		FLOOR	AREA	CONST	VALUE
<input checked="" type="checkbox"/> SF	<input type="checkbox"/> DU	<input type="checkbox"/> TR	<input checked="" type="checkbox"/> WOOD	1	946	FR	155,020
<input type="checkbox"/> CONVERSION			<input type="checkbox"/> STUCCO	.5	252	FR	25,600
BUILDING TYPE		<input checked="" type="checkbox"/> ALM/VYNL					
<input type="checkbox"/> MOBILE HOME			<input type="checkbox"/> CONC BLK				
<input type="checkbox"/> BI/TR LEVEL			<input type="checkbox"/> METAL				
<input type="checkbox"/> MOD/MAN			<input type="checkbox"/> BRICK				
<input type="checkbox"/> _____			<input type="checkbox"/> STONE				
ROOFING		ROOF TYPE					
<input type="checkbox"/> METAL			<input checked="" type="checkbox"/> GABLE				
<input type="checkbox"/> SLT/TLE			<input type="checkbox"/> HIP				
<input checked="" type="checkbox"/> SHINGLES			<input type="checkbox"/> GAMBREL				
<input type="checkbox"/> SHAKES			<input type="checkbox"/> MANSARD				
<input type="checkbox"/> COMPOSITE			<input type="checkbox"/> FLAT				
FLOORS		B	1	2	3	U	
CONCRETE	<input type="checkbox"/>	<input type="checkbox"/>	<input type="checkbox"/>	<input type="checkbox"/>	<input type="checkbox"/>	<input type="checkbox"/>	
WOOD	<input type="checkbox"/>	<input checked="" type="checkbox"/>	<input checked="" type="checkbox"/>	<input type="checkbox"/>	<input type="checkbox"/>	<input type="checkbox"/>	
TILE/COMPO	<input type="checkbox"/>	<input type="checkbox"/>	<input type="checkbox"/>	<input type="checkbox"/>	<input type="checkbox"/>	<input type="checkbox"/>	
CARPET	<input type="checkbox"/>	<input checked="" type="checkbox"/>	<input type="checkbox"/>	<input type="checkbox"/>	<input type="checkbox"/>	<input type="checkbox"/>	
INT. FINISH		B	1	2	3	U	
PLASTER/DW	<input type="checkbox"/>	<input type="checkbox"/>	<input type="checkbox"/>	<input type="checkbox"/>	<input type="checkbox"/>	<input type="checkbox"/>	
PANELING	<input type="checkbox"/>	<input type="checkbox"/>	<input type="checkbox"/>	<input type="checkbox"/>	<input type="checkbox"/>	<input type="checkbox"/>	
UNFINISHED	<input type="checkbox"/>	<input type="checkbox"/>	<input type="checkbox"/>	<input type="checkbox"/>	<input type="checkbox"/>	<input type="checkbox"/>	
ACCOMMODATIONS							
# OF ROOMS		3	2				
BEDROOMS		1	2				
FIREPLACES							
HEAT & AC		B	1	2	3	U	
NO HEAT	<input type="checkbox"/>	<input type="checkbox"/>	<input type="checkbox"/>	<input type="checkbox"/>	<input type="checkbox"/>	<input type="checkbox"/>	
CTRL HEAT	<input type="checkbox"/>	<input checked="" type="checkbox"/>	<input checked="" type="checkbox"/>	<input type="checkbox"/>	<input type="checkbox"/>	<input type="checkbox"/>	
HW/STEAM	<input type="checkbox"/>	<input type="checkbox"/>	<input type="checkbox"/>	<input type="checkbox"/>	<input type="checkbox"/>	<input type="checkbox"/>	
ELECTRIC	<input type="checkbox"/>	<input type="checkbox"/>	<input type="checkbox"/>	<input type="checkbox"/>	<input type="checkbox"/>	<input type="checkbox"/>	
HEAT PUMP	<input type="checkbox"/>	<input type="checkbox"/>	<input type="checkbox"/>	<input type="checkbox"/>	<input type="checkbox"/>	<input type="checkbox"/>	
FLR/WALL	<input type="checkbox"/>	<input type="checkbox"/>	<input type="checkbox"/>	<input type="checkbox"/>	<input type="checkbox"/>	<input type="checkbox"/>	
STVE/SPCE	<input type="checkbox"/>	<input type="checkbox"/>	<input type="checkbox"/>	<input type="checkbox"/>	<input type="checkbox"/>	<input type="checkbox"/>	
GEOTHERMAL	<input type="checkbox"/>	<input type="checkbox"/>	<input type="checkbox"/>	<input type="checkbox"/>	<input type="checkbox"/>	<input type="checkbox"/>	
OUTSIDE	<input type="checkbox"/>	<input type="checkbox"/>	<input type="checkbox"/>	<input type="checkbox"/>	<input type="checkbox"/>	<input type="checkbox"/>	
CTRL A/C	<input type="checkbox"/>	<input checked="" type="checkbox"/>	<input checked="" type="checkbox"/>	<input type="checkbox"/>	<input type="checkbox"/>	<input type="checkbox"/>	
PLUMBING		BASE		<input checked="" type="checkbox"/>			
X FULL BATH	<input type="checkbox"/>	<input type="checkbox"/>	<input type="checkbox"/>	<input type="checkbox"/>	<input type="checkbox"/>	<input type="checkbox"/>	
X HALF BATH	<input type="checkbox"/>	<input type="checkbox"/>	<input type="checkbox"/>	<input type="checkbox"/>	<input type="checkbox"/>	<input type="checkbox"/>	
X FIXTURES	<input type="checkbox"/>	<input type="checkbox"/>	<input type="checkbox"/>	<input type="checkbox"/>	<input type="checkbox"/>	<input type="checkbox"/>	
SUBTOTAL						180,620	
MULTI-FAMILY #	0						0
BUILDING TYPE	100%						0
BSMT FINISH	0 S.F.						0
FIREPLACE #	0						0
HEATING	0 S.F.						0
AIR COND	1,198 S.F.						1,980
PLUMBING #	0						0
GARAGES & CARPORTS						0	
EXTRA FEATURES						11,900	
SUBTOTAL						194,500	
GRADE FACTOR						100 %	
UNADJUSTED VALUE						194,500	
FACTOR						100 %	

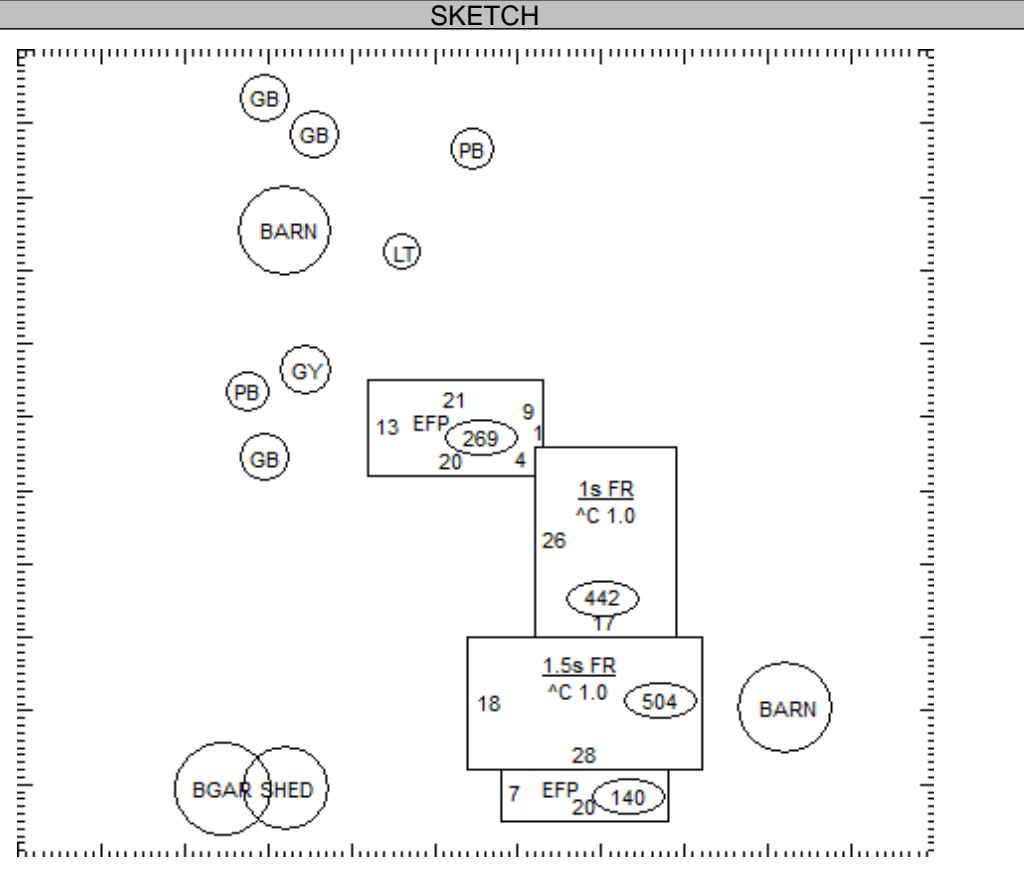

OCCUPANCY	ST.HT	SIZE	AREA	GRADE	PRICE	AGE	REMD	CND	UNADJ VAL	PHYS	PHYS VAL	FUNC	TRUE VAL
DWELLING	1.5	SK	1,198	C		1900		A	194,500	45	106,980		96,300
1 Barn	8	36x60	2,160	C	12.00	1959		A	25,920	90	2,590	DFLT50	1,300
2 Granary	16	28x50	1,400	C	7.70	1947		A	10,780	95	540	DFLT50	300
3 Pole Bldg	16	0x0	1,176	C	12.51	1975		A	14,710	80	2,940		2,900
4 Grain Bin	18	27x20	540	C		1972		A		85			0
5 Grain Bin	18	27x18	486	C		1979		A		77			0
6 Barn	16	38x48	1,824	D	9.60	1900		A	17,510	95	880	DFLT50	400
7 Lean - To	10	16x38	608	D	3.84	1900		A	2,330	95	120		100
8 Pole Bldg	14	48x64	3,072	C	14.39	1974		A	44,210	80	8,840		8,800
9 Grain Bin	18	21x18	378	C		1977		A		80			0
10Shed		10x16	160	C	9.90	1980		A	1,580	77	360		400
11 Gar - Brick		30x56	1,680	C	28.58	1970		A	48,010	85	7,200		7,200

01-011200.0100

TOTAL 117,700

COMMENTS

>>OB Features: 1.8 <Add Concrete Floor>
Dwelling has an Economic Factor of 90%