

GRANVILLE TWP-BURKETTSVILLE CORP / ST HENRY SD
14-34-403-016

Property Class: 510
Neighborhood
002200-TS20
Map: 28B
Block:
Card: 92
Bk: Pg:

22-008200.0000

KREMER DAVID J & KELLY I
KREMER DAVID J & KELLY I
119 JEFFERSON ST
BURKETTSVILLE, OH 45310

LEGAL INFORMATION
GILBERT ADDITION
ALSO N PT LOTS 29 & 31
LOT#: 30

	OWNERSHIP	ADDRESS	CITY	STATE	ZIP	DATE	AMOUNT	DEED:CONV#	JS	VALID
1	KREMER DAVID J & KELLY I	119 JEFFERSON ST	BURKETTSVILLE	OH	45310	06/26/2019	59,000	2:WDC : 438	<input type="checkbox"/>	<input type="checkbox"/>
2	KELLER FARMS	841 BURKETTSVILLE ST HENRY	FORT RECOVERY	OH	45846	04/19/2018	117,500	4:WDC : 387	<input type="checkbox"/>	<input checked="" type="checkbox"/>
3	STACHLER DENNIS L	119 JEFFERSON ST	BURKETTSVILLE	OH	45310	04/19/2018	0	7:WDC : X : 0	<input type="checkbox"/>	<input type="checkbox"/>

X: TTO LISTER: DATE: 03/19/2021 TIME: 12:00:00 AM LETTER LETTER REC'D GIS CODE

STREET/ROAD	TOPOGRAPHY	PU-UTILITIES-PR	NEIGHBORHOOD	INFLUENCE FACTORS				PROPERTY LOCATION	
<input checked="" type="checkbox"/> PAVED <input type="checkbox"/> GRAVEL <input type="checkbox"/> DIRT <input type="checkbox"/> SIDEWALKS <input type="checkbox"/> CURBS	<input checked="" type="checkbox"/> LEVEL <input type="checkbox"/> HIGH <input type="checkbox"/> LOW <input type="checkbox"/> ROLLING <input type="checkbox"/> STANDARD	<input type="checkbox"/> WATER <input type="checkbox"/> SEWER <input checked="" type="checkbox"/> GAS <input checked="" type="checkbox"/> ELECTRIC <input type="checkbox"/> STANDARD	<input type="checkbox"/> IMPROVING <input checked="" type="checkbox"/> STATIC <input type="checkbox"/> DECLINING <input type="checkbox"/> OLD <input type="checkbox"/> STANDARD	<input type="checkbox"/> A. NO ROAD <input type="checkbox"/> B. TOPGRHY <input type="checkbox"/> C. Ex Front <input type="checkbox"/> D. QUANTITY <input type="checkbox"/> E. SZ/SHAPE	<input type="checkbox"/> F. RESTRICT <input type="checkbox"/> G. WOOD LT <input type="checkbox"/> H. VACANCY <input type="checkbox"/> I. WATER FRONT <input type="checkbox"/> J. OTHER/CDU	119 JEFFERSON ST, BURKETTSVILLE			
								COMMENT	
								TY2020:Net Gen=\$1,517.64, Other Assessment=\$847.32 de09 corr bsmnt area-per data mailer DE20 RMV OWN OCC; DID NOT RETURN APP DE21 RMV ALL OUTBLDGS BUT SHED; TTO TriDwell=105 TriOB=105 TriLand=105 (Mod ST:)121	
LAND COMPUTATIONS									
LAND TYPE	SIZE	M	RATE	C	INF	M	VALUE	C	
F:Front	F121 D132	ST169	DP94	ADJ159			20,200	0	
						TOTAL	20,200	0	

VALUATION SUMMARY								
VALUE YEAR	2021	2020	2019	2017	2014	2011	2009	
REASON FOR CHANGE	REMB	RAPP	MISC	RAPP	RAPP	RAPP	MISC	
APPRAISED VALUE	LAND 20,200	20,200	16,000	10,500	9,800	10,500	9,500	
	IMPR 92,800	93,200	82,900	82,900	62,900	67,100	50,700	
	TOTAL 113,000	113,400	98,900	93,400	72,700	77,600	60,200	
ASSESSED VALUE	LAND 7,070	7,070	5,600	3,680	3,430	3,680	3,330	
	IMPR 32,480	32,620	29,020	29,020	22,020	23,490	17,750	
	TOTAL 39,550	39,690	34,620	32,700	25,450	27,170	21,080	

OCCUPANCY	EXTERIOR	FLOOR	AREA	CONST	VALUE
<input checked="" type="checkbox"/> SF <input type="checkbox"/> DU <input type="checkbox"/> TR	<input type="checkbox"/> WOOD	1	990	FR	72,350
<input type="checkbox"/> CONVERSION	<input type="checkbox"/> STUCCO	1	726	BRK	56,770
BUILDING TYPE	<input checked="" type="checkbox"/> ALM/VYNL	.5	120	FR	6,400
<input type="checkbox"/> MOBILE HOME	<input type="checkbox"/> CONC BLK	.5	195	BRK	11,130
<input type="checkbox"/> BI/TR LEVEL	<input type="checkbox"/> METAL				
<input type="checkbox"/> MOD/MAN	<input checked="" type="checkbox"/> BRICK				
<input type="checkbox"/>	<input type="checkbox"/> STONE				

ROOFING	ROOF TYPE
<input checked="" type="checkbox"/> METAL	<input checked="" type="checkbox"/> GABLE
<input type="checkbox"/> SLT/TLE	<input type="checkbox"/> HIP
<input checked="" type="checkbox"/> SHINGLES	<input type="checkbox"/> GAMBREL
<input type="checkbox"/> SHAKES	<input type="checkbox"/> MANSARD
<input type="checkbox"/> COMPOSITE	<input type="checkbox"/> FLAT

FLOORS	B	1	2	3	U
CONCRETE	<input checked="" type="checkbox"/>	<input type="checkbox"/>	<input type="checkbox"/>	<input type="checkbox"/>	<input type="checkbox"/>
WOOD	<input type="checkbox"/>	<input checked="" type="checkbox"/>	<input checked="" type="checkbox"/>	<input checked="" type="checkbox"/>	<input checked="" type="checkbox"/>
TILE/COMPO	<input type="checkbox"/>	<input type="checkbox"/>	<input type="checkbox"/>	<input type="checkbox"/>	<input type="checkbox"/>
CARPET	<input type="checkbox"/>	<input type="checkbox"/>	<input type="checkbox"/>	<input type="checkbox"/>	<input type="checkbox"/>
INT. FINISH	B	1	2	3	U
PLASTER/DW	<input type="checkbox"/>	<input checked="" type="checkbox"/>	<input checked="" type="checkbox"/>	<input checked="" type="checkbox"/>	<input checked="" type="checkbox"/>
PANELING	<input type="checkbox"/>	<input type="checkbox"/>	<input type="checkbox"/>	<input type="checkbox"/>	<input type="checkbox"/>
UNFINISHED	<input checked="" type="checkbox"/>	<input type="checkbox"/>	<input type="checkbox"/>	<input type="checkbox"/>	<input type="checkbox"/>
ACCOMMODATIONS	# OF ROOMS	4	3		
BEDROOMS	1		2		
FIREPLACES					
HEAT & AC	B	1	2	3	U
NO HEAT	<input type="checkbox"/>	<input type="checkbox"/>	<input type="checkbox"/>	<input type="checkbox"/>	<input type="checkbox"/>
CTRL HEAT	<input type="checkbox"/>	<input checked="" type="checkbox"/>	<input checked="" type="checkbox"/>	<input checked="" type="checkbox"/>	<input checked="" type="checkbox"/>
HW/STEAM	<input type="checkbox"/>	<input type="checkbox"/>	<input type="checkbox"/>	<input type="checkbox"/>	<input type="checkbox"/>
ELECTRIC	<input type="checkbox"/>	<input type="checkbox"/>	<input type="checkbox"/>	<input type="checkbox"/>	<input type="checkbox"/>
HEAT PUMP	<input type="checkbox"/>	<input type="checkbox"/>	<input type="checkbox"/>	<input type="checkbox"/>	<input type="checkbox"/>
FLR/WALL	<input type="checkbox"/>	<input type="checkbox"/>	<input type="checkbox"/>	<input type="checkbox"/>	<input type="checkbox"/>
STVE/SPCE	<input type="checkbox"/>	<input type="checkbox"/>	<input type="checkbox"/>	<input type="checkbox"/>	<input type="checkbox"/>
GEO THERMAL	<input type="checkbox"/>	<input type="checkbox"/>	<input type="checkbox"/>	<input type="checkbox"/>	<input type="checkbox"/>
OUTSIDE	<input type="checkbox"/>	<input type="checkbox"/>	<input type="checkbox"/>	<input type="checkbox"/>	<input type="checkbox"/>
CTRL A/C	<input type="checkbox"/>	<input type="checkbox"/>	<input type="checkbox"/>	<input type="checkbox"/>	<input type="checkbox"/>
PLUMBING	BASE	<input checked="" type="checkbox"/>			
X FULL BATH					
X HALF BATH		1			
X FIXTURES					

BSMT	336	4,370
SUBTOTAL		151,020
MULTI-FAMILY #	0	0
BUILDING TYPE	100%	0
BSMT FINISH	0 S.F.	0
FIREPLACE #	0	0
HEATING	0 S.F.	0
AIR COND	0 S.F.	0
PLUMBING #	2	2,200
GARAGES & CARPORTS		10,200
EXTRA FEATURES		3,500
SUBTOTAL		166,920
GRADE FACTOR		107 %
UNADJUSTED VALUE		187,530
FACTOR		100 %

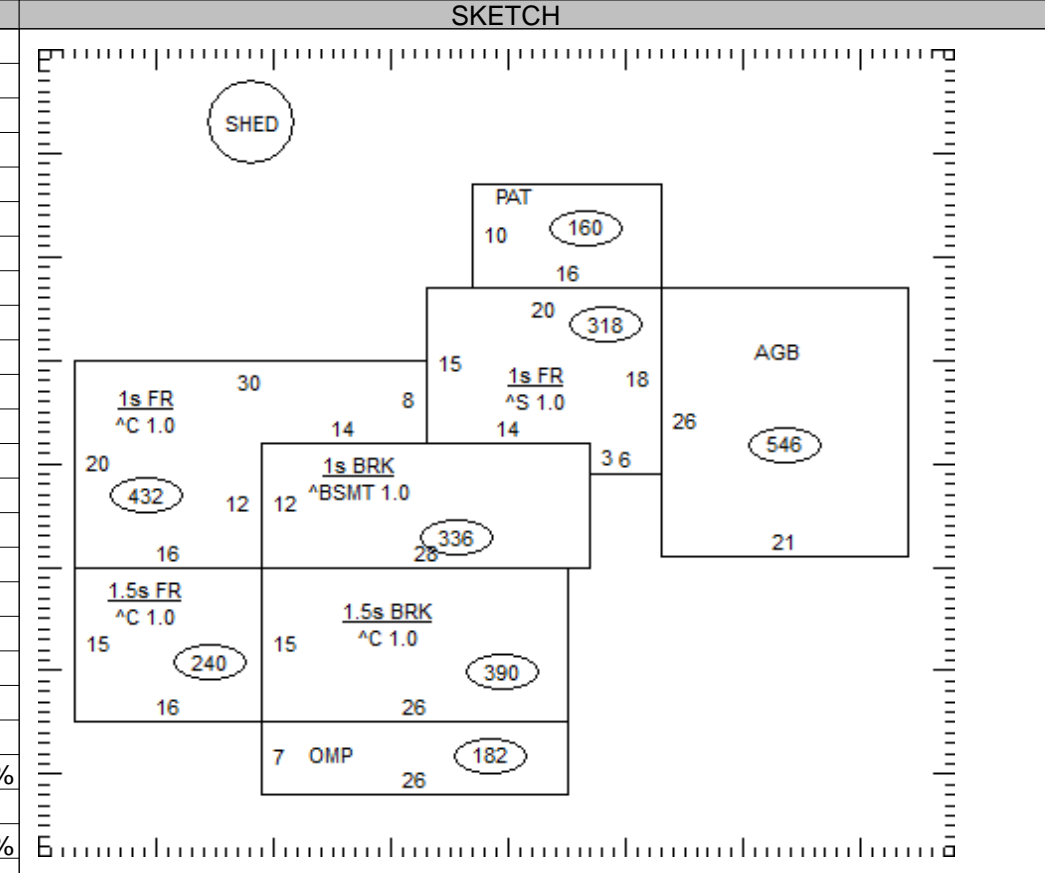

OCCUPANCY	ST.HT	SIZE	AREA	GRADE	PRICE	AGE	REMD	CND	UNADJ VAL	PHYS	PHYS VAL	FUNC	TRUE VAL
DWELLING	1.5	SK	2,031	C		1898		A	187,530	45	103,140		92,800
1 Shed		8x15	120	C		1900		A		95			0
2													
3													
4													
5													
6													
7													
8													
9													
10													
11													

22-008200.0000 TOTAL 92,800

COMMENTS

Dwelling has an Economic Factor of 90%

