



OCCUPANCY	EXTERIOR	FLOOR	AREA	CONST	VALUE
<input checked="" type="checkbox"/> SNGL FMLY	<input type="checkbox"/> WOOD	1	990	FR	72,350
<input type="checkbox"/> DUPLEX	<input type="checkbox"/> STUCCO	1	726	BRK	56,770
<input type="checkbox"/> TRIPLEX	<input checked="" type="checkbox"/> ALM/VYNL	.5	120	FR	6,400
<input type="checkbox"/> CONVR	<input type="checkbox"/> CONC BLK	.5	195	BRK	11,130
<input type="checkbox"/> MOBILE HM	<input type="checkbox"/> METAL				
<input type="checkbox"/> BI/L TRI/L	<input checked="" type="checkbox"/> BRICK				
<input type="checkbox"/> MOD/MAN	<input type="checkbox"/> STONE				

ROOFING	ROOF TYPE
<input checked="" type="checkbox"/> METAL	<input checked="" type="checkbox"/> GABLE
<input type="checkbox"/> SLT/TLE	<input type="checkbox"/> HIP
<input checked="" type="checkbox"/> SHINGLES	<input type="checkbox"/> GAMBREL
<input type="checkbox"/> SHAKES	<input type="checkbox"/> MANSARD
<input type="checkbox"/> COMPOSITE	<input type="checkbox"/> FLAT

FLOORS	B	1	2	3	U
CONCRETE	<input checked="" type="checkbox"/>	<input type="checkbox"/>	<input type="checkbox"/>	<input type="checkbox"/>	<input type="checkbox"/>
WOOD	<input type="checkbox"/>	<input checked="" type="checkbox"/>	<input checked="" type="checkbox"/>	<input checked="" type="checkbox"/>	<input checked="" type="checkbox"/>
TILE/COMPO	<input type="checkbox"/>	<input type="checkbox"/>	<input type="checkbox"/>	<input type="checkbox"/>	<input type="checkbox"/>
CARPET	<input type="checkbox"/>	<input type="checkbox"/>	<input type="checkbox"/>	<input type="checkbox"/>	<input type="checkbox"/>

INT. FINISH	B	1	2	3	U
PLASTER/DW	<input type="checkbox"/>	<input checked="" type="checkbox"/>	<input checked="" type="checkbox"/>	<input checked="" type="checkbox"/>	<input checked="" type="checkbox"/>
PANELING	<input type="checkbox"/>	<input type="checkbox"/>	<input type="checkbox"/>	<input type="checkbox"/>	<input type="checkbox"/>
UNFINISHED	<input checked="" type="checkbox"/>	<input type="checkbox"/>	<input type="checkbox"/>	<input type="checkbox"/>	<input type="checkbox"/>

ACCOMMODATIONS					
# OF ROOMS		4			3
BEDROOMS		1			2
FIREPLACES					
HEAT & AC					

NO HEAT	CTRL HEAT	HW/STEAM	ELECTRIC	HEAT PUMP	FLR/WALL	STVE/SPCE	GEOTHERMAL	OUTSIDE	CTRL A/C
<input type="checkbox"/>	<input type="checkbox"/>	<input type="checkbox"/>	<input type="checkbox"/>	<input type="checkbox"/>	<input type="checkbox"/>	<input type="checkbox"/>	<input type="checkbox"/>	<input type="checkbox"/>	<input type="checkbox"/>
<input type="checkbox"/>	<input checked="" type="checkbox"/>	<input checked="" type="checkbox"/>	<input checked="" type="checkbox"/>	<input checked="" type="checkbox"/>	<input type="checkbox"/>	<input type="checkbox"/>	<input type="checkbox"/>	<input type="checkbox"/>	<input type="checkbox"/>
<input type="checkbox"/>	<input type="checkbox"/>	<input type="checkbox"/>	<input type="checkbox"/>	<input type="checkbox"/>	<input type="checkbox"/>	<input type="checkbox"/>	<input type="checkbox"/>	<input type="checkbox"/>	<input type="checkbox"/>
<input type="checkbox"/>	<input type="checkbox"/>	<input type="checkbox"/>	<input type="checkbox"/>	<input type="checkbox"/>	<input type="checkbox"/>	<input type="checkbox"/>	<input type="checkbox"/>	<input type="checkbox"/>	<input type="checkbox"/>
<input type="checkbox"/>	<input type="checkbox"/>	<input type="checkbox"/>	<input type="checkbox"/>	<input type="checkbox"/>	<input type="checkbox"/>	<input type="checkbox"/>	<input type="checkbox"/>	<input type="checkbox"/>	<input type="checkbox"/>
<input type="checkbox"/>	<input type="checkbox"/>	<input type="checkbox"/>	<input type="checkbox"/>	<input type="checkbox"/>	<input type="checkbox"/>	<input type="checkbox"/>	<input type="checkbox"/>	<input type="checkbox"/>	<input type="checkbox"/>
<input type="checkbox"/>	<input type="checkbox"/>	<input type="checkbox"/>	<input type="checkbox"/>	<input type="checkbox"/>	<input type="checkbox"/>	<input type="checkbox"/>	<input type="checkbox"/>	<input type="checkbox"/>	<input type="checkbox"/>

PLUMBING	BASE
<input checked="" type="checkbox"/>	<input checked="" type="checkbox"/>

X FULL BATH	X HALF BATH	X FIXTURES
	1	

BSMT	AREA	VALUE
	336	4,370
<b>SUBTOTAL</b>		<b>151,020</b>

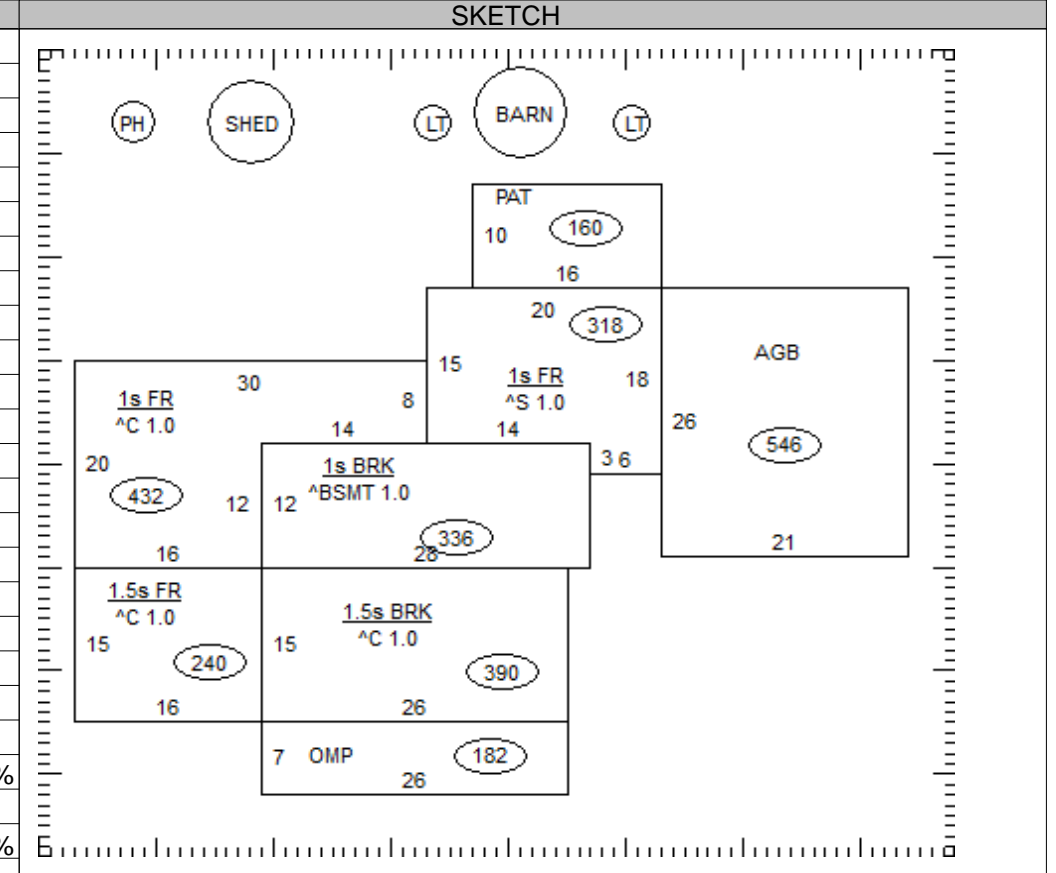

OCCUPANCY	ST.HT	SIZE	AREA	GRADE	PRICE	AGE	REMD	CND	UNADJ VAL	PHYS	PHYS VAL	FUNC	TRUE VAL
DWELLING	1.5	SK	2,031	C		1898		A	166,920	45	91,810		82,600
1 Lean - To		16x24	384	C	3.20	1900		A	1,230	95	60		100
2 Lean - To		8x24	192	C	3.20	1900		A	610	95	30		0
3 Shed		8x15	120	C		1900		A		95			0
4 Barn	14	14x24	336	C	8.00	1900		A	2,690	95	130		100
5 Poultry	10	16x18	288	C	8.25	1900		A	2,380	95	120		100
6													
7													
8													
9													
10													
11													

22-008200.0000 TOTAL 82,900

**COMMENTS**

Dwelling has an Economic Factor of 90%