



22-008000.0000

GRANVILLE TWP-BURKETTSTVILLE CORP / ST HENRY SD  
14-34-403-014

1 OF 1		
PROP. CLASS		
5	1	0
NEIGHBORHOOD		
002200-TS20		
M	28B	
B		
C	94	

**KELLER FARMS**  
KELLER FARMS  
841 BURKETTSTVILLE ST HENRY RD  
FORT RECOVERY, OH 45846

**LEGAL INFORMATION**  
GILBERT ADD  
ALSO N 1/2 VAC ALLEY  
LOTS#: 27 & 28

	OWNERSHIP	ADDRESS	CITY	STATE	ZIP	DATE	AMOUNT	DEED:CONV#	JS	VALID
1	KELLER FARMS	841 BURKETTSTVILLE ST HENRY	FORT RECOVERY	OH	45846	04/19/2018	117,500	4:WDC : 387	<input type="checkbox"/>	<input checked="" type="checkbox"/>
2	STACHLER DENNIS L	119 JEFFERSON ST	BURKETTSTVILLE	OH	45310	04/19/2018	0	7:WDC : X : 0	<input type="checkbox"/>	<input type="checkbox"/>
3	STACHLER DENNIS L	119 JEFFERSON ST PO BOX 112	BURKETTSTVILLE	OH	45310		0	: 0	<input type="checkbox"/>	<input type="checkbox"/>

X:  TTO LISTER: JK DATE: 01/28/2019 TIME: 12:00:00 AM  LETTER  LETTER REC'D GIS CODE

STREET/ROAD	TOPOGRAPHY	PU-UTILITIES-PR	NEIGHBORHOOD	INFLUENCE FACTORS	
<input checked="" type="checkbox"/> PAVED <input type="checkbox"/> GRAVEL <input type="checkbox"/> DIRT <input type="checkbox"/> SIDEWALKS <input type="checkbox"/> CURBS	<input checked="" type="checkbox"/> LEVEL <input type="checkbox"/> HIGH <input type="checkbox"/> LOW <input type="checkbox"/> ROLLING <input type="checkbox"/> STANDARD	<input type="checkbox"/> WATER <input type="checkbox"/> SEWER <input checked="" type="checkbox"/> GAS <input type="checkbox"/> ELECTRIC <input type="checkbox"/> STANDARD	<input type="checkbox"/> IMPROVING <input type="checkbox"/> STATIC <input type="checkbox"/> DECLINING <input type="checkbox"/> OLD <input type="checkbox"/> STANDARD	<input type="checkbox"/> A. NO ROAD <input type="checkbox"/> B. TOPGRHY <input type="checkbox"/> C. Ex Front <input type="checkbox"/> D. QUANTITY <input type="checkbox"/> E. SZ/SHAPE	<input type="checkbox"/> F. RESTRICT <input type="checkbox"/> G. WOOD LT <input type="checkbox"/> H. VACANCY <input type="checkbox"/> I. WATER FRONT <input type="checkbox"/> J. OTHER/CDU

0 JEFFERSON ST,  
**COMMENT**  
TY2018:Net Gen=\$94.00, Other Assessment=\$0.00  
NC20 CHK COMPL; PATIO - WDDK?  
DE19 ADD PARCELS TOGETHER (22-007900.0000)  
DE19 NOH; ADD DWLG

LAND COMPUTATIONS						
LAND TYPE	SIZE	M	RATE	C	INF	M VALUE C
F:Front	F127 D132	ST140	DP94	ADJ132		16,800 0
TOTAL						16,800 0

VALUATION SUMMARY								
VALUE YEAR		2019	2019	2019	2018	2017	2014	2011
REASON FOR CHANGE		MISC	RCLS	NC	MISC	RAPP	RAPP	RAPP
APPRAISED	LAND	16,800	8,800	8,800	6,600	5,900	5,600	5,900
VALUE	IMPR	120,800	120,800	120,800	0	0	0	0
	TOTAL	137,600	129,600	129,600	6,600	5,900	5,600	5,900
ASSESSED	LAND	5,880	3,080	3,080	2,310	2,070	1,960	2,070
VALUE	IMPR	42,280	42,280	42,280	0	0	0	0
	TOTAL	48,160	45,360	45,360	2,310	2,070	1,960	2,070

OCCUPANCY	EXTERIOR
<input checked="" type="checkbox"/> SNGL FMLY <input type="checkbox"/> DUPLEX <input type="checkbox"/> TRIPLEX <input type="checkbox"/> CONVR <input type="checkbox"/> MOBILE HM <input type="checkbox"/> BI/L TRI/L <input type="checkbox"/> MOD/MAN	<input type="checkbox"/> WOOD <input type="checkbox"/> STUCCO <input type="checkbox"/> ALM/VYNL <input type="checkbox"/> CONC BLK <input type="checkbox"/> METAL <input checked="" type="checkbox"/> BRICK <input checked="" type="checkbox"/> STONE

ROOFING	ROOF TYPE
<input type="checkbox"/> METAL <input type="checkbox"/> SLT/TLE <input checked="" type="checkbox"/> SHINGLES <input type="checkbox"/> SHAKES <input type="checkbox"/> COMPOSITE	<input type="checkbox"/> GABLE <input checked="" type="checkbox"/> HIP <input type="checkbox"/> GAMBREL <input type="checkbox"/> MANSARD <input type="checkbox"/> FLAT

FLOORS	B	1	2	3	U
CONCRETE	<input type="checkbox"/>	<input type="checkbox"/>	<input type="checkbox"/>	<input type="checkbox"/>	<input type="checkbox"/>
WOOD	<input type="checkbox"/>	<input checked="" type="checkbox"/>	<input type="checkbox"/>	<input type="checkbox"/>	<input type="checkbox"/>
TILE/COMPO	<input type="checkbox"/>	<input type="checkbox"/>	<input type="checkbox"/>	<input type="checkbox"/>	<input type="checkbox"/>
CARPET	<input type="checkbox"/>	<input checked="" type="checkbox"/>	<input type="checkbox"/>	<input type="checkbox"/>	<input type="checkbox"/>

INT. FINISH	B	1	2	3	U
PLASTER/DW	<input type="checkbox"/>	<input checked="" type="checkbox"/>	<input type="checkbox"/>	<input type="checkbox"/>	<input type="checkbox"/>
PANELING	<input type="checkbox"/>	<input type="checkbox"/>	<input type="checkbox"/>	<input type="checkbox"/>	<input type="checkbox"/>
UNFINISHED	<input checked="" type="checkbox"/>	<input type="checkbox"/>	<input type="checkbox"/>	<input type="checkbox"/>	<input type="checkbox"/>

ACCOMMODATIONS					
# OF ROOMS		7			
BEDROOMS		3			
FIREPLACES					

HEAT & AC	B	1	2	3	U
NO HEAT	<input type="checkbox"/>	<input type="checkbox"/>	<input type="checkbox"/>	<input type="checkbox"/>	<input type="checkbox"/>
CTRL HEAT	<input type="checkbox"/>	<input checked="" type="checkbox"/>	<input type="checkbox"/>	<input type="checkbox"/>	<input type="checkbox"/>
HW/STEAM	<input type="checkbox"/>	<input type="checkbox"/>	<input type="checkbox"/>	<input type="checkbox"/>	<input type="checkbox"/>
ELECTRIC	<input type="checkbox"/>	<input type="checkbox"/>	<input type="checkbox"/>	<input type="checkbox"/>	<input type="checkbox"/>
HEAT PUMP	<input type="checkbox"/>	<input type="checkbox"/>	<input type="checkbox"/>	<input type="checkbox"/>	<input type="checkbox"/>
FLR/WALL	<input type="checkbox"/>	<input type="checkbox"/>	<input type="checkbox"/>	<input type="checkbox"/>	<input type="checkbox"/>
STVE/SPCE	<input type="checkbox"/>	<input type="checkbox"/>	<input type="checkbox"/>	<input type="checkbox"/>	<input type="checkbox"/>
GEOHERMAL	<input type="checkbox"/>	<input type="checkbox"/>	<input type="checkbox"/>	<input type="checkbox"/>	<input type="checkbox"/>
OUTSIDE	<input type="checkbox"/>	<input type="checkbox"/>	<input type="checkbox"/>	<input type="checkbox"/>	<input type="checkbox"/>
CTRL A/C	<input type="checkbox"/>	<input checked="" type="checkbox"/>	<input type="checkbox"/>	<input type="checkbox"/>	<input type="checkbox"/>

PLUMBING	BASE				
X FULL BATH	1				
X HALF BATH	1				
X FIXTURES	1				

FLOOR	AREA	CONST	VALUE
1	2688	BRK	185,310
BSMT	2688		34,940
SUBTOTAL			220,250
MULTI-FAMILY #	0		0
BSMT FINISH	0 S.F.		0
FIREPLACE #	0		0
HEATING	0 S.F.		0
AIR COND	2,688 S.F.		4,030
PLUMBING #	6		6,600
GARAGES & CARPORTS			24,400
EXTRA FEATURES			3,000
SUBTOTAL			258,280
GRADE FACTOR			105 %
UNADJUSTED VALUE			271,190
FACTOR			100 %

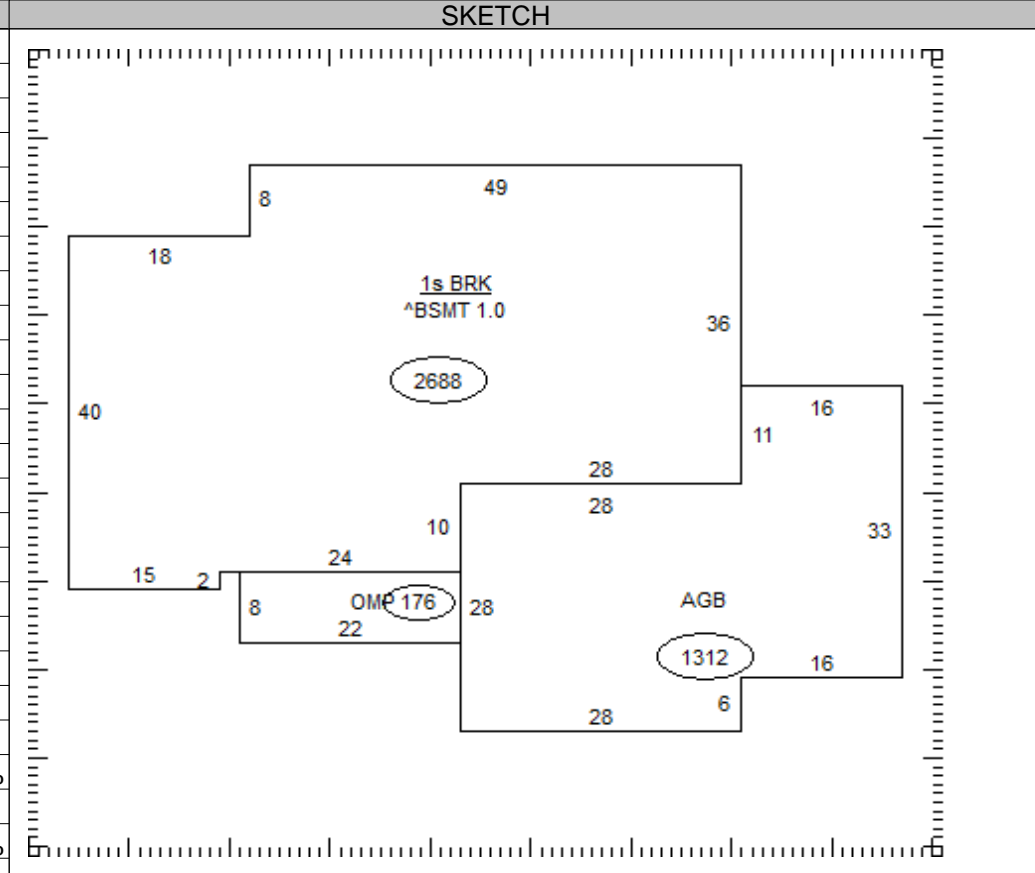

OCCUPANCY	ST.HT	SIZE	AREA	GRADE	PRICE	AGE	REMD	CND	UNADJ VAL	PHYS	PHYS VAL	FUNC	TRUE VAL
DWELLING	1	SK	2,688	C+		2018		G	271,190	1	268,480	INC50	120,800
1													
2													
3													
4													
5													
6													
7													
8													
9													
10													
11													

22-008000.0000 TOTAL 120,800

**COMMENTS**

Dwelling has an Economic Factor of 90%