



22-000300.0000

GRANVILLE TWP-BURKETTSVILLE CORP / ST HENRY SD

14-34-457-006

1 OF 1		
PROP. CLASS		
5	1	0
NEIGHBORHOOD		
002200-TS20		
M	28B	
B		
C	135	

LEISTENSCHNEIDER DEAN & HART STEPHANIE
 LEISTENSCHNEIDER DEAN & HART STEPHANIE
 121 E MAIN ST
 BURKETTSVILLE, OH 45310

LEGAL INFORMATION
 PT SW SE SEC
 (PT SE VILLAGE)
 RTS: 002-15-34

	OWNERSHIP	ADDRESS	CITY	STATE	ZIP	DATE	AMOUNT	DEED:CONV#	JS	VALID
1	LEISTENSCHNEIDER DEAN &	121 E MAIN ST	BURKETTSVILLE	OH	45310	02/21/2017	78,000	WDC : 115	<input type="checkbox"/>	<input checked="" type="checkbox"/>
2	DARLAND DEAN; DARLAND	121 E MAIN ST	BURKETTSVILLE	OH	45310	12/20/2007	70,000	WDC : A : 877	<input type="checkbox"/>	<input type="checkbox"/>
3	DARLAND ELIZABETH A	121 E MAIN ST PO BOX 122 BURKETTSVILLE	OH	45310			0	: 0	<input type="checkbox"/>	<input type="checkbox"/>

X: TTO LISTER: DF DATE: 05/04/2005 TIME: 12:00:00 AM LETTER LETTER REC'D GIS CODE

STREET/ROAD		TOPOGRAPHY	PU-UTILITIES-PR	NEIGHBORHOOD	INFLUENCE FACTORS				PROPERTY LOCATION	
<input checked="" type="checkbox"/> PAVED	<input checked="" type="checkbox"/> GRAVEL	<input checked="" type="checkbox"/> LEVEL	<input type="checkbox"/> WATER	<input type="checkbox"/> IMPROVING	<input type="checkbox"/> A. NO ROAD	<input type="checkbox"/> F. RESTRICT	121 E MAIN ST, BURKETTSVILLE			
<input type="checkbox"/> DIRT	<input type="checkbox"/> SIDEWALKS	<input type="checkbox"/> HIGH	<input type="checkbox"/> SEWER	<input checked="" type="checkbox"/> STATIC	<input type="checkbox"/> B. TOPGRHY	<input type="checkbox"/> G. WOOD LT	COMMENT TY2018:Net Gen=\$1,082.42, Other Assessment=\$2.08 DE16 REVAL DESKTOP REVIEW ADD CPY OVER STP DE18 RMV OWN OCC. Did not return app			
<input type="checkbox"/> CURBS	<input type="checkbox"/> STANDARD	<input type="checkbox"/> LOW	<input checked="" type="checkbox"/> GAS	<input type="checkbox"/> DECLINING	<input type="checkbox"/> C. Ex Front	<input type="checkbox"/> H. VACANCY				
<input type="checkbox"/> ROLLING	<input type="checkbox"/> STANDARD	<input type="checkbox"/> ROLLING	<input checked="" type="checkbox"/> ELECTRIC	<input type="checkbox"/> OLD	<input type="checkbox"/> D. QUANTITY	<input type="checkbox"/> I. WATER FRONT				
<input type="checkbox"/> CURBS	<input type="checkbox"/> STANDARD	<input type="checkbox"/> STANDARD	<input type="checkbox"/> STANDARD	<input type="checkbox"/> STANDARD	<input type="checkbox"/> E. SZ/SHAPE	<input type="checkbox"/> J. OTHER/CDU				

LAND COMPUTATIONS						
LAND TYPE	SIZE	M	RATE	C	INF	M VALUE C
F:Front	F120 D215	ST140 DP114 ADJ160				19,200 0
					TOTAL	19,200 0

VALUATION SUMMARY									
VALUE YEAR	2017	2016	2014	2011					
REASON FOR CHANGE	RAPP	MISC	RAPP	RAPP					
APPRAISED LAND	19,200	18,100	18,100	19,200					
VALUE IMPR	56,800	43,000	42,900	45,700					
TOTAL	76,000	61,100	61,000	64,900					
ASSESSED LAND	6,720	6,340	6,340	6,720					
VALUE IMPR	19,880	15,050	15,020	16,000					
TOTAL	26,600	21,390	21,360	22,720					

OCCUPANCY	EXTERIOR
<input checked="" type="checkbox"/> SNGL FMLY <input type="checkbox"/> DUPLEX <input type="checkbox"/> TRIPLEX <input type="checkbox"/> CONVR <input type="checkbox"/> MOBILE HM <input type="checkbox"/> BI/L TRI/L <input type="checkbox"/> MOD/MAN	<input checked="" type="checkbox"/> WOOD <input type="checkbox"/> STUCCO <input checked="" type="checkbox"/> ALM/VYNL <input type="checkbox"/> CONC BLK <input type="checkbox"/> METAL <input type="checkbox"/> BRICK <input type="checkbox"/> STONE

ROOFING	ROOF TYPE
<input type="checkbox"/> METAL <input type="checkbox"/> SLT/TLE <input checked="" type="checkbox"/> SHINGLES <input type="checkbox"/> SHAKES <input type="checkbox"/> COMPOSITE	<input checked="" type="checkbox"/> GABLE <input type="checkbox"/> HIP <input type="checkbox"/> GAMBREL <input type="checkbox"/> MANSARD <input type="checkbox"/> FLAT

FLOORS	B	1	2	3	U
CONCRETE	<input checked="" type="checkbox"/>	<input type="checkbox"/>	<input type="checkbox"/>	<input type="checkbox"/>	<input type="checkbox"/>
WOOD	<input type="checkbox"/>	<input checked="" type="checkbox"/>	<input type="checkbox"/>	<input type="checkbox"/>	<input type="checkbox"/>
TILE/COMPO	<input type="checkbox"/>	<input type="checkbox"/>	<input type="checkbox"/>	<input type="checkbox"/>	<input type="checkbox"/>
CARPET	<input type="checkbox"/>	<input type="checkbox"/>	<input type="checkbox"/>	<input type="checkbox"/>	<input type="checkbox"/>

INT. FINISH	B	1	2	3	U
PLASTER/DW	<input type="checkbox"/>	<input checked="" type="checkbox"/>	<input type="checkbox"/>	<input type="checkbox"/>	<input type="checkbox"/>
PANELING	<input type="checkbox"/>	<input type="checkbox"/>	<input type="checkbox"/>	<input type="checkbox"/>	<input type="checkbox"/>
UNFINISHED	<input checked="" type="checkbox"/>	<input type="checkbox"/>	<input type="checkbox"/>	<input type="checkbox"/>	<input type="checkbox"/>

ACCOMMODATIONS					
# OF ROOMS		5			
BEDROOMS		2			
FIREPLACES					

HEAT & AC	B	1	2	3	U
NO HEAT	<input type="checkbox"/>	<input type="checkbox"/>	<input type="checkbox"/>	<input type="checkbox"/>	<input type="checkbox"/>
CTRL HEAT	<input type="checkbox"/>	<input checked="" type="checkbox"/>	<input type="checkbox"/>	<input type="checkbox"/>	<input type="checkbox"/>
HW/STEAM	<input type="checkbox"/>	<input type="checkbox"/>	<input type="checkbox"/>	<input type="checkbox"/>	<input type="checkbox"/>
ELECTRIC	<input type="checkbox"/>	<input type="checkbox"/>	<input type="checkbox"/>	<input type="checkbox"/>	<input type="checkbox"/>
HEAT PUMP	<input type="checkbox"/>	<input type="checkbox"/>	<input type="checkbox"/>	<input type="checkbox"/>	<input type="checkbox"/>
FLR/WALL	<input type="checkbox"/>	<input type="checkbox"/>	<input type="checkbox"/>	<input type="checkbox"/>	<input type="checkbox"/>
STVE/SPCE	<input type="checkbox"/>	<input type="checkbox"/>	<input type="checkbox"/>	<input type="checkbox"/>	<input type="checkbox"/>
GEO THERMAL	<input type="checkbox"/>	<input type="checkbox"/>	<input type="checkbox"/>	<input type="checkbox"/>	<input type="checkbox"/>
OUTSIDE	<input type="checkbox"/>	<input type="checkbox"/>	<input type="checkbox"/>	<input type="checkbox"/>	<input type="checkbox"/>
CTRL A/C	<input type="checkbox"/>	<input type="checkbox"/>	<input type="checkbox"/>	<input type="checkbox"/>	<input type="checkbox"/>

PLUMBING	BASE
X FULL BATH	<input checked="" type="checkbox"/>
X HALF BATH	<input type="checkbox"/>
X FIXTURES	<input type="checkbox"/>

FLOOR	AREA	CONST	VALUE
1	936	FR	90,460
BSMT	936		12,170
SUBTOTAL			102,630
MULTI-FAMILY #	0		0
BSMT FINISH	0 S.F.		0
FIREPLACE #	0		0
HEATING	0 S.F.		0
AIR COND	0 S.F.		0
PLUMBING #	0		0
GARAGES & CARPORTS			6,300
EXTRA FEATURES			5,700
SUBTOTAL			114,630
GRADE FACTOR			95 %
UNADJUSTED VALUE			108,900
FACTOR			100 %

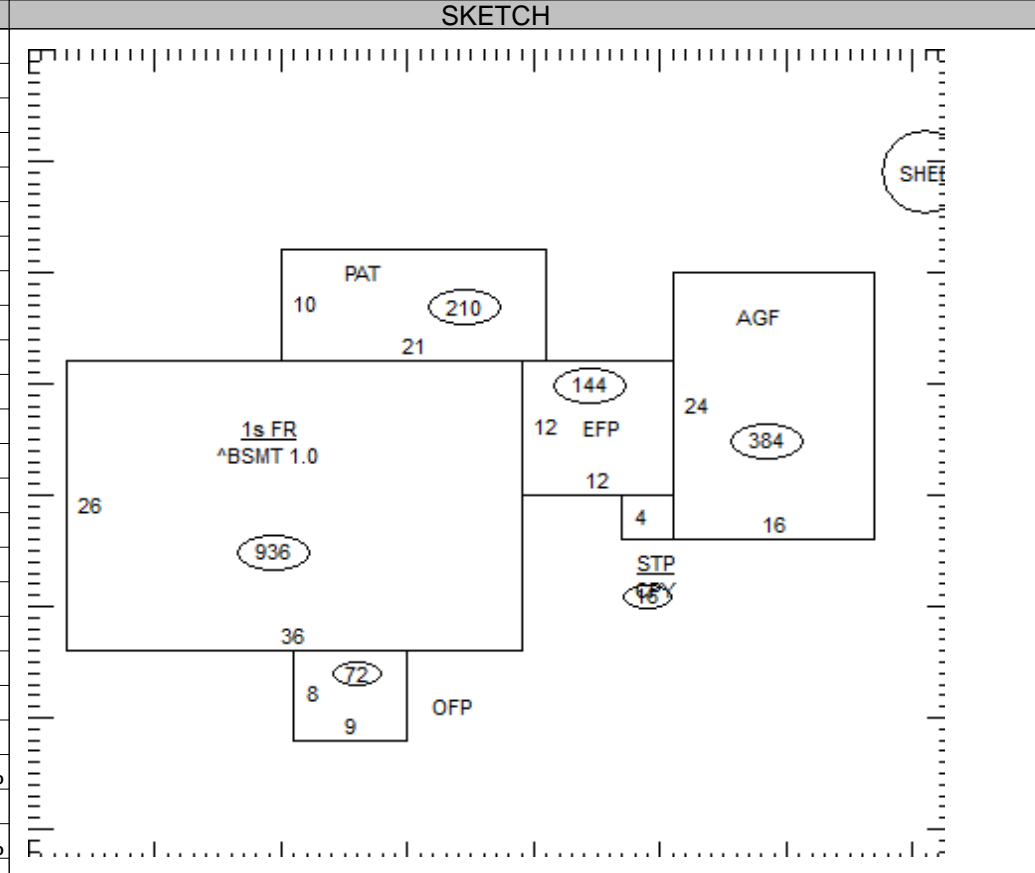

OCCUPANCY	ST.HT	SIZE	AREA	GRADE	PRICE	AGE	REMD	CND	UNADJ VAL	PHYS	PHYS VAL	FUNC	TRUE VAL
DWELLING	1	SK	936	C-		1950		A	108,900	42	63,160		56,800
1 Shed		0x0		C		1990		A		47			0
2													
3													
4													
5													
6													
7													
8													
9													
10													
11													

22-000300.0000	TOTAL	56,800
----------------	--------------	--------

COMMENTS

Dwelling has an Economic Factor of 90%