

14-003300.0000

ANDREWS MICHAEL R

ANDREWS MICHAEL R

806 W COLUMBIA ST

ROCKFORD, OH 45882

## LEGAL INFORMATION

ORIGINAL PLAT

LOT 3

	OWNERSHIP	ADDRESS	CITY	STATE	ZIP	DATE	AMOUNT	DEED:CONV#	JS	VALID
1	ANDREWS MICHAEL R	806 W COLUMBIA ST	ROCKFORD	OH	45882	03/18/2019	30,000	WDC : 164	<input type="checkbox"/>	<input checked="" type="checkbox"/>
2	BRODBECK MAX E	34 E MAIN ST	MONTEZUMA	OH	45866	06/14/1999	79,500	: A : 0	<input type="checkbox"/>	<input checked="" type="checkbox"/>
3							0	0	<input type="checkbox"/>	<input type="checkbox"/>

X:	<input type="checkbox"/> TTO	LISTER: HK	DATE: 04/05/2018	TIME: 12:00:00 AM	<input type="checkbox"/> LETTER	<input type="checkbox"/> LETTER REC'D	GIS CODE
----	------------------------------	------------	------------------	-------------------	---------------------------------	---------------------------------------	----------

STREET/ROAD	TOPOGRAPHY	PU-UTILITIES-PR	NEIGHBORHOOD	INFLUENCE FACTORS				PROPERTY LOCATION
<input checked="" type="checkbox"/> PAVED <input type="checkbox"/> GRAVEL <input type="checkbox"/> DIRT <input type="checkbox"/> SIDEWALKS <input type="checkbox"/> CURBS	<input checked="" type="checkbox"/> LEVEL <input type="checkbox"/> HIGH <input type="checkbox"/> LOW <input type="checkbox"/> ROLLING <input type="checkbox"/> STANDARD	<input type="checkbox"/> WATER <input type="checkbox"/> SEWER <input checked="" type="checkbox"/> GAS <input checked="" type="checkbox"/> ELECTRIC <input type="checkbox"/> STANDARD	<input type="checkbox"/> IMPROVING <input checked="" type="checkbox"/> STATIC <input type="checkbox"/> DECLINING <input type="checkbox"/> OLD <input type="checkbox"/> STANDARD	<input type="checkbox"/> A. NO ROAD <input type="checkbox"/> B. TOPGRHY <input type="checkbox"/> C. Ex Front <input type="checkbox"/> D. QUANTITY <input type="checkbox"/> E. SZ/SHAPE	<input type="checkbox"/> F. RESTRICT <input type="checkbox"/> G. WOOD LT <input type="checkbox"/> H. VACANCY <input type="checkbox"/> I. WATER FRONT <input type="checkbox"/> J. OTHER/CDU	62 E MAIN ST, MONTEZUMA		
COMMENT								
TY2018:Net Gen=\$369.62, Other Assessment=\$44.00 DE18 TT RENTER/COSMETIC REPAIRS DONE/RMV DE17 NOH/ NO INDICATION OF RMDL DE16 FIRE 05/23/16- ALLOW FNC DE11 CORR SH								

LAND COMPUTATIONS							
LAND TYPE	SIZE	M	RATE	C	INF	M	VALUE
F:Front	F82 D165	ST90 DP105 ADJ95				7,800	0
TOTAL						7,800	0

VALUATION SUMMARY					
VALUE YEAR	2017	2016	2014	2011	
REASON FOR CHANGE	RAPP	REMB	RAPP	RAPP	
APPRaised VALUE	<u>LAND</u> 7,800	7,400	7,400	7,800	
	<u>IMPR</u> 15,500	12,500	49,200	52,000	
	<u>TOTAL</u> 23,300	19,900	56,600	59,800	
ASSESSED VALUE	<u>LAND</u> 2,730	2,590	2,590	2,730	
	<u>IMPR</u> 5,430	4,380	17,220	18,200	
	<u>TOTAL</u> 8,160	6,970	19,810	20,930	

OCCUPANCY	EXTERIOR	FLOOR	AREA	CONST	VALUE
<input checked="" type="checkbox"/> SNGL FMLY	<input type="checkbox"/> WOOD	1	1182	FR	103,350
<input type="checkbox"/> DUPLEX	<input type="checkbox"/> STUCCO	.25	145	FR	9,630
<input type="checkbox"/> TRIPLEX	<input checked="" type="checkbox"/> ALM/VYNL				
<input type="checkbox"/> CONVR	<input type="checkbox"/> CONC BLK				
<input type="checkbox"/> MOBILE HM	<input type="checkbox"/> METAL				
<input type="checkbox"/> BI/L TRI/L	<input type="checkbox"/> BRICK				
<input type="checkbox"/> MOD/MAN	<input type="checkbox"/> STONE				

ROOFING	ROOF TYPE
<input type="checkbox"/> METAL	<input checked="" type="checkbox"/> GABLE
<input type="checkbox"/> SLT/TLE	<input type="checkbox"/> HIP
<input checked="" type="checkbox"/> SHINGLES	<input type="checkbox"/> GAMBREL
<input type="checkbox"/> SHAKES	<input type="checkbox"/> MANSARD
<input type="checkbox"/> COMPOSITE	<input type="checkbox"/> FLAT

BSMT	520	6,760
<b>SUBTOTAL</b>		<b>119,740</b>
<b>FLOORS</b>	<b>B 1 2 3 U</b>	
CONCRETE	<input type="checkbox"/> <input type="checkbox"/> <input type="checkbox"/> <input type="checkbox"/> <input type="checkbox"/>	
WOOD	<input type="checkbox"/> <input checked="" type="checkbox"/> <input type="checkbox"/> <input type="checkbox"/> <input type="checkbox"/>	
TILE/COMPO	<input type="checkbox"/> <input type="checkbox"/> <input type="checkbox"/> <input type="checkbox"/> <input type="checkbox"/>	
CARPET	<input type="checkbox"/> <input type="checkbox"/> <input type="checkbox"/> <input type="checkbox"/> <input type="checkbox"/>	
<b>INT. FINISH</b>	<b>B 1 2 3 U</b>	
PLASTER/DW	<input type="checkbox"/> <input checked="" type="checkbox"/> <input type="checkbox"/> <input type="checkbox"/> <input type="checkbox"/>	
PANELING	<input type="checkbox"/> <input type="checkbox"/> <input type="checkbox"/> <input type="checkbox"/> <input type="checkbox"/>	
UNFINISHED	<input type="checkbox"/> <input type="checkbox"/> <input type="checkbox"/> <input type="checkbox"/> <input type="checkbox"/>	
<b>ACCOMMODATIONS</b>		
# OF ROOMS	6	
BEDROOMS	1	
FIREPLACES		
HEAT & AC	<b>B 1 2 3 U</b>	
NO HEAT	<input type="checkbox"/> <input type="checkbox"/> <input type="checkbox"/> <input type="checkbox"/> <input type="checkbox"/>	
CTRL HEAT	<input type="checkbox"/> <input checked="" type="checkbox"/> <input type="checkbox"/> <input type="checkbox"/> <input type="checkbox"/>	
HW/STEAM	<input type="checkbox"/> <input type="checkbox"/> <input type="checkbox"/> <input type="checkbox"/> <input type="checkbox"/>	
ELECTRIC	<input type="checkbox"/> <input type="checkbox"/> <input type="checkbox"/> <input type="checkbox"/> <input type="checkbox"/>	
HEAT PUMP	<input type="checkbox"/> <input type="checkbox"/> <input type="checkbox"/> <input type="checkbox"/> <input type="checkbox"/>	
FLR/WALL	<input type="checkbox"/> <input type="checkbox"/> <input type="checkbox"/> <input type="checkbox"/> <input type="checkbox"/>	
STVE/SPCE	<input type="checkbox"/> <input type="checkbox"/> <input type="checkbox"/> <input type="checkbox"/> <input type="checkbox"/>	
GEO THERMAL	<input type="checkbox"/> <input type="checkbox"/> <input type="checkbox"/> <input type="checkbox"/> <input type="checkbox"/>	
OUTSIDE	<input type="checkbox"/> <input type="checkbox"/> <input type="checkbox"/> <input type="checkbox"/> <input type="checkbox"/>	
CTRL A/C	<input type="checkbox"/> <input type="checkbox"/> <input type="checkbox"/> <input type="checkbox"/> <input type="checkbox"/>	
PLUMBING	<b>BASE</b> <input checked="" type="checkbox"/>	
X FULL BATH		
X HALF BATH		
X FIXTURES		

MULTI-FAMILY #	0	0
BSMT FINISH	0 S.F.	0
FIREPLACE #	0	0
HEATING	0 S.F.	0
AIR COND	0 S.F.	0
PLUMBING #	0	0
GARAGES & CARPORTS		0
EXTRA FEATURES		4,700
<b>SUBTOTAL</b>		<b>124,440</b>
GRADE FACTOR		100 %
<b>UNADJUSTED VALUE</b>		<b>124,440</b>
FACTOR		100 %

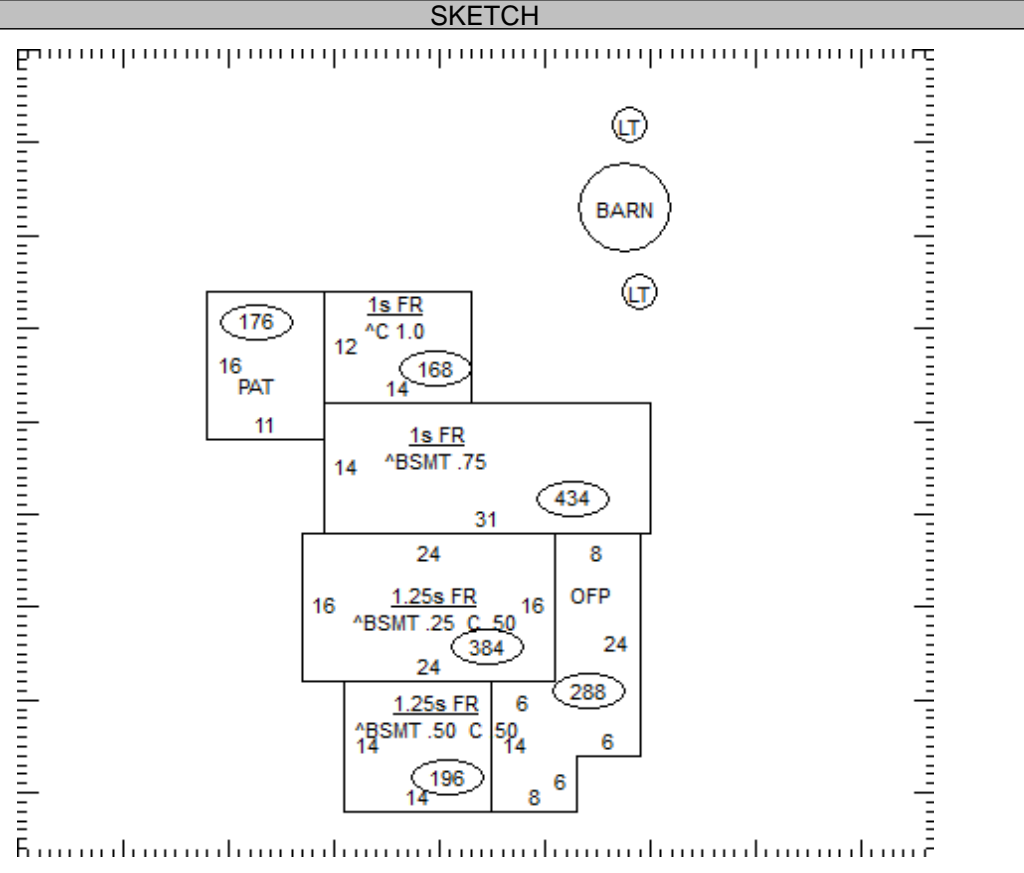

OCCUPANCY	ST.HT	SIZE	AREA	GRADE	PRICE	AGE	REMD	CND	UNADJ VAL	PHYS	PHYS VAL	FUNC	TRUE VAL
DWELLING	1.25	SK	1,327	C		1910		A	124,440	45	68,440	CDU75	15,200
1 Lean - To	8	20x39	780	C	3.20	1910		F	2,500	95	130		100
2 Lean - To	8	20x39	780	C	3.20	1910		F	2,500	95	130		100
3 Barn	12	22x39	858	D	6.40	1910		F	5,490	95	270	DFLT50	100
4													
5													
6													
7													
8													
9													
10													
11													

14-003300.0000	<b>TOTAL</b>	15,500
----------------	--------------	--------

**COMMENTS**

MAIN/HIGH ST  
Dwelling has an Economic Factor of 89%