

OCCUPANCY	EXTERIOR	FLOOR	AREA	CONST	VALUE
<input checked="" type="checkbox"/> SNGL FMLY	<input checked="" type="checkbox"/> WOOD	1	1938	FR	136,400
<input type="checkbox"/> DUPLEX	<input type="checkbox"/> STUCCO	.25	54	FR	3,120
<input type="checkbox"/> TRIPLEX	<input checked="" type="checkbox"/> ALM/VYNL	2ND	1409	FR	47,600
<input type="checkbox"/> CONVR	<input type="checkbox"/> CONC BLK				
<input type="checkbox"/> MOBILE HM	<input type="checkbox"/> METAL				
<input type="checkbox"/> BI/L TRI/L	<input checked="" type="checkbox"/> BRICK				
<input type="checkbox"/> MOD/MAN	<input type="checkbox"/> STONE				

ROOFING	ROOF TYPE
<input type="checkbox"/> METAL	<input checked="" type="checkbox"/> GABLE
<input type="checkbox"/> SLT/TLE	<input type="checkbox"/> HIP
<input checked="" type="checkbox"/> SHINGLES	<input type="checkbox"/> GAMBREL
<input type="checkbox"/> SHAKES	<input type="checkbox"/> MANSARD
<input type="checkbox"/> COMPOSITE	<input type="checkbox"/> FLAT

FLOORS	B	1	2	3	U
CONCRETE	<input type="checkbox"/>	<input type="checkbox"/>	<input type="checkbox"/>	<input type="checkbox"/>	<input type="checkbox"/>
WOOD	<input type="checkbox"/>	<input checked="" type="checkbox"/>	<input type="checkbox"/>	<input type="checkbox"/>	<input type="checkbox"/>
TILE/COMPO	<input type="checkbox"/>	<input checked="" type="checkbox"/>	<input type="checkbox"/>	<input type="checkbox"/>	<input type="checkbox"/>
CARPET	<input type="checkbox"/>	<input checked="" type="checkbox"/>	<input checked="" type="checkbox"/>	<input checked="" type="checkbox"/>	<input type="checkbox"/>

INT. FINISH	B	1	2	3	U
PLASTER/DW	<input type="checkbox"/>	<input checked="" type="checkbox"/>	<input checked="" type="checkbox"/>	<input checked="" type="checkbox"/>	<input type="checkbox"/>
PANELING	<input type="checkbox"/>	<input type="checkbox"/>	<input type="checkbox"/>	<input type="checkbox"/>	<input type="checkbox"/>
UNFINISHED	<input type="checkbox"/>	<input type="checkbox"/>	<input type="checkbox"/>	<input type="checkbox"/>	<input type="checkbox"/>

ACCOMMODATIONS					
# OF ROOMS	4	2			
BEDROOMS	1	2			
FIREPLACES					
HEAT & AC	B	1	2	3	U
NO HEAT	<input type="checkbox"/>	<input type="checkbox"/>	<input type="checkbox"/>	<input type="checkbox"/>	<input type="checkbox"/>
CTRL HEAT	<input type="checkbox"/>	<input checked="" type="checkbox"/>	<input checked="" type="checkbox"/>	<input checked="" type="checkbox"/>	<input type="checkbox"/>
HW/STEAM	<input type="checkbox"/>	<input type="checkbox"/>	<input type="checkbox"/>	<input type="checkbox"/>	<input type="checkbox"/>
ELECTRIC	<input type="checkbox"/>	<input type="checkbox"/>	<input type="checkbox"/>	<input type="checkbox"/>	<input type="checkbox"/>
HEAT PUMP	<input type="checkbox"/>	<input type="checkbox"/>	<input type="checkbox"/>	<input type="checkbox"/>	<input type="checkbox"/>
FLR/WALL	<input type="checkbox"/>	<input type="checkbox"/>	<input type="checkbox"/>	<input type="checkbox"/>	<input type="checkbox"/>
STVE/SPCE	<input type="checkbox"/>	<input type="checkbox"/>	<input type="checkbox"/>	<input type="checkbox"/>	<input type="checkbox"/>
GEO THERMAL	<input type="checkbox"/>	<input type="checkbox"/>	<input type="checkbox"/>	<input type="checkbox"/>	<input type="checkbox"/>
OUTSIDE	<input type="checkbox"/>	<input type="checkbox"/>	<input type="checkbox"/>	<input type="checkbox"/>	<input type="checkbox"/>
CTRL A/C	<input type="checkbox"/>	<input checked="" type="checkbox"/>	<input checked="" type="checkbox"/>	<input checked="" type="checkbox"/>	<input type="checkbox"/>

PLUMBING	BASE
X FULL BATH	1
X HALF BATH	1
X FIXTURES	

SUBTOTAL	VALUE
MULTI-FAMILY #	0
BSMT FINISH	0 S.F.
FIREPLACE #	0
HEATING	0 S.F.
AIR COND	3,401 S.F.
PLUMBING #	5
GARAGES & CARPORTS	19,900
EXTRA FEATURES	24,700
SUBTOTAL	242,320
GRADE FACTOR	120 %
UNADJUSTED VALUE	290,780
FACTOR	100 %

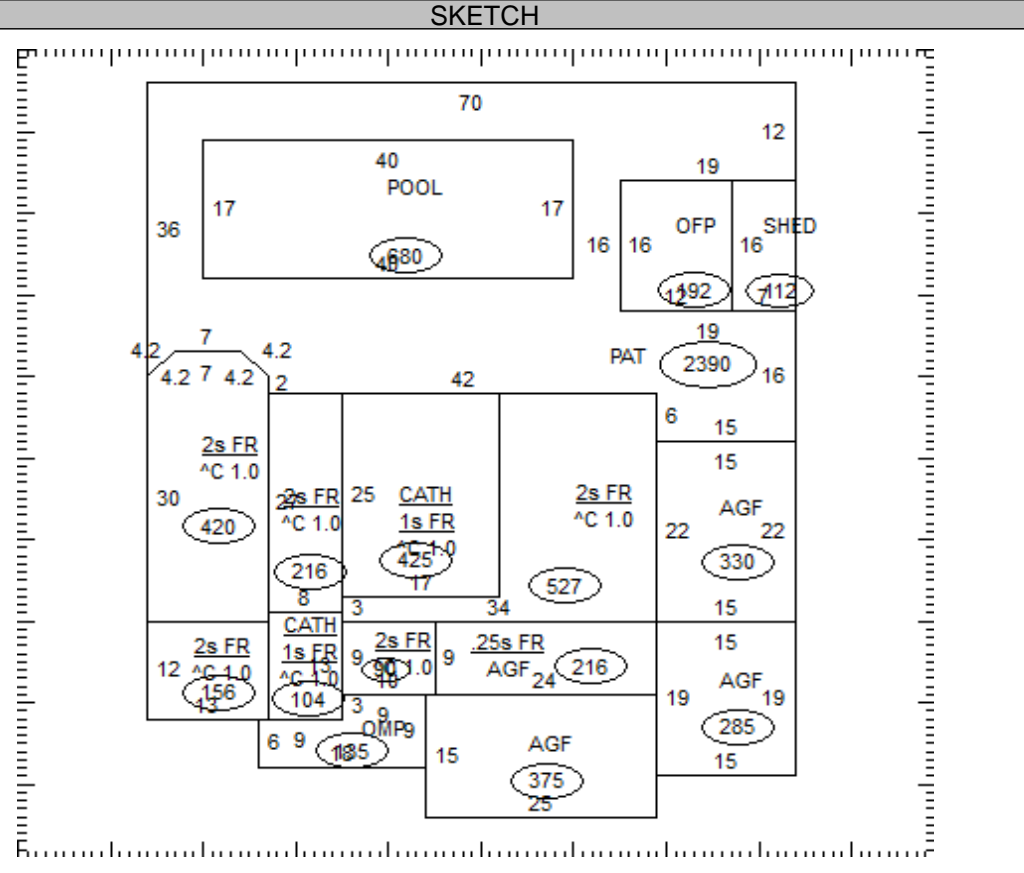

OCCUPANCY	ST.HT	SIZE	AREA	GRADE	PRICE	AGE	REMD	CND	UNADJ VAL	PHYS	PHYS VAL	FUNC	TRUE VAL
DWELLING	2	SK	3,401	B		2003		A	290,780	12	255,890		268,700
1 Shed		16x7	112	C		2018		A		2			0
2 Pool - Inground		17x40	680	C	25.00	2018		A	17,000	2	16,660	USE30	11,700
3 OFP		16x12	192	C	14.58	2018		A	2,800	2	2,740		2,700
4													
5													
6													
7													
8													
9													
10													
11													

09-076300.0104	TOTAL	283,100
----------------	--------------	---------

COMMENTS

15X8 BRICK TRIM
Dwelling has an Economic Factor of 105%