

1 OF 1		
PROP. CLASS		
5	1	0
NEIGHBORHOOD		
009095-R150		
M	04A	
B		
C	03	

09-065300.0000

**GRUNDEN MARA R**  
 GRUNDEN MARA R  
 7118 COTTONWOOD DR  
 CELINA, OH 45822

**LEGAL INFORMATION**  
 NE NW NW

RTS: 003-06-21  
 Acres:0.6450

	OWNERSHIP	ADDRESS	CITY	STATE	ZIP	DATE	AMOUNT	DEED:CONV#	JS	VALID
1	GRUNDEN MARA R	7118 COTTONWOOD DR	CELINA	OH	45822	04/27/2016	135,000	WDC : 276	<input type="checkbox"/>	<input checked="" type="checkbox"/>
2	KLOSTERMAN DAVID H	7118 COTTONWOOD RD	CELINA	OH	45822		0	: 0	<input type="checkbox"/>	<input type="checkbox"/>
3							0	0	<input type="checkbox"/>	<input type="checkbox"/>

X:  TTO LISTER: DATE: 08/18/2009 TIME: 12:00:00 AM  LETTER  LETTER REC'D GIS CODE

STREET/ROAD	TOPOGRAPHY	PU-UTILITIES-PR	NEIGHBORHOOD	INFLUENCE FACTORS	PROPERTY LOCATION	
<input checked="" type="checkbox"/> PAVED <input type="checkbox"/> GRAVEL <input type="checkbox"/> DIRT <input type="checkbox"/> SIDEWALKS <input type="checkbox"/> CURBS	<input checked="" type="checkbox"/> LEVEL <input type="checkbox"/> HIGH <input type="checkbox"/> LOW <input type="checkbox"/> ROLLING <input type="checkbox"/> STANDARD	<input type="checkbox"/> WATER <input type="checkbox"/> SEWER <input type="checkbox"/> GAS <input type="checkbox"/> ELECTRIC <input checked="" type="checkbox"/> STANDARD	<input type="checkbox"/> IMPROVING <input checked="" type="checkbox"/> STATIC <input type="checkbox"/> DECLINING <input type="checkbox"/> OLD <input type="checkbox"/> STANDARD	<input type="checkbox"/> A. NO ROAD <input type="checkbox"/> B. TOPGRHY <input type="checkbox"/> C. Ex Front <input type="checkbox"/> D. QUANTITY <input type="checkbox"/> E. SZ/SHAPE	<input type="checkbox"/> F. RESTRICT <input type="checkbox"/> G. WOOD LT <input type="checkbox"/> H. VACANCY <input type="checkbox"/> I. WATER FRONT <input type="checkbox"/> J. OTHER/CDU	7118 COTTONWOOD RD, CELINA  COMMENT TY2018:Net Gen=\$1,864.48, Other Assessment=\$0.00 DE11 ADD BW'S DE09 ADD CA/PER DATA MAILER DE08 ADD DET GAR, CORR DWELLNG SK DE17 DESKTOP REVIEW//ADD PATIO; CORR CATH TO VAULT CEILING

LAND COMPUTATIONS						
LAND TYPE	SIZE	M	RATE	C	INF	M VALUE C
HS:Home Site <1 @ 16500*0.88	AC:0.645	14520				14,500 0
Total Acres: .6450					TOTAL	14,500 0

VALUATION SUMMARY								
VALUE YEAR	2017	2017	2017	2014	2013	2011	2009	
REASON FOR CHANGE	RAPP	MISC	MISC	RAPP	MISC	RAPP	MISC	
APPRAISED	LAND	14,500	14,300	14,300	14,300	13,200	13,400	13,400
VALUE	IMPR	106,400	107,500	120,300	113,300	104,900	104,900	101,900
	TOTAL	120,900	121,800	134,600	127,600	118,100	118,300	115,300
ASSESSED	LAND	5,080	5,010	5,010	5,010	4,620	4,690	4,690
VALUE	IMPR	37,240	37,630	42,110	39,660	36,720	36,720	35,670
	TOTAL	42,320	42,640	47,120	44,670	41,340	41,410	40,360

OCCUPANCY	EXTERIOR	FLOOR	AREA	CONST	VALUE
<input checked="" type="checkbox"/> SNGL FMLY	<input type="checkbox"/> WOOD	1	1328	FR	107,740
<input type="checkbox"/> DUPLEX	<input type="checkbox"/> STUCCO	.25	98	FR	6,040
<input type="checkbox"/> TRIPLEX	<input checked="" type="checkbox"/> ALM/VYNL				
<input type="checkbox"/> CONVR	<input type="checkbox"/> CONC BLK				
<input type="checkbox"/> MOBILE HM	<input type="checkbox"/> METAL				
<input type="checkbox"/> BI/L TRI/L	<input type="checkbox"/> BRICK				
<input type="checkbox"/> MOD/MAN	<input type="checkbox"/> STONE				
ROOFING	ROOF TYPE				
<input type="checkbox"/> METAL	<input checked="" type="checkbox"/> GABLE				
<input type="checkbox"/> SLT/TLE	<input type="checkbox"/> HIP				
<input checked="" type="checkbox"/> SHINGLES	<input type="checkbox"/> GAMBREL				
<input type="checkbox"/> SHAKES	<input type="checkbox"/> MANSARD				
<input type="checkbox"/> COMPOSITE	<input type="checkbox"/> FLAT				
SUBTOTAL					113,780

FLOORS	B	1	2	3	U		
CONCRETE	<input type="checkbox"/>	<input type="checkbox"/>	<input type="checkbox"/>	<input type="checkbox"/>	<input type="checkbox"/>	MULTI-FAMILY #	0
WOOD	<input type="checkbox"/>	<input type="checkbox"/>	<input type="checkbox"/>	<input type="checkbox"/>	<input type="checkbox"/>	BSMT FINISH	0 S.F.
TILE/COMPO	<input type="checkbox"/>	<input checked="" type="checkbox"/>	<input type="checkbox"/>	<input type="checkbox"/>	<input type="checkbox"/>	FIREPLACE #	0
CARPET	<input type="checkbox"/>	<input checked="" type="checkbox"/>	<input checked="" type="checkbox"/>	<input type="checkbox"/>	<input type="checkbox"/>	HEATING	0 S.F.
INT. FINISH	B	1	2	3	U	AIR COND	1,426 S.F.
PLASTER/DW	<input type="checkbox"/>	<input checked="" type="checkbox"/>	<input checked="" type="checkbox"/>	<input type="checkbox"/>	<input type="checkbox"/>	PLUMBING #	0
PANELING	<input type="checkbox"/>	<input type="checkbox"/>	<input type="checkbox"/>	<input type="checkbox"/>	<input type="checkbox"/>	GARAGES & CARPORTS	10,300
UNFINISHED	<input type="checkbox"/>	<input type="checkbox"/>	<input type="checkbox"/>	<input type="checkbox"/>	<input type="checkbox"/>	EXTRA FEATURES	8,900
ACCOMMODATIONS							
# OF ROOMS		6	1			GRADE FACTOR	100 %
BEDROOMS		3				UNADJUSTED VALUE	135,120
FIREPLACES						FACTOR	100 %
HEAT & AC	B	1	2	3	U		
NO HEAT	<input type="checkbox"/>	<input type="checkbox"/>	<input type="checkbox"/>	<input type="checkbox"/>	<input type="checkbox"/>		
CTRL HEAT	<input type="checkbox"/>	<input checked="" type="checkbox"/>	<input checked="" type="checkbox"/>	<input type="checkbox"/>	<input type="checkbox"/>		
HW/STEAM	<input type="checkbox"/>	<input type="checkbox"/>	<input type="checkbox"/>	<input type="checkbox"/>	<input type="checkbox"/>		
ELECTRIC	<input type="checkbox"/>	<input type="checkbox"/>	<input type="checkbox"/>	<input type="checkbox"/>	<input type="checkbox"/>		
HEAT PUMP	<input type="checkbox"/>	<input type="checkbox"/>	<input type="checkbox"/>	<input type="checkbox"/>	<input type="checkbox"/>		
FLR/WALL	<input type="checkbox"/>	<input type="checkbox"/>	<input type="checkbox"/>	<input type="checkbox"/>	<input type="checkbox"/>		
STVE/SPCE	<input type="checkbox"/>	<input type="checkbox"/>	<input type="checkbox"/>	<input type="checkbox"/>	<input type="checkbox"/>		
GEO THERMAL	<input type="checkbox"/>	<input type="checkbox"/>	<input type="checkbox"/>	<input type="checkbox"/>	<input type="checkbox"/>		
OUTSIDE	<input type="checkbox"/>	<input type="checkbox"/>	<input type="checkbox"/>	<input type="checkbox"/>	<input type="checkbox"/>		
CTRL A/C	<input type="checkbox"/>	<input checked="" type="checkbox"/>	<input checked="" type="checkbox"/>	<input type="checkbox"/>	<input type="checkbox"/>		
PLUMBING	BASE						
X FULL BATH							
X HALF BATH							
X FIXTURES							

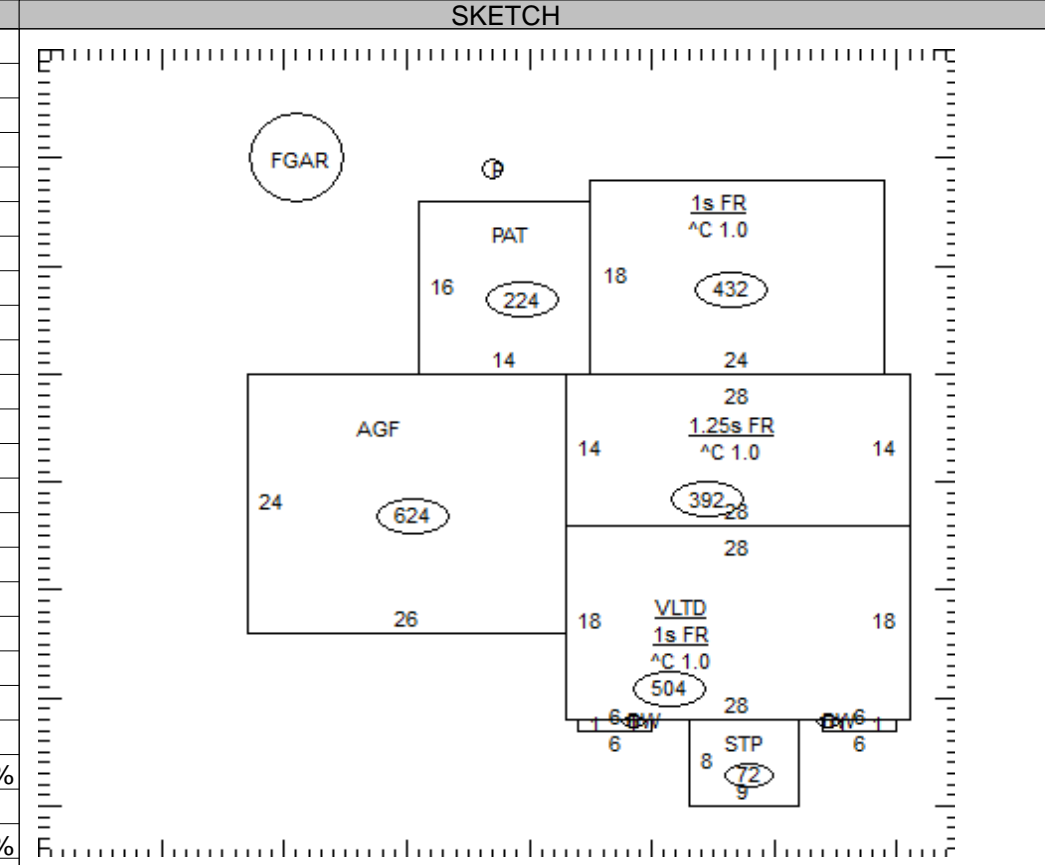

OCCUPANCY	ST.HT	SIZE	AREA	GRADE	PRICE	AGE	REMD	CND	UNADJ VAL	PHYS	PHYS VAL	FUNC	TRUE VAL
DWELLING	1.25	SK	1,426	C		1983		A	135,120	26	99,990		93,000
1 Gar - Frame		32x30	960	C	15.80	2007		A	15,170	15	12,890		12,900
2 Patio		0x0	212	C	2.70	2007		A	570	15	480		500
3													
4													
5													
6													
7													
8													
9													
10													
11													

09-065300.0000 TOTAL 106,400

COMMENTS

Dwelling has an Economic Factor of 93%