

1 OF 2		
PROP. CLASS		
5	1	0
NEIGHBORHOOD		
000730-RS20		
M	20	
B		
C	67	

07-074600.0000

**CURRY RONALD F II & SIMON CORA M**

CURRY RONALD F II & SIMON CORA M  
5600 US RTE 33  
MENDON, OH 45862

**LEGAL INFORMATION**

COMPTON ADDITION  
LOT 2

	OWNERSHIP	ADDRESS	CITY	STATE	ZIP	DATE	AMOUNT	DEED:CONV#	JS	VALID
1	CURRY RONALD F II & SIMON	5600 US RTE 33	MENDON	OH	45862	07/06/2016	69,000	5:WDC : 444	<input type="checkbox"/>	<input checked="" type="checkbox"/>
2	TOBIN DANIEL C	905 MOTZ ST	SAINT MARYS	OH	45885	12/24/2007	27,000	WDC : A-M : 887	<input type="checkbox"/>	<input type="checkbox"/>
3	FEDERAL HOME LOAN	333 W WACKER DR	CHICAGO	IL	60601	10/15/2007	25,000	SHC : S-M : 725	<input type="checkbox"/>	<input type="checkbox"/>

X:  TTO LISTER: DA DATE: 02/10/2005 TIME: 12:00:00 AM  LETTER  LETTER REC'D GIS CODE

STREET/ROAD	TOPOGRAPHY	PU-UTILITIES-PR	NEIGHBORHOOD	INFLUENCE FACTORS	PROPERTY LOCATION
5600 US RT 33 ,					
<b>COMMENT</b>					
TY2018:Net Gen=\$966.20, Other Assessment=\$2.00 DE17 ADD WDDK, COR OFF PER AERIAL DE17 DESKTOP RVW CHG: cor ex features					

LAND COMPUTATIONS						
LAND TYPE	SIZE	M	RATE	C	INF	M VALUE C
F:Front	F66 D132	ST75 DP94 ADJ71				4,700 0
TOTAL						4,700 0

VALUATION SUMMARY				
VALUE YEAR	2017	2017	2014	2011
REASON FOR CHANGE	RAPP	MISC	RAPP	RAPP
APPRAISED VALUE	LAND 4,700	4,700	4,700	4,700
	IMPR 65,000	51,800	49,900	49,900
	TOTAL 69,700	56,500	54,600	54,600
ASSESSED VALUE	LAND 1,650	1,650	1,650	1,650
	IMPR 22,750	18,130	17,470	17,470
	TOTAL 24,400	19,780	19,120	19,120

OCCUPANCY	EXTERIOR	FLOOR	AREA	CONST	VALUE										
<input checked="" type="checkbox"/> SNGL FMLY	<input type="checkbox"/> WOOD	1	892	FR	91,880										
<input type="checkbox"/> DUPLEX	<input type="checkbox"/> STUCCO	.5	336	FR	22,720										
<input type="checkbox"/> TRIPLEX	<input checked="" type="checkbox"/> ALM/VYNL														
<input type="checkbox"/> CONVR	<input type="checkbox"/> CONC BLK														
<input type="checkbox"/> MOBILE HM	<input type="checkbox"/> METAL														
<input type="checkbox"/> BI/L TRI/L	<input type="checkbox"/> BRICK														
<input type="checkbox"/> MOD/MAN	<input type="checkbox"/> STONE														
ROOFING	ROOF TYPE														
<input type="checkbox"/> METAL	<input checked="" type="checkbox"/> GABLE														
<input type="checkbox"/> SLT/TLE	<input type="checkbox"/> HIP														
<input checked="" type="checkbox"/> SHINGLES	<input type="checkbox"/> GAMBREL														
<input type="checkbox"/> SHAKES	<input type="checkbox"/> MANSARD														
<input type="checkbox"/> COMPOSITE	<input type="checkbox"/> FLAT														
		BSMT	504		6,550										
<b>SUBTOTAL</b>					<b>121,150</b>										
<b>FLOORS</b>	<b>B 1 2 3 U</b>	<b>MULTI-FAMILY #</b>	<b>0</b>		<b>0</b>										
CONCRETE	<input type="checkbox"/> <input type="checkbox"/> <input type="checkbox"/> <input type="checkbox"/> <input type="checkbox"/>	BSMT FINISH	0 S.F.		0										
WOOD	<input type="checkbox"/> <input type="checkbox"/> <input type="checkbox"/> <input type="checkbox"/> <input type="checkbox"/>	FIREPLACE #	0		0										
TILE/COMPO	<input type="checkbox"/> <input checked="" type="checkbox"/> <input type="checkbox"/> <input type="checkbox"/> <input type="checkbox"/>	HEATING	0 S.F.		0										
CARPET	<input type="checkbox"/> <input checked="" type="checkbox"/> <input checked="" type="checkbox"/> <input type="checkbox"/> <input type="checkbox"/>	AIR COND	0 S.F.		0										
<b>INT. FINISH</b>	<b>B 1 2 3 U</b>	PLUMBING #	0		0										
PLASTER/DW	<input type="checkbox"/> <input type="checkbox"/> <input type="checkbox"/> <input type="checkbox"/> <input type="checkbox"/>	GARAGES & CARPORTS			7,100										
PANELING	<input type="checkbox"/> <input checked="" type="checkbox"/> <input checked="" type="checkbox"/> <input type="checkbox"/> <input type="checkbox"/>	EXTRA FEATURES			6,900										
UNFINISHED	<input type="checkbox"/> <input type="checkbox"/> <input type="checkbox"/> <input type="checkbox"/> <input type="checkbox"/>	<b>SUBTOTAL</b>			<b>135,150</b>										
<b>ACCOMMODATIONS</b>		<b>GRADE FACTOR</b>			<b>95 %</b>										
# OF ROOMS		4	3												
BEDROOMS		1	3												
FIREPLACES															
HEAT & AC	<b>B 1 2 3 U</b>	<b>UNADJUSTED VALUE</b>			<b>128,390</b>										
NO HEAT	<input type="checkbox"/> <input type="checkbox"/> <input type="checkbox"/> <input type="checkbox"/> <input type="checkbox"/>	<b>FACTOR</b>			<b>100 %</b>										
CTRL HEAT	<input type="checkbox"/> <input checked="" type="checkbox"/> <input checked="" type="checkbox"/> <input type="checkbox"/> <input type="checkbox"/>	<b>OCCUPANCY ST.HT SIZE AREA GRADE PRICE AGE REMD CND UNADJ VAL PHYS PHYS VAL FUNC TRUE VAL</b>													
HW/STEAM	<input type="checkbox"/> <input type="checkbox"/> <input type="checkbox"/> <input type="checkbox"/> <input type="checkbox"/>	DWELLING	1.5	SK	1,228	C-		1945		A	128,390	45	70,610		65,000
ELECTRIC	<input type="checkbox"/> <input type="checkbox"/> <input type="checkbox"/> <input type="checkbox"/> <input type="checkbox"/>	1													
HEAT PUMP	<input type="checkbox"/> <input type="checkbox"/> <input type="checkbox"/> <input type="checkbox"/> <input type="checkbox"/>	2													
FLR/WALL	<input type="checkbox"/> <input type="checkbox"/> <input type="checkbox"/> <input type="checkbox"/> <input type="checkbox"/>	3													
STVE/SPCE	<input type="checkbox"/> <input type="checkbox"/> <input type="checkbox"/> <input type="checkbox"/> <input type="checkbox"/>	4													
GEO THERMAL	<input type="checkbox"/> <input type="checkbox"/> <input type="checkbox"/> <input type="checkbox"/> <input type="checkbox"/>	5													
OUTSIDE	<input type="checkbox"/> <input type="checkbox"/> <input type="checkbox"/> <input type="checkbox"/> <input type="checkbox"/>	6													
CTRL A/C	<input type="checkbox"/> <input type="checkbox"/> <input type="checkbox"/> <input type="checkbox"/> <input type="checkbox"/>	7													
PLUMBING		8													
X FULL BATH		9													
X HALF BATH		10													
X FIXTURES		11													

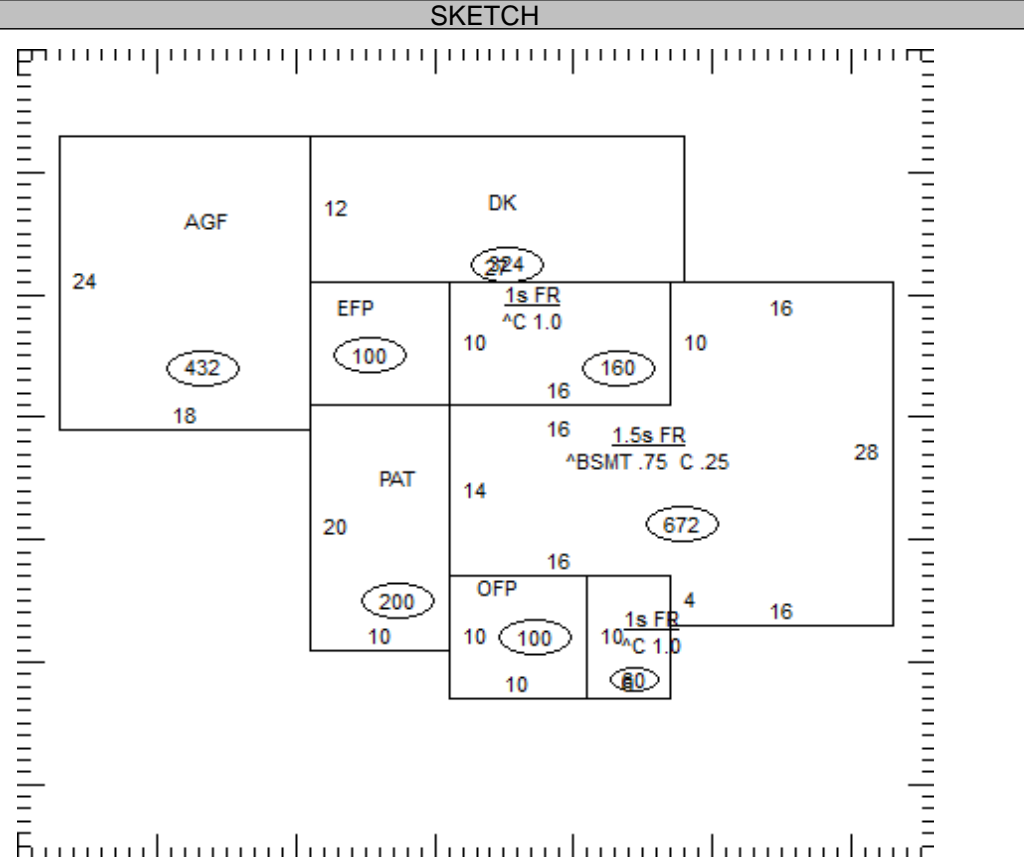

07-074600.0000

TOTAL 65,000

COMMENTS

Dwelling has an Economic Factor of 92%

PROP. CLASS		
5	1	0
NEIGHBORHOOD		
000730-RS20		
M	20	
B		
C	67	

07-074600.0000

**CURRY RONALD F II & SIMON CORA M**

CURRY RONALD F II & SIMON CORA M

5600 US RTE 33

MENDON, OH 45862

**LEGAL INFORMATION**

COMPTON ADDITION

LOT 2

OWNERSHIP	ADDRESS	CITY	STATE	ZIP	DATE	AMOUNT	DEED:CONV#	JS	VALID	
1	BEOUGHER TERRY A & MISTY	5600 US RT 33	MENDON	OH	45862	04/26/2004	55,000	WDC : A-M : 0	<input type="checkbox"/>	<input type="checkbox"/>
2	BEOUGHER JAMES ALBERT	5600 US RT 33	ROCKFORD	OH	45882	04/30/2003	0	: X : 0	<input type="checkbox"/>	<input type="checkbox"/>
3							0	0	<input type="checkbox"/>	<input type="checkbox"/>

X:  TTO LISTER: DA DATE: 02/10/2005 TIME: 12:00:00 AM  LETTER  LETTER REC'D GIS CODE

STREET/ROAD	TOPOGRAPHY	PU-UTILITIES-PR	NEIGHBORHOOD	INFLUENCE FACTORS	PROPERTY LOCATION
<input checked="" type="checkbox"/> PAVED <input type="checkbox"/> GRAVEL <input type="checkbox"/> DIRT <input type="checkbox"/> SIDEWALKS <input type="checkbox"/> CURBS	<input checked="" type="checkbox"/> LEVEL <input type="checkbox"/> HIGH <input type="checkbox"/> LOW <input type="checkbox"/> ROLLING <input type="checkbox"/> STANDARD	<input type="checkbox"/> WATER <input type="checkbox"/> SEWER <input checked="" type="checkbox"/> GAS <input checked="" type="checkbox"/> ELECTRIC <input type="checkbox"/> STANDARD	<input type="checkbox"/> IMPROVING <input checked="" type="checkbox"/> STATIC <input type="checkbox"/> DECLINING <input type="checkbox"/> OLD <input type="checkbox"/> STANDARD	<input type="checkbox"/> A. NO ROAD <input type="checkbox"/> B. TOPGRHY <input type="checkbox"/> C. Ex Front <input type="checkbox"/> D. QUANTITY <input type="checkbox"/> E. SZ/SHAPE	<input type="checkbox"/> F. RESTRICT <input type="checkbox"/> G. WOOD LT <input type="checkbox"/> H. VACANCY <input type="checkbox"/> I. WATER FRONT <input type="checkbox"/> J. OTHER/CDU

5600 US RT 33 ,  
 COMMENT

LAND COMPUTATIONS							
LAND TYPE	SIZE	M	RATE	C	INF	M	VALUE C
TOTAL							4,700 0

**VALUATION SUMMARY**

VALUE YEAR							
REASON FOR CHANGE							
APPRaised	LAND						
VALUE	IMPR						
	TOTAL						
ASSESSED	LAND						
VALUE	IMPR						
	TOTAL						

OCCUPANCY	EXTERIOR	FLOOR	AREA	CONST	VALUE
<input type="checkbox"/> SNGL FMLY	<input type="checkbox"/> WOOD				
<input type="checkbox"/> DUPLEX	<input type="checkbox"/> STUCCO				
<input type="checkbox"/> TRIPLEX	<input type="checkbox"/> ALM/VYNL				
<input type="checkbox"/> CONVR	<input type="checkbox"/> CONC BLK				
<input type="checkbox"/> MOBILE HM	<input type="checkbox"/> METAL				
<input type="checkbox"/> BI/L TRI/L	<input type="checkbox"/> BRICK				
<input type="checkbox"/> MOD/MAN	<input type="checkbox"/> STONE				

ROOFING	ROOF TYPE
<input type="checkbox"/> METAL	<input type="checkbox"/> GABLE
<input type="checkbox"/> SLT/TLE	<input type="checkbox"/> HIP
<input type="checkbox"/> SHINGLES	<input type="checkbox"/> GAMBREL
<input type="checkbox"/> SHAKES	<input type="checkbox"/> MANSARD
<input type="checkbox"/> COMPOSITE	<input type="checkbox"/> FLAT

FLOORS	B	1	2	3	U	SUBTOTAL	VALUE
CONCRETE	<input type="checkbox"/>	<input type="checkbox"/>	<input type="checkbox"/>	<input type="checkbox"/>	<input type="checkbox"/>	MULTI-FAMILY #	0
WOOD	<input type="checkbox"/>	<input type="checkbox"/>	<input type="checkbox"/>	<input type="checkbox"/>	<input type="checkbox"/>	BSMT FINISH	0 S.F.
TILE/COMPO	<input type="checkbox"/>	<input type="checkbox"/>	<input type="checkbox"/>	<input type="checkbox"/>	<input type="checkbox"/>	FIREPLACE #	0
CARPET	<input type="checkbox"/>	<input type="checkbox"/>	<input type="checkbox"/>	<input type="checkbox"/>	<input type="checkbox"/>	HEATING	0 S.F.
AIR COND						AIR COND	0 S.F.
INT. FINISH	B	1	2	3	U	PLUMBING #	0
PLASTER/DW	<input type="checkbox"/>	<input type="checkbox"/>	<input type="checkbox"/>	<input type="checkbox"/>	<input type="checkbox"/>	GARAGES & CARPORTS	0
PANELING	<input type="checkbox"/>	<input type="checkbox"/>	<input type="checkbox"/>	<input type="checkbox"/>	<input type="checkbox"/>	EXTRA FEATURES	0
UNFINISHED	<input type="checkbox"/>	<input type="checkbox"/>	<input type="checkbox"/>	<input type="checkbox"/>	<input type="checkbox"/>	SUBTOTAL	0
ACCOMMODATIONS						GRADE FACTOR	%
# OF ROOMS						UNADJUSTED VALUE	0
BEDROOMS						FACTOR	%
FIREPLACES							
HEAT & AC	B	1	2	3	U		
NO HEAT	<input type="checkbox"/>	<input type="checkbox"/>	<input type="checkbox"/>	<input type="checkbox"/>	<input type="checkbox"/>		
CTRL HEAT	<input type="checkbox"/>	<input type="checkbox"/>	<input type="checkbox"/>	<input type="checkbox"/>	<input type="checkbox"/>		
HW/STEAM	<input type="checkbox"/>	<input type="checkbox"/>	<input type="checkbox"/>	<input type="checkbox"/>	<input type="checkbox"/>		
ELECTRIC	<input type="checkbox"/>	<input type="checkbox"/>	<input type="checkbox"/>	<input type="checkbox"/>	<input type="checkbox"/>		
HEAT PUMP	<input type="checkbox"/>	<input type="checkbox"/>	<input type="checkbox"/>	<input type="checkbox"/>	<input type="checkbox"/>		
FLR/WALL	<input type="checkbox"/>	<input type="checkbox"/>	<input type="checkbox"/>	<input type="checkbox"/>	<input type="checkbox"/>		
STVE/SPCE	<input type="checkbox"/>	<input type="checkbox"/>	<input type="checkbox"/>	<input type="checkbox"/>	<input type="checkbox"/>		
GEO THERMAL	<input type="checkbox"/>	<input type="checkbox"/>	<input type="checkbox"/>	<input type="checkbox"/>	<input type="checkbox"/>		
OUTSIDE	<input type="checkbox"/>	<input type="checkbox"/>	<input type="checkbox"/>	<input type="checkbox"/>	<input type="checkbox"/>		
CTRL A/C	<input type="checkbox"/>	<input type="checkbox"/>	<input type="checkbox"/>	<input type="checkbox"/>	<input type="checkbox"/>		
PLUMBING						BASE	<input type="checkbox"/>
X FULL BATH							
X HALF BATH							
X FIXTURES							

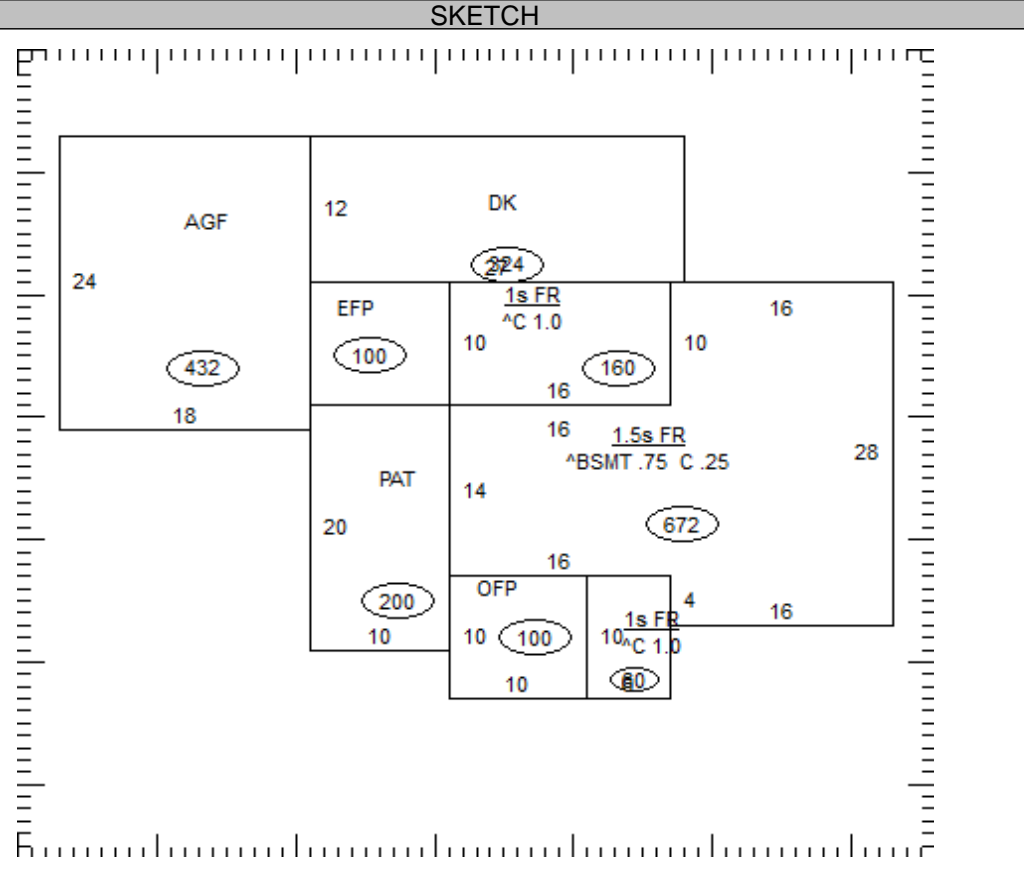

OCCUPANCY	ST.HT	SIZE	AREA	GRADE	PRICE	AGE	REMD	CND	UNADJ VAL	PHYS	PHYS VAL	FUNC	TRUE VAL
DWELLING		SK											
1													
2													
3													
4													
5													
6													
7													
8													
9													
10													
11													

07-074600.0000

TOTAL 0

COMMENTS