

06-051500.0100

PARKER GARY G & KATHY
 PARKER GARY G & KATHY

7961 HOWICK RD
 CELINA, OH 45822

Created in 2003 From 06-051500.0100 due to New

LEGAL INFORMATION
 PT S SE SE

RTS: 003-05-22
 Acres: 1.0830

OWNERSHIP	ADDRESS	CITY	STATE	ZIP	DATE	AMOUNT	DEED:CONV#	JS	VALID
1 PARKER GARY G & KATHY	7961 HOWICK RD	CELINA	OH	45822	03/18/2019	242,500	WDC : 160	<input type="checkbox"/>	<input checked="" type="checkbox"/>
2 KNOUS GARY A & JULIE E	7961 HOWICK RD	CELINA	OH	45822	07/01/2009	182,000	WDC : A : 361	<input type="checkbox"/>	<input checked="" type="checkbox"/>
3 BUDDE MARC E & LINDA S	7961 HOWICK RD	CELINA	OH	45822	11/03/2000	18,000	: A : 0	<input type="checkbox"/>	<input checked="" type="checkbox"/>

X: TTO LISTER: TWS DATE: 03/13/2017 TIME: 12:00:00 AM LETTER LETTER REC'D GIS CODE Minor Sub

STREET/ROAD	TOPOGRAPHY	PU-UTILITIES-PR	NEIGHBORHOOD	INFLUENCE FACTORS	PROPERTY LOCATION
<input checked="" type="checkbox"/> PAVED	<input checked="" type="checkbox"/> LEVEL	<input type="checkbox"/> WATER	<input type="checkbox"/> IMPROVING	<input type="checkbox"/> A. NO ROAD	7961 HOWICK RD, CELINA
<input type="checkbox"/> GRAVEL	<input type="checkbox"/> HIGH	<input type="checkbox"/> SEWER	<input type="checkbox"/> STATIC	<input type="checkbox"/> B. TOPGRHY	COMMENT TY2018:Net Gen=\$2,572.84, Other Assessment=\$2.00 DE10 ADD DET GAR DE17 FIELDCHK RVW CHGS: ADD CPY
<input type="checkbox"/> DIRT	<input type="checkbox"/> LOW	<input type="checkbox"/> GAS	<input type="checkbox"/> DECLINING	<input type="checkbox"/> C. Ex Front	
<input type="checkbox"/> SIDEWALKS	<input type="checkbox"/> ROLLING	<input type="checkbox"/> ELECTRIC	<input type="checkbox"/> OLD	<input type="checkbox"/> D. QUANTITY	
<input type="checkbox"/> CURBS	<input type="checkbox"/> STANDARD	<input checked="" type="checkbox"/> STANDARD	<input type="checkbox"/> STANDARD	<input type="checkbox"/> E. SZ/SHAPE	
				<input type="checkbox"/> F. RESTRICT	

LAND COMPUTATIONS						
LAND TYPE	SIZE	M	RATE	C	INF	M VALUE C
HS:Home Site	AC:1	16500				16,500 0
SM:Small Acreage	AC:0.083	7000				600 0
Total Acres: 1.0830						TOTAL 17,100 0

VALUATION SUMMARY

VALUE YEAR	2017	2017	2014	2013	2011	2010		
REASON FOR CHANGE	RAPP	MISC	RAPP	MISC	RAPP	NC		
APPRAISED VALUE	<u>LAND</u> 17,100	16,500	16,500	15,600	15,600	15,600		
	<u>IMPR</u> 155,300	149,000	148,100	139,700	139,700	149,400		
	<u>TOTAL</u> 172,400	165,500	164,600	155,300	155,300	165,000		
ASSESSED VALUE	<u>LAND</u> 5,990	5,780	5,780	5,460	5,460	5,460		
	<u>IMPR</u> 54,360	52,150	51,840	48,900	48,900	52,290		
	<u>TOTAL</u> 60,350	57,930	57,620	54,360	54,360	57,750		

OCCUPANCY	EXTERIOR
<input checked="" type="checkbox"/> SNGL FMLY <input type="checkbox"/> DUPLEX <input type="checkbox"/> TRIPLEX <input type="checkbox"/> CONVR <input type="checkbox"/> MOBILE HM <input type="checkbox"/> BI/L TRI/L <input type="checkbox"/> MOD/MAN	<input type="checkbox"/> WOOD <input type="checkbox"/> STUCCO <input checked="" type="checkbox"/> ALM/VYNL <input type="checkbox"/> CONC BLK <input type="checkbox"/> METAL <input type="checkbox"/> BRICK <input type="checkbox"/> STONE

ROOFING	ROOF TYPE
<input type="checkbox"/> METAL <input type="checkbox"/> SLT/TLE <input checked="" type="checkbox"/> SHINGLES <input type="checkbox"/> SHAKES <input type="checkbox"/> COMPOSITE	<input checked="" type="checkbox"/> GABLE <input type="checkbox"/> HIP <input type="checkbox"/> GAMBREL <input type="checkbox"/> MANSARD <input type="checkbox"/> FLAT

FLOORS	B	1	2	3	U
CONCRETE	<input checked="" type="checkbox"/>	<input type="checkbox"/>	<input type="checkbox"/>	<input type="checkbox"/>	<input type="checkbox"/>
WOOD	<input type="checkbox"/>	<input type="checkbox"/>	<input type="checkbox"/>	<input type="checkbox"/>	<input type="checkbox"/>
TILE/COMPO	<input type="checkbox"/>	<input checked="" type="checkbox"/>	<input checked="" type="checkbox"/>	<input type="checkbox"/>	<input type="checkbox"/>
CARPET	<input type="checkbox"/>	<input checked="" type="checkbox"/>	<input checked="" type="checkbox"/>	<input type="checkbox"/>	<input type="checkbox"/>

INT. FINISH	B	1	2	3	U
PLASTER/DW	<input type="checkbox"/>	<input checked="" type="checkbox"/>	<input checked="" type="checkbox"/>	<input type="checkbox"/>	<input type="checkbox"/>
PANELING	<input type="checkbox"/>	<input type="checkbox"/>	<input type="checkbox"/>	<input type="checkbox"/>	<input type="checkbox"/>
UNFINISHED	<input checked="" type="checkbox"/>	<input type="checkbox"/>	<input type="checkbox"/>	<input type="checkbox"/>	<input type="checkbox"/>

ACCOMMODATIONS					
# OF ROOMS	1	5	2		
BEDROOMS		1	2		
FIREPLACES					

HEAT & AC	B	1	2	3	U
NO HEAT	<input type="checkbox"/>	<input type="checkbox"/>	<input type="checkbox"/>	<input type="checkbox"/>	<input type="checkbox"/>
CTRL HEAT	<input type="checkbox"/>	<input checked="" type="checkbox"/>	<input checked="" type="checkbox"/>	<input type="checkbox"/>	<input type="checkbox"/>
HW/STEAM	<input type="checkbox"/>	<input type="checkbox"/>	<input type="checkbox"/>	<input type="checkbox"/>	<input type="checkbox"/>
ELECTRIC	<input type="checkbox"/>	<input type="checkbox"/>	<input type="checkbox"/>	<input type="checkbox"/>	<input type="checkbox"/>
HEAT PUMP	<input type="checkbox"/>	<input type="checkbox"/>	<input type="checkbox"/>	<input type="checkbox"/>	<input type="checkbox"/>
FLR/WALL	<input type="checkbox"/>	<input type="checkbox"/>	<input type="checkbox"/>	<input type="checkbox"/>	<input type="checkbox"/>
STVE/SPCE	<input type="checkbox"/>	<input type="checkbox"/>	<input type="checkbox"/>	<input type="checkbox"/>	<input type="checkbox"/>
GEOHERMAL	<input type="checkbox"/>	<input type="checkbox"/>	<input type="checkbox"/>	<input type="checkbox"/>	<input type="checkbox"/>
OUTSIDE	<input type="checkbox"/>	<input type="checkbox"/>	<input type="checkbox"/>	<input type="checkbox"/>	<input type="checkbox"/>
CTRL A/C	<input type="checkbox"/>	<input checked="" type="checkbox"/>	<input checked="" type="checkbox"/>	<input type="checkbox"/>	<input type="checkbox"/>

PLUMBING	BASE				
X FULL BATH			1		
X HALF BATH		1			
X FIXTURES					

FLOOR	AREA	CONST	VALUE
1	1428	FR	112,330
.5	644	FR	36,980
BSMT	1288		16,740
SUBTOTAL			166,050
MULTI-FAMILY #	0		0
BSMT FINISH	0 S.F.		0
FIREPLACE #	0		0
HEATING	0 S.F.		0
AIR COND	2,072 S.F.		3,110
PLUMBING #	5		5,500
GARAGES & CARPORTS			9,500
EXTRA FEATURES			4,300
SUBTOTAL			188,460
GRADE FACTOR			100 %
UNADJUSTED VALUE			188,460
FACTOR			100 %

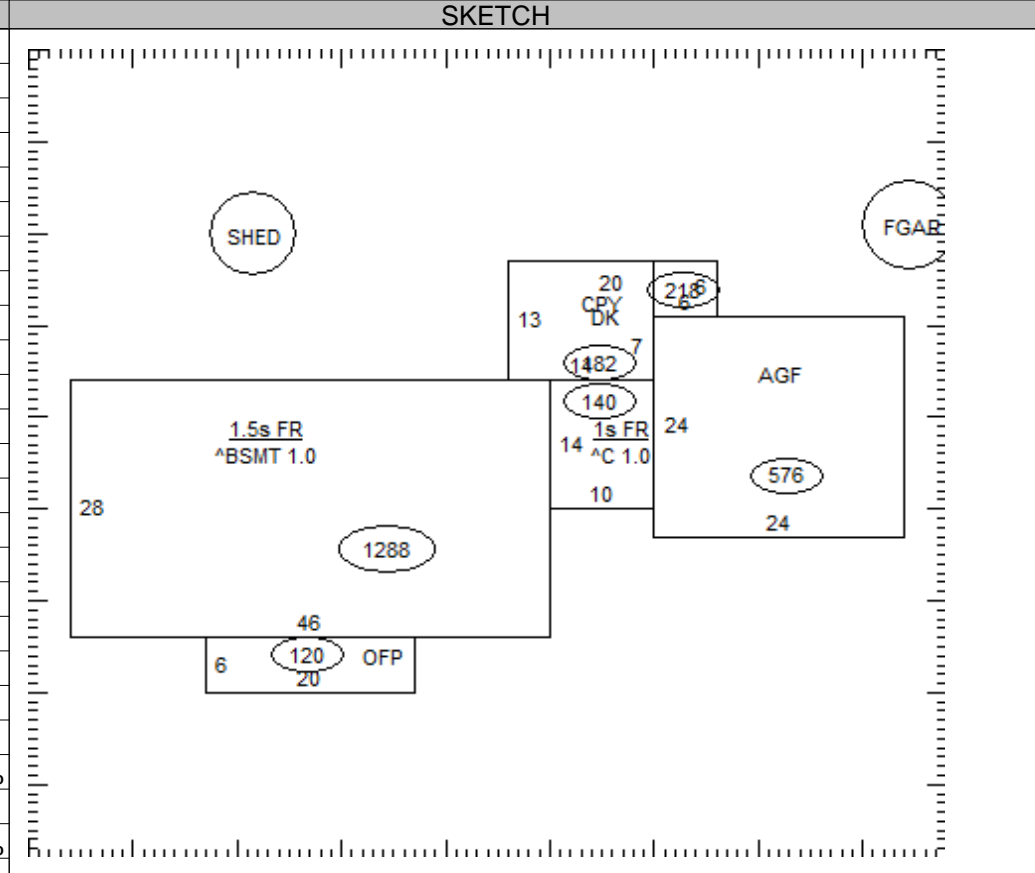

OCCUPANCY	ST.HT	SIZE	AREA	GRADE	PRICE	AGE	REMD	CND	UNADJ VAL	PHYS	PHYS VAL	FUNC	TRUE VAL
DWELLING	1.5	SK	2,072	C		2000		A	188,460	16	158,310		142,500
1 Shed		12x16	192	D	7.20	2002		A	1,380	26	1,020		1,000
2 Gar - Frame		28x30	840	C	15.80	2009		A	13,270	11	11,810		11,800
3													
4													
5													
6													
7													
8													
9													
10													
11													

06-051500.0100 TOTAL 155,300

COMMENTS

05RVL CND. CHANGED
Dwelling has an Economic Factor of 90%