

1 OF 2		
PROP. CLASS		
5	1	0
NEIGHBORHOOD		
009065-R150		
M	12	
B		
C	20A	

06-046800.0200

GINGERICH JACOB D

GINGERICH JACOB D
6819 HOWICK RD
CELINA, OH 45822

LEGAL INFORMATION

PT SW SE

RTS: 003-05-20
Acres:1.0540

	OWNERSHIP	ADDRESS	CITY	STATE	ZIP	DATE	AMOUNT	DEED:CONV#	JS	VALID
1	GINGERICH JACOB D	6819 HOWICK RD	CELINA	OH	45822	05/23/2017	27,000	WDC : 329	<input type="checkbox"/>	<input checked="" type="checkbox"/>
2	SCHWARTZ MYRON K &	6789 HOWICK RD	CELINA	OH	45822	07/23/2007	27,000	WDC : A : 511	<input type="checkbox"/>	<input type="checkbox"/>
3	LEISS BRIAN M & MELINDA S	727 SYCAMORE ST	CELINA	OH	45822	08/30/2006	25,000	WDC : A : 706	<input type="checkbox"/>	<input type="checkbox"/>

X: TTO LISTER: JK DATE: 03/12/2019 TIME: 12:00:00 AM LETTER LETTER REC'D GIS CODE

STREET/ROAD	TOPOGRAPHY	PU-UTILITIES-PR	NEIGHBORHOOD	INFLUENCE FACTORS				PROPERTY LOCATION
<input checked="" type="checkbox"/> PAVED	<input checked="" type="checkbox"/> LEVEL	<input type="checkbox"/> WATER	<input type="checkbox"/> IMPROVING	<input type="checkbox"/> A. NO ROAD	<input type="checkbox"/> F. RESTRICT	6819 HOWICK RD, CELINA		
<input type="checkbox"/> GRAVEL	<input type="checkbox"/> HIGH	<input type="checkbox"/> SEWER	<input type="checkbox"/> STATIC	<input type="checkbox"/> B. TOPGRHY	<input type="checkbox"/> G. WOOD LT	COMMENT		
<input type="checkbox"/> DIRT	<input type="checkbox"/> LOW	<input type="checkbox"/> GAS	<input type="checkbox"/> DECLINING	<input type="checkbox"/> C. Ex Front	<input type="checkbox"/> H. VACANCY	TY2018:Net Gen=\$1,564.02, Other Assessment=\$2.00 DE19 NOH; DWLG COMPL, ADD WDDK & SHED DE18 ADD DWLG AT 95% COMPL		
<input type="checkbox"/> SIDEWALKS	<input type="checkbox"/> ROLLING	<input type="checkbox"/> ELECTRIC	<input type="checkbox"/> OLD	<input type="checkbox"/> D. QUANTITY	<input type="checkbox"/> I. WATER FRONT			
<input type="checkbox"/> CURBS	<input type="checkbox"/> STANDARD	<input checked="" type="checkbox"/> STANDARD	<input type="checkbox"/> STANDARD	<input type="checkbox"/> E. SZ/SHAPE	<input type="checkbox"/> J. OTHER/CDU			

LAND COMPUTATIONS						
LAND TYPE	SIZE	M	RATE	C	INF	M VALUE C
HS:Home Site	AC:1	16500				16,500 0
SM:Small Acreage	AC:0.054	7000				400 0
Total Acres: 1.0540					TOTAL	16,900 0

VALUATION SUMMARY							
VALUE YEAR	2019	2018	2017	2014	2013	2011	
REASON FOR CHANGE	NC	NC	RAPP	RAPP	MISC	RAPP	
APPRAISED VALUE	LAND 16,900	16,900	7,200	7,600	7,200	7,100	
	IMPR 89,800	88,100	0	0	0	0	
	TOTAL 106,700	105,000	7,200	7,600	7,200	7,100	
ASSESSED VALUE	LAND 5,920	5,920	2,520	2,660	2,520	2,490	
	IMPR 31,430	30,840	0	0	0	0	
	TOTAL 37,350	36,760	2,520	2,660	2,520	2,490	

OCCUPANCY	EXTERIOR	FLOOR	AREA	CONST	VALUE
<input checked="" type="checkbox"/> SNGL FMLY	<input type="checkbox"/> WOOD	1	1392	FR	112,930
<input type="checkbox"/> DUPLEX	<input type="checkbox"/> STUCCO	.5	696	FR	41,220
<input type="checkbox"/> TRIPLEX	<input type="checkbox"/> ALM/VYNL				
<input type="checkbox"/> CONVR	<input type="checkbox"/> CONC BLK				
<input type="checkbox"/> MOBILE HM	<input checked="" type="checkbox"/> METAL				
<input type="checkbox"/> BI/L TRI/L	<input type="checkbox"/> BRICK				
<input type="checkbox"/> MOD/MAN	<input type="checkbox"/> STONE				

ROOFING	ROOF TYPE
<input checked="" type="checkbox"/> METAL	<input checked="" type="checkbox"/> GABLE
<input type="checkbox"/> SLT/TLE	<input type="checkbox"/> HIP
<input type="checkbox"/> SHINGLES	<input type="checkbox"/> GAMBREL
<input type="checkbox"/> SHAKES	<input type="checkbox"/> MANSARD
<input type="checkbox"/> COMPOSITE	<input type="checkbox"/> FLAT

FLOORS	B	1	2	3	U
CONCRETE	<input type="checkbox"/>	<input type="checkbox"/>	<input type="checkbox"/>	<input type="checkbox"/>	<input type="checkbox"/>
WOOD	<input type="checkbox"/>	<input type="checkbox"/>	<input type="checkbox"/>	<input type="checkbox"/>	<input type="checkbox"/>
TILE/COMPO	<input type="checkbox"/>	<input checked="" type="checkbox"/>	<input type="checkbox"/>	<input type="checkbox"/>	<input type="checkbox"/>
CARPET	<input type="checkbox"/>	<input checked="" type="checkbox"/>	<input type="checkbox"/>	<input type="checkbox"/>	<input type="checkbox"/>

INT. FINISH	B	1	2	3	U
PLASTER/DW	<input type="checkbox"/>	<input checked="" type="checkbox"/>	<input type="checkbox"/>	<input type="checkbox"/>	<input type="checkbox"/>
PANELING	<input type="checkbox"/>	<input type="checkbox"/>	<input type="checkbox"/>	<input type="checkbox"/>	<input type="checkbox"/>
UNFINISHED	<input type="checkbox"/>	<input type="checkbox"/>	<input type="checkbox"/>	<input type="checkbox"/>	<input type="checkbox"/>

ACCOMMODATIONS	
# OF ROOMS	3
BEDROOMS	1
FIREPLACES	
HEAT & AC	<input checked="" type="checkbox"/>

NO HEAT	CTRL HEAT	HW/STEAM	ELECTRIC	HEAT PUMP	FLR/WALL	STVE/SPCE	GEO THERMAL	OUTSIDE	CTRL A/C
<input type="checkbox"/>	<input type="checkbox"/>	<input checked="" type="checkbox"/>	<input type="checkbox"/>	<input type="checkbox"/>	<input type="checkbox"/>	<input type="checkbox"/>	<input type="checkbox"/>	<input type="checkbox"/>	<input type="checkbox"/>
<input type="checkbox"/>	<input type="checkbox"/>	<input type="checkbox"/>	<input type="checkbox"/>	<input type="checkbox"/>	<input type="checkbox"/>	<input type="checkbox"/>	<input type="checkbox"/>	<input type="checkbox"/>	<input type="checkbox"/>
<input type="checkbox"/>	<input type="checkbox"/>	<input type="checkbox"/>	<input type="checkbox"/>	<input type="checkbox"/>	<input type="checkbox"/>	<input type="checkbox"/>	<input type="checkbox"/>	<input type="checkbox"/>	<input type="checkbox"/>
<input type="checkbox"/>	<input type="checkbox"/>	<input type="checkbox"/>	<input type="checkbox"/>	<input type="checkbox"/>	<input type="checkbox"/>	<input type="checkbox"/>	<input type="checkbox"/>	<input type="checkbox"/>	<input type="checkbox"/>
<input type="checkbox"/>	<input type="checkbox"/>	<input type="checkbox"/>	<input type="checkbox"/>	<input type="checkbox"/>	<input type="checkbox"/>	<input type="checkbox"/>	<input type="checkbox"/>	<input type="checkbox"/>	<input type="checkbox"/>
<input type="checkbox"/>	<input type="checkbox"/>	<input type="checkbox"/>	<input type="checkbox"/>	<input type="checkbox"/>	<input type="checkbox"/>	<input type="checkbox"/>	<input type="checkbox"/>	<input type="checkbox"/>	<input type="checkbox"/>
<input type="checkbox"/>	<input type="checkbox"/>	<input type="checkbox"/>	<input type="checkbox"/>	<input type="checkbox"/>	<input type="checkbox"/>	<input type="checkbox"/>	<input type="checkbox"/>	<input type="checkbox"/>	<input type="checkbox"/>
<input type="checkbox"/>	<input type="checkbox"/>	<input checked="" type="checkbox"/>	<input type="checkbox"/>	<input type="checkbox"/>	<input type="checkbox"/>	<input type="checkbox"/>	<input type="checkbox"/>	<input type="checkbox"/>	<input type="checkbox"/>

PLUMBING	BASE
X FULL BATH	1
X HALF BATH	
X FIXTURES	

SUBTOTAL	VALUE
SUBTOTAL	154,150
MULTI-FAMILY #	0
BSMT FINISH	0 S.F.
FIREPLACE #	0
HEATING	0 S.F.
AIR COND	1,392 S.F.
PLUMBING #	3
GARAGES & CARPORTS	8,700
EXTRA FEATURES	3,200
SUBTOTAL	171,440
GRADE FACTOR	60 %
UNADJUSTED VALUE	102,860
FACTOR	100 %

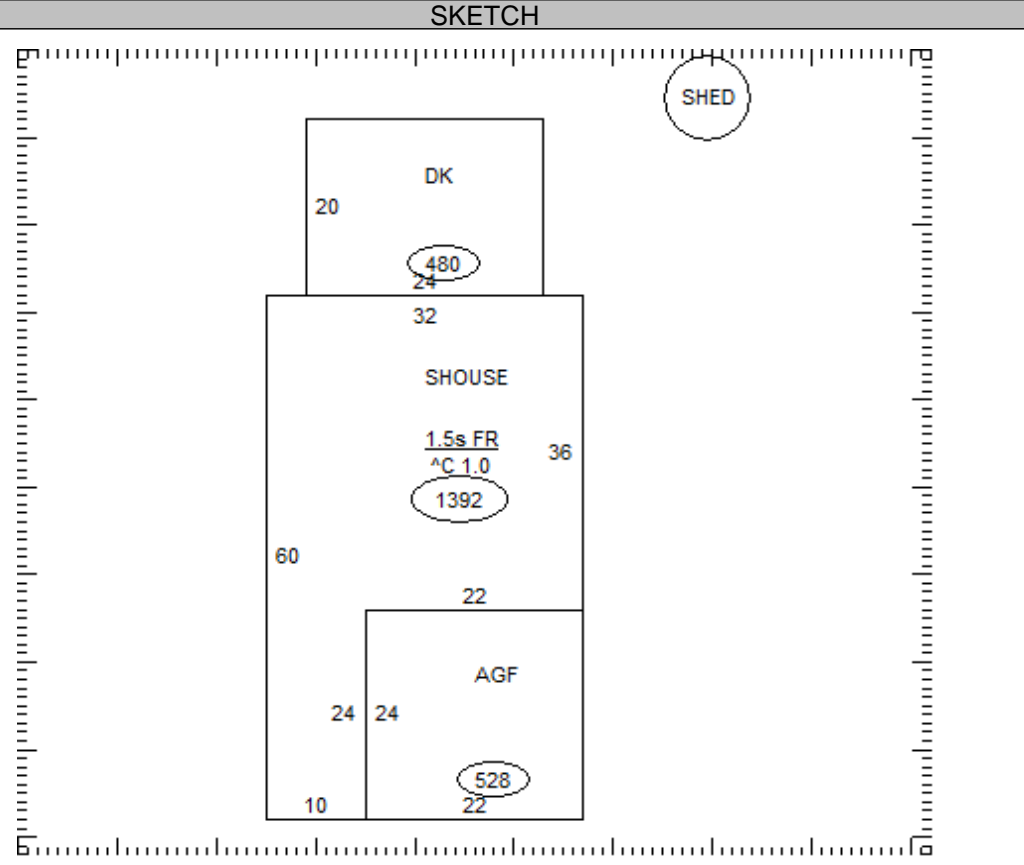

OCCUPANCY	ST.HT	SIZE	AREA	GRADE	PRICE	AGE	REMD	CND	UNADJ VAL	PHYS	PHYS VAL	FUNC	TRUE VAL
DWELLING	1.5	SK	2,088	E+		2017		A	102,860	3	99,770		89,800
1 Shed		8x12	96	C		2018		A		2			0
2													
3													
4													
5													
6													
7													
8													
9													
10													
11													

06-046800.0200	TOTAL	89,800
----------------	-------	--------

COMMENTS
 Dwelling has an Economic Factor of 90%

2 OF 2		
PROP. CLASS		
5	1	0
NEIGHBORHOOD		
009065-R150		
M	12	
B		
C	20A	

CENTER TWP / CELINA SD

06-20-400-010

06-046800.0200

LEGAL INFORMATION
PT SW SE

RTS: 003-05-20
Acres:1.0540

GINGERICH JACOB D
GINGERICH JACOB D
6819 HOWICK RD
CELINA, OH 45822

	OWNERSHIP	ADDRESS	CITY	STATE	ZIP	DATE	AMOUNT	DEED:CONV#	JS	VALID
1	BERTKE DONALD J &	1025 HEMLOCK ST	CELINA	OH	45822		0	:0	<input type="checkbox"/>	<input type="checkbox"/>
2							0	0	<input type="checkbox"/>	<input type="checkbox"/>
3							0	0	<input type="checkbox"/>	<input type="checkbox"/>

X: TTO LISTER: JK DATE: 03/12/2019 TIME: 12:00:00 AM LETTER LETTER REC'D GIS CODE

STREET/ROAD	TOPOGRAPHY	PU-UTILITIES-PR	NEIGHBORHOOD	INFLUENCE FACTORS	PROPERTY LOCATION
<input checked="" type="checkbox"/> PAVED	<input checked="" type="checkbox"/> LEVEL	<input type="checkbox"/> WATER <input type="checkbox"/>	<input type="checkbox"/> IMPROVING	<input type="checkbox"/> A. NO ROAD <input type="checkbox"/> F. RESTRICT	6819 HOWICK RD, CELINA
<input type="checkbox"/> GRAVEL	<input type="checkbox"/> HIGH	<input type="checkbox"/> SEWER <input type="checkbox"/>	<input type="checkbox"/> STATIC	<input type="checkbox"/> B. TOPGRHY <input type="checkbox"/> G. WOOD LT	COMMENT
<input type="checkbox"/> DIRT	<input type="checkbox"/> LOW	<input type="checkbox"/> GAS <input type="checkbox"/>	<input type="checkbox"/> DECLINING	<input type="checkbox"/> C. Ex Front <input type="checkbox"/> H. VACANCY	
<input type="checkbox"/> SIDEWALKS	<input type="checkbox"/> ROLLING	<input type="checkbox"/> ELECTRIC <input type="checkbox"/>	<input type="checkbox"/> OLD	<input type="checkbox"/> D. QUANTITY <input type="checkbox"/> I. WATER FRONT	
<input type="checkbox"/> CURBS	<input type="checkbox"/> STANDARD	<input checked="" type="checkbox"/> STANDARD	<input type="checkbox"/> STANDARD	<input type="checkbox"/> E. SZ/SHAPE <input type="checkbox"/> J. OTHER/CDU	

LAND COMPUTATIONS							
LAND TYPE	SIZE	M	RATE	C	INF	M	VALUE C
Total Acres: 1.0540					TOTAL		16,900 0

VALUATION SUMMARY

VALUE YEAR	REASON FOR CHANGE	APPRaised	LAND	IMPR	TOTAL	ASSESSED	LAND	IMPR	TOTAL

OCCUPANCY	EXTERIOR
<input type="checkbox"/> SNGL FMLY	<input type="checkbox"/> WOOD
<input type="checkbox"/> DUPLEX	<input type="checkbox"/> STUCCO
<input type="checkbox"/> TRIPLEX	<input type="checkbox"/> ALM/VYNL
<input type="checkbox"/> CONVR	<input type="checkbox"/> CONC BLK
<input type="checkbox"/> MOBILE HM	<input type="checkbox"/> METAL
<input type="checkbox"/> BI/L TRI/L	<input type="checkbox"/> BRICK
<input type="checkbox"/> MOD/MAN	<input type="checkbox"/> STONE

ROOFING	ROOF TYPE
<input type="checkbox"/> METAL	<input type="checkbox"/> GABLE
<input type="checkbox"/> SLT/TLE	<input type="checkbox"/> HIP
<input type="checkbox"/> SHINGLES	<input type="checkbox"/> GAMBREL
<input type="checkbox"/> SHAKES	<input type="checkbox"/> MANSARD
<input type="checkbox"/> COMPOSITE	<input type="checkbox"/> FLAT

FLOORS	B	1	2	3	U
CONCRETE	<input type="checkbox"/>	<input type="checkbox"/>	<input type="checkbox"/>	<input type="checkbox"/>	<input type="checkbox"/>
WOOD	<input type="checkbox"/>	<input type="checkbox"/>	<input type="checkbox"/>	<input type="checkbox"/>	<input type="checkbox"/>
TILE/COMPO	<input type="checkbox"/>	<input type="checkbox"/>	<input type="checkbox"/>	<input type="checkbox"/>	<input type="checkbox"/>
CARPET	<input type="checkbox"/>	<input type="checkbox"/>	<input type="checkbox"/>	<input type="checkbox"/>	<input type="checkbox"/>

INT. FINISH	B	1	2	3	U
PLASTER/DW	<input type="checkbox"/>	<input type="checkbox"/>	<input type="checkbox"/>	<input type="checkbox"/>	<input type="checkbox"/>
PANELING	<input type="checkbox"/>	<input type="checkbox"/>	<input type="checkbox"/>	<input type="checkbox"/>	<input type="checkbox"/>
UNFINISHED	<input type="checkbox"/>	<input type="checkbox"/>	<input type="checkbox"/>	<input type="checkbox"/>	<input type="checkbox"/>

ACCOMMODATIONS					
# OF ROOMS					
BEDROOMS					
FIREPLACES					
HEAT & AC	B	1	2	3	U

NO HEAT	<input type="checkbox"/>	<input type="checkbox"/>	<input type="checkbox"/>	<input type="checkbox"/>	<input type="checkbox"/>
CTRL HEAT	<input type="checkbox"/>	<input type="checkbox"/>	<input type="checkbox"/>	<input type="checkbox"/>	<input type="checkbox"/>
HW/STEAM	<input type="checkbox"/>	<input type="checkbox"/>	<input type="checkbox"/>	<input type="checkbox"/>	<input type="checkbox"/>
ELECTRIC	<input type="checkbox"/>	<input type="checkbox"/>	<input type="checkbox"/>	<input type="checkbox"/>	<input type="checkbox"/>
HEAT PUMP	<input type="checkbox"/>	<input type="checkbox"/>	<input type="checkbox"/>	<input type="checkbox"/>	<input type="checkbox"/>
FLR/WALL	<input type="checkbox"/>	<input type="checkbox"/>	<input type="checkbox"/>	<input type="checkbox"/>	<input type="checkbox"/>
STVE/SPCE	<input type="checkbox"/>	<input type="checkbox"/>	<input type="checkbox"/>	<input type="checkbox"/>	<input type="checkbox"/>
GEO THERMAL	<input type="checkbox"/>	<input type="checkbox"/>	<input type="checkbox"/>	<input type="checkbox"/>	<input type="checkbox"/>
OUTSIDE	<input type="checkbox"/>	<input type="checkbox"/>	<input type="checkbox"/>	<input type="checkbox"/>	<input type="checkbox"/>
CTRL A/C	<input type="checkbox"/>	<input type="checkbox"/>	<input type="checkbox"/>	<input type="checkbox"/>	<input type="checkbox"/>
PLUMBING		BASE	<input type="checkbox"/>		
X FULL BATH					
X HALF BATH					
X FIXTURES					

FLOOR	AREA	CONST	VALUE

SUBTOTAL			0
MULTI-FAMILY #	0		0
BSMT FINISH	0 S.F.		0
FIREPLACE #	0		0
HEATING	0 S.F.		0
AIR COND	0 S.F.		0
PLUMBING #	0		0
GARAGES & CARPORTS			0
EXTRA FEATURES			0
SUBTOTAL			0
GRADE FACTOR			%
UNADJUSTED VALUE			0
FACTOR			%

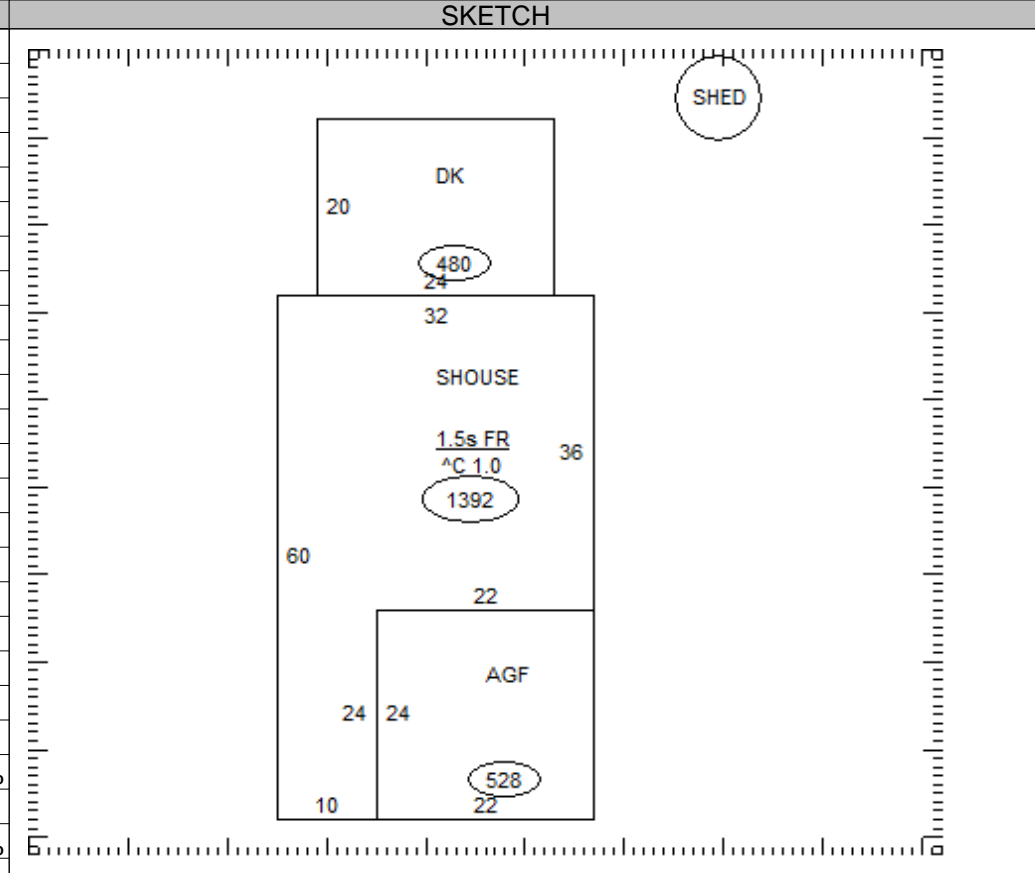

OCCUPANCY	ST.HT	SIZE	AREA	GRADE	PRICE	AGE	REMD	CND	UNADJ VAL	PHYS	PHYS VAL	FUNC	TRUE VAL
DWELLING		SK											
1													
2													
3													
4													
5													
6													
7													
8													
9													
10													
11													

06-046800.0200

TOTAL 0

COMMENTS