

1 OF 2		
PROP. CLASS		
1	1	1
NEIGHBORHOOD		
009061-A100		
M	09	
B		
C	02	

06-020700.0000

T & S GARWOOD FARMS LLC

T & S GARWOOD FARMS LLC

9385 ST RTE 197

CELINA, OH 45822

LEGAL INFORMATION

W 1/2 NE

RTS: 003-05-12
Acres:80.0000

**QUALIFIED CREDITS: CAUV:
06389: 2018**

	OWNERSHIP	ADDRESS	CITY	STATE	ZIP	DATE	AMOUNT	DEED:CONV#	JS	VALID
1	T & S GARWOOD FARMS LLC	9385 ST RTE 197	CELINA	OH	45822	12/05/2017	664,000	WDC : 838	<input type="checkbox"/>	<input checked="" type="checkbox"/>
2	WHARTON CHARLES	10620 NEPTUNE MENDON RD	MENDON	OH	45862	01/01/1900	0	: 0	<input type="checkbox"/>	<input type="checkbox"/>
3							0	0	<input type="checkbox"/>	<input type="checkbox"/>

X: TTO LISTER: JK DATE: 03/12/2019 TIME: 12:00:00 AM LETTER LETTER REC'D GIS CODE

STREET/ROAD	TOPOGRAPHY	PU-UTILITIES-PR	NEIGHBORHOOD	INFLUENCE FACTORS	PROPERTY LOCATION
<input checked="" type="checkbox"/> PAVED	<input checked="" type="checkbox"/> LEVEL	<input type="checkbox"/> WATER	<input type="checkbox"/> IMPROVING	<input type="checkbox"/> A. NO ROAD	0 ST RT 197 , CELINA
<input type="checkbox"/> GRAVEL	<input type="checkbox"/> HIGH	<input type="checkbox"/> SEWER	<input type="checkbox"/> STATIC	<input type="checkbox"/> F. RESTRICT	COMMENT TY2018:Net Gen=\$3,404.56, Other Assessment=\$2,401.22 NC20 CHK FOR RMVL OF DWLG DE19 NOH; RMV ALL BDLS, DWLG STILL HERE DE17 FIELDCHK RVW CHGS: DE18 TTO; DWLG VAC DE18 REMOVE OWN OCC didn't return app
<input type="checkbox"/> DIRT	<input type="checkbox"/> LOW	<input type="checkbox"/> GAS	<input type="checkbox"/> DECLINING	<input type="checkbox"/> B. TOPGRHY	
<input type="checkbox"/> SIDEWALKS	<input type="checkbox"/> ROLLING	<input type="checkbox"/> ELECTRIC	<input type="checkbox"/> OLD	<input type="checkbox"/> C. Ex Front	
<input type="checkbox"/> CURBS	<input type="checkbox"/> STANDARD	<input checked="" type="checkbox"/> STANDARD	<input type="checkbox"/> STANDARD	<input type="checkbox"/> D. QUANTITY	
				<input type="checkbox"/> E. SZ/SHAPE	
				<input type="checkbox"/> G. WOOD LT	
				<input type="checkbox"/> H. VACANCY	
				<input type="checkbox"/> I. WATER FRONT	
				<input type="checkbox"/> J. OTHER/CDU	

LAND COMPUTATIONS							
LAND TYPE	SIZE	M	RATE	C	INF	M	VALUE C
CR:Crop Land TOTAL	A 58.0000		8,907	2,475		527,500	156,650
0069	A 19.1000		8,790	2,280		167,890	43,550
0070	A 8.9000		8,450	1,955		75,210	17,400
0087	A 30.0000		9,480	3,190		284,400	95,700
HS:Home Site:0601	A 1.0000		16,500	16,500		16,500	16,500
RD:Road:0900	A .5000		0	0		0	0
WO:Woods TOTAL	A 20.0000		4,580	765		90,190	13,050
0069	A 14.8000		4,420	545		65,420	8,070
0070	A 2.2000		3,990	345		8,780	760
Total Acres: 80.0000					TOTAL	634,240	186,230

VALUATION SUMMARY								
VALUE YEAR	2019	2019	2018	2018	2017	2017	2017	2017
REASON FOR CHANGE	CAUV	REMB	CAUV	REMB	CAUV	RAPP	CAUV	MISC
APPRAISED	186,230	634,240	186,230	634,240	186,230	634,240	260,590	567,410
VALUE								
LAND	186,230	634,240	186,230	634,240	186,230	634,240	260,590	567,410
IMPR	35,600	35,600	36,400	36,400	48,300	48,300	42,100	42,100
TOTAL	221,830	669,840	222,630	670,640	234,530	682,540	302,690	609,510
ASSESSED	65,180	221,980	65,180	221,980	65,180	221,980	91,210	198,590
VALUE								
LAND	65,180	221,980	65,180	221,980	65,180	221,980	91,210	198,590
IMPR	12,460	12,460	12,740	12,740	16,910	16,910	14,740	14,740
TOTAL	77,640	234,440	77,920	234,720	82,090	238,890	105,950	213,330
CAUV TAX SAVINGS	2018=6851.06, 2017=6852.20, 2016=4588.36: Total=18291.62							

OCCUPANCY	EXTERIOR	FLOOR	AREA	CONST	VALUE
<input checked="" type="checkbox"/> SINGL FMLY	<input checked="" type="checkbox"/> WOOD	1	1630	FR	121,780
<input type="checkbox"/> DUPLEX	<input type="checkbox"/> STUCCO	.5	384	FR	20,940
<input type="checkbox"/> TRIPLEX	<input type="checkbox"/> ALM/VYNL				
<input type="checkbox"/> CONVR	<input type="checkbox"/> CONC BLK				
<input type="checkbox"/> MOBILE HM	<input type="checkbox"/> METAL				
<input type="checkbox"/> BI/L TRI/L	<input type="checkbox"/> BRICK				
<input type="checkbox"/> MOD/MAN	<input type="checkbox"/> STONE				

ROOFING	ROOF TYPE
<input type="checkbox"/> METAL	<input type="checkbox"/> GABLE
<input type="checkbox"/> SLT/TLE	<input type="checkbox"/> HIP
<input checked="" type="checkbox"/> SHINGLES	<input type="checkbox"/> GAMBREL
<input type="checkbox"/> SHAKES	<input type="checkbox"/> MANSARD
<input type="checkbox"/> COMPOSITE	<input type="checkbox"/> FLAT

BSMT	192	2,500
SUBTOTAL		145,220
FLOORS	B 1 2 3 U	
CONCRETE	<input type="checkbox"/> <input type="checkbox"/> <input type="checkbox"/> <input type="checkbox"/> <input type="checkbox"/>	
WOOD	<input type="checkbox"/> <input checked="" type="checkbox"/> <input checked="" type="checkbox"/> <input type="checkbox"/> <input type="checkbox"/>	
TILE/COMPO	<input type="checkbox"/> <input type="checkbox"/> <input type="checkbox"/> <input type="checkbox"/> <input type="checkbox"/>	
CARPET	<input type="checkbox"/> <input type="checkbox"/> <input type="checkbox"/> <input type="checkbox"/> <input type="checkbox"/>	
INT. FINISH	B 1 2 3 U	
PLASTER/DW	<input type="checkbox"/> <input checked="" type="checkbox"/> <input checked="" type="checkbox"/> <input type="checkbox"/> <input type="checkbox"/>	
PANELING	<input type="checkbox"/> <input type="checkbox"/> <input type="checkbox"/> <input type="checkbox"/> <input type="checkbox"/>	
UNFINISHED	<input type="checkbox"/> <input type="checkbox"/> <input type="checkbox"/> <input type="checkbox"/> <input type="checkbox"/>	
ACCOMMODATIONS		
# OF ROOMS	4 3	
BEDROOMS	1 3	
FIREPLACES		
HEAT & AC	B 1 2 3 U	
NO HEAT	<input type="checkbox"/> <input type="checkbox"/> <input type="checkbox"/> <input type="checkbox"/> <input type="checkbox"/>	
CTRL HEAT	<input type="checkbox"/> <input checked="" type="checkbox"/> <input checked="" type="checkbox"/> <input type="checkbox"/> <input type="checkbox"/>	
HW/STEAM	<input type="checkbox"/> <input type="checkbox"/> <input type="checkbox"/> <input type="checkbox"/> <input type="checkbox"/>	
ELECTRIC	<input type="checkbox"/> <input type="checkbox"/> <input type="checkbox"/> <input type="checkbox"/> <input type="checkbox"/>	
HEAT PUMP	<input type="checkbox"/> <input type="checkbox"/> <input type="checkbox"/> <input type="checkbox"/> <input type="checkbox"/>	
FLR/WALL	<input type="checkbox"/> <input type="checkbox"/> <input type="checkbox"/> <input type="checkbox"/> <input type="checkbox"/>	
STVE/SPCE	<input type="checkbox"/> <input type="checkbox"/> <input type="checkbox"/> <input type="checkbox"/> <input type="checkbox"/>	
GEOTHERMAL	<input type="checkbox"/> <input type="checkbox"/> <input type="checkbox"/> <input type="checkbox"/> <input type="checkbox"/>	
OUTSIDE	<input type="checkbox"/> <input type="checkbox"/> <input type="checkbox"/> <input type="checkbox"/> <input type="checkbox"/>	
CTRL A/C	<input type="checkbox"/> <input type="checkbox"/> <input type="checkbox"/> <input type="checkbox"/> <input type="checkbox"/>	
PLUMBING	BASE <input checked="" type="checkbox"/>	
X FULL BATH		
X HALF BATH		
X FIXTURES		

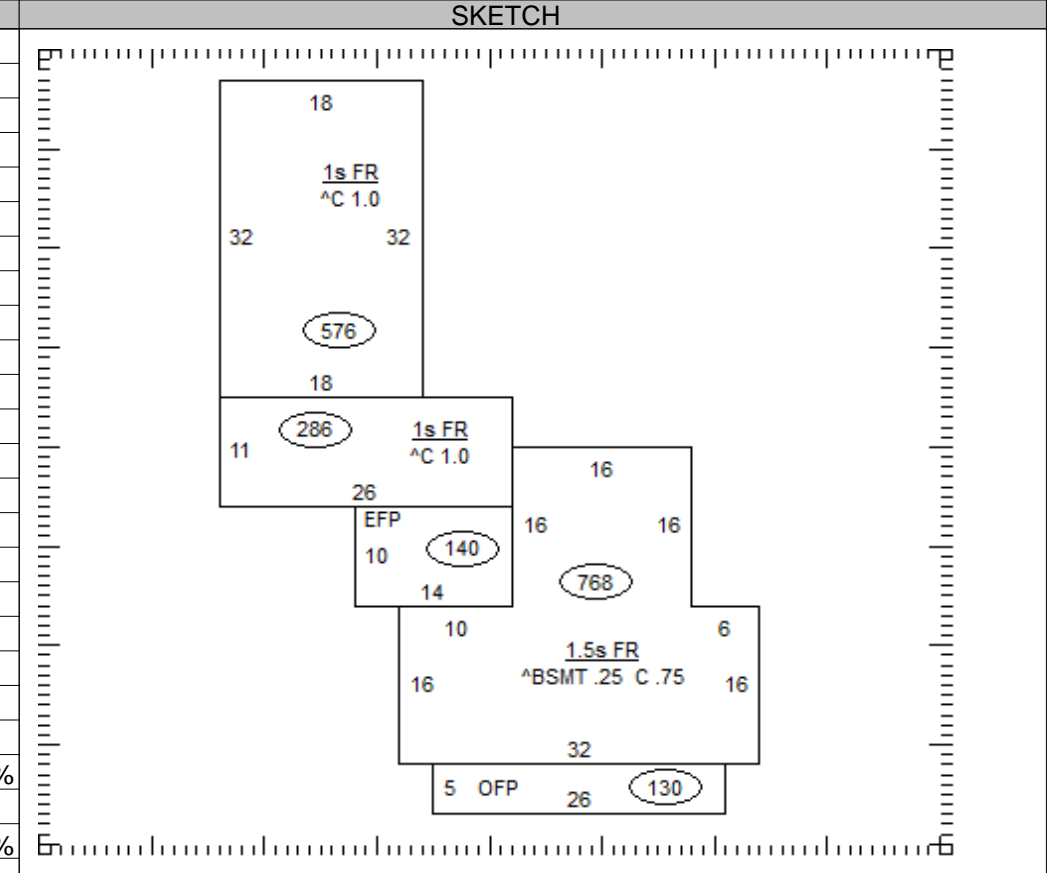

OCCUPANCY	ST.HT	SIZE	AREA	GRADE	PRICE	AGE	REMD	CND	UNADJ VAL	PHYS	PHYS VAL	FUNC	TRUE VAL
DWELLING	1.5	SK	2,014	C		1896		P	150,820	65	52,790	VAC25	35,600
1													
2													
3													
4													
5													
6													
7													
8													
9													
10													
11													

06-020700.0000 TOTAL 35,600

COMMENTS

Dwelling has an Economic Factor of 90%

CENTER TWP / CELINA SD

06-12-200-001

06-020700.0000

T & S GARWOOD FARMS LLC

T & S GARWOOD FARMS LLC

9385 ST RTE 197

CELINA, OH 45822

LEGAL INFORMATION

W 1/2 NE

RTS: 003-05-12
 Acres:80.0000

**QUALIFIED CREDITS: CAUV:
 06389: 2018**

	OWNERSHIP	ADDRESS	CITY	STATE	ZIP	DATE	AMOUNT	DEED:CONV#	JS	VALID
1	T & S GARWOOD FARMS LLC	9385 ST RTE 197	CELINA	OH	45822	12/05/2017	664,000	WDC : 838	<input type="checkbox"/>	<input checked="" type="checkbox"/>
2	WHARTON CHARLES	10620 NEPTUNE MENDON RD	MENDON	OH	45862	01/01/1900	0	: 0	<input type="checkbox"/>	<input type="checkbox"/>
3							0	0	<input type="checkbox"/>	<input type="checkbox"/>

X: TTO LISTER: JK DATE: 03/12/2019 TIME: 12:00:00 AM LETTER LETTER REC'D GIS CODE

STREET/ROAD	TOPOGRAPHY	PU-UTILITIES-PR	NEIGHBORHOOD	INFLUENCE FACTORS	PROPERTY LOCATION
<input checked="" type="checkbox"/> PAVED	<input checked="" type="checkbox"/> LEVEL	<input type="checkbox"/> WATER <input type="checkbox"/>	<input type="checkbox"/> IMPROVING	<input type="checkbox"/> A. NO ROAD <input type="checkbox"/> F. RESTRICT	0 ST RT 197 , CELINA
<input type="checkbox"/> GRAVEL	<input type="checkbox"/> HIGH	<input type="checkbox"/> SEWER <input type="checkbox"/>	<input type="checkbox"/> STATIC	<input type="checkbox"/> B. TOPGRHY <input type="checkbox"/> G. WOOD LT	COMMENT
<input type="checkbox"/> DIRT	<input type="checkbox"/> LOW	<input type="checkbox"/> GAS <input type="checkbox"/>	<input type="checkbox"/> DECLINING	<input type="checkbox"/> C. Ex Front <input type="checkbox"/> H. VACANCY	
<input type="checkbox"/> SIDEWALKS	<input type="checkbox"/> ROLLING	<input type="checkbox"/> ELECTRIC <input type="checkbox"/>	<input type="checkbox"/> OLD	<input type="checkbox"/> D. QUANTITY <input type="checkbox"/> I. WATER FRONT	
<input type="checkbox"/> CURBS	<input type="checkbox"/> STANDARD	<input checked="" type="checkbox"/> STANDARD	<input type="checkbox"/> STANDARD	<input type="checkbox"/> E. SZ/SHAPE <input type="checkbox"/> J. OTHER/CDU	

LAND COMPUTATIONS

LAND TYPE	SIZE	M	RATE	C	INF	M	VALUE	C
0087	A 3.0000		5,330	1,405			15,990	4,220
WS:Waste:0990	A .5000		100	50			50	30
Total Acres: 80.0000					TOTAL		634,240	186,230

VALUATION SUMMARY

VALUE YEAR	2014	2014	2011	2011			
REASON FOR CHANGE	CAUV	RAPP	CAUV	RAPP			
APPRAISED	260,590	567,410	111,690	381,310			
VALUE	LAND						
	IMPR	34,300	34,300	34,200	34,200		
	TOTAL	294,890	601,710	145,890	415,510		
ASSESSED	LAND	91,210	198,590	39,090	133,460		
VALUE	IMPR	12,010	12,010	11,970	11,970		
	TOTAL	103,220	210,600	51,060	145,430		
CAUV TAX SAVINGS	2018=6851.06, 2017=6852.20, 2016=4588.36: Total=18291.62						

OCCUPANCY	EXTERIOR	FLOOR	AREA	CONST	VALUE
<input type="checkbox"/> SNGL FMLY	<input type="checkbox"/> WOOD				
<input type="checkbox"/> DUPLEX	<input type="checkbox"/> STUCCO				
<input type="checkbox"/> TRIPLEX	<input type="checkbox"/> ALM/VYNL				
<input type="checkbox"/> CONVR	<input type="checkbox"/> CONC BLK				
<input type="checkbox"/> MOBILE HM	<input type="checkbox"/> METAL				
<input type="checkbox"/> BI/L TRI/L	<input type="checkbox"/> BRICK				
<input type="checkbox"/> MOD/MAN	<input type="checkbox"/> STONE				

ROOFING	ROOF TYPE
<input type="checkbox"/> METAL	<input type="checkbox"/> GABLE
<input type="checkbox"/> SLT/TLE	<input type="checkbox"/> HIP
<input type="checkbox"/> SHINGLES	<input type="checkbox"/> GAMBREL
<input type="checkbox"/> SHAKES	<input type="checkbox"/> MANSARD
<input type="checkbox"/> COMPOSITE	<input type="checkbox"/> FLAT

FLOORS	B	1	2	3	U		VALUE
CONCRETE	<input type="checkbox"/>	<input type="checkbox"/>	<input type="checkbox"/>	<input type="checkbox"/>	<input type="checkbox"/>	MULTI-FAMILY #	0
WOOD	<input type="checkbox"/>	<input type="checkbox"/>	<input type="checkbox"/>	<input type="checkbox"/>	<input type="checkbox"/>	BSMT FINISH	0 S.F.
TILE/COMPO	<input type="checkbox"/>	<input type="checkbox"/>	<input type="checkbox"/>	<input type="checkbox"/>	<input type="checkbox"/>	FIREPLACE #	0
CARPET	<input type="checkbox"/>	<input type="checkbox"/>	<input type="checkbox"/>	<input type="checkbox"/>	<input type="checkbox"/>	HEATING	0 S.F.
						AIR COND	0 S.F.
						PLUMBING #	0
						GARAGES & CARPORTS	0
						EXTRA FEATURES	0
						SUBTOTAL	0
						GRADE FACTOR	%
						UNADJUSTED VALUE	0
						FACTOR	%

INT. FINISH	B	1	2	3	U		VALUE
PLASTER/DW	<input type="checkbox"/>	<input type="checkbox"/>	<input type="checkbox"/>	<input type="checkbox"/>	<input type="checkbox"/>		
PANELING	<input type="checkbox"/>	<input type="checkbox"/>	<input type="checkbox"/>	<input type="checkbox"/>	<input type="checkbox"/>		
UNFINISHED	<input type="checkbox"/>	<input type="checkbox"/>	<input type="checkbox"/>	<input type="checkbox"/>	<input type="checkbox"/>		
ACCOMMODATIONS							
# OF ROOMS							
BEDROOMS							
FIREPLACES							
HEAT & AC	B	1	2	3	U		
NO HEAT	<input type="checkbox"/>	<input type="checkbox"/>	<input type="checkbox"/>	<input type="checkbox"/>	<input type="checkbox"/>		
CTRL HEAT	<input type="checkbox"/>	<input type="checkbox"/>	<input type="checkbox"/>	<input type="checkbox"/>	<input type="checkbox"/>		
HW/STEAM	<input type="checkbox"/>	<input type="checkbox"/>	<input type="checkbox"/>	<input type="checkbox"/>	<input type="checkbox"/>		
ELECTRIC	<input type="checkbox"/>	<input type="checkbox"/>	<input type="checkbox"/>	<input type="checkbox"/>	<input type="checkbox"/>		
HEAT PUMP	<input type="checkbox"/>	<input type="checkbox"/>	<input type="checkbox"/>	<input type="checkbox"/>	<input type="checkbox"/>		
FLR/WALL	<input type="checkbox"/>	<input type="checkbox"/>	<input type="checkbox"/>	<input type="checkbox"/>	<input type="checkbox"/>		
STVE/SPCE	<input type="checkbox"/>	<input type="checkbox"/>	<input type="checkbox"/>	<input type="checkbox"/>	<input type="checkbox"/>		
GEO THERMAL	<input type="checkbox"/>	<input type="checkbox"/>	<input type="checkbox"/>	<input type="checkbox"/>	<input type="checkbox"/>		
OUTSIDE	<input type="checkbox"/>	<input type="checkbox"/>	<input type="checkbox"/>	<input type="checkbox"/>	<input type="checkbox"/>		
CTRL A/C	<input type="checkbox"/>	<input type="checkbox"/>	<input type="checkbox"/>	<input type="checkbox"/>	<input type="checkbox"/>		
PLUMBING		BASE				<input type="checkbox"/>	
X FULL BATH							
X HALF BATH							
X FIXTURES							

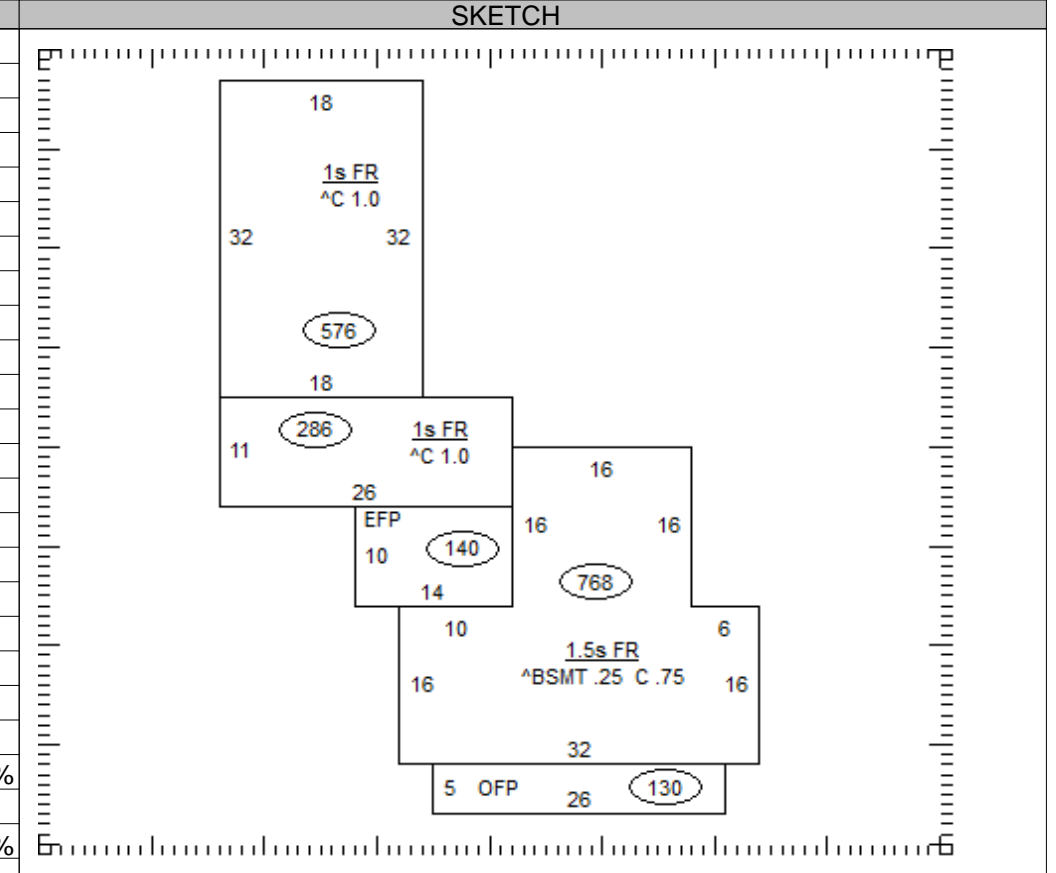

OCCUPANCY	ST.HT	SIZE	AREA	GRADE	PRICE	AGE	REMD	CND	UNADJ VAL	PHYS	PHYS VAL	FUNC	TRUE VAL
DWELLING		SK											
1													
2													
3													
4													
5													
6													
7													
8													
9													
10													
11													

06-020700.0000	TOTAL	0
----------------	-------	---

COMMENTS