

1 OF 3		
PROP. CLASS		
1	1	3
NEIGHBORHOOD		
009061-A100		
M	06	
B		
C	06	

06-016800.0100

MVP DAIRY LLC

MVP DAIRY LLC

PO BOX 968

COLBY, KS 67701

LEGAL INFORMATION

PT W 1/2 NW

RTS: 003-06-09
Acres:77.6370

	OWNERSHIP	ADDRESS	CITY	STATE	ZIP	DATE	AMOUNT	DEED:CONV#	JS	VALID
1	MVP DAIRY LLC	PO BOX 968	COLBY	KS	67701	03/26/2018	1,312,500	2:WDC : 171	<input type="checkbox"/>	<input type="checkbox"/>
2	ELMGLADE HOLDINGS LLC	PO BOX 968	COLBY	KS	67701	03/26/2018	0	2:QCE : X : 0	<input type="checkbox"/>	<input type="checkbox"/>
3	ELMGLADE FARMS LLC	PO BOX 968	COLBY	KS	67701	12/13/2016	1,312,500	2:WDC : 875	<input type="checkbox"/>	<input checked="" type="checkbox"/>

X: TTO LISTER: JK DATE: 03/12/2019 TIME: 12:00:00 AM LETTER LETTER REC'D GIS CODE

STREET/ROAD	TOPOGRAPHY	PU-UTILITIES-PR	NEIGHBORHOOD	INFLUENCE FACTORS	PROPERTY LOCATION
<input type="checkbox"/> PAVED <input type="checkbox"/> GRAVEL <input type="checkbox"/> DIRT <input type="checkbox"/> SIDEWALKS <input type="checkbox"/> CURBS	<input type="checkbox"/> LEVEL <input type="checkbox"/> HIGH <input type="checkbox"/> LOW <input type="checkbox"/> ROLLING <input type="checkbox"/> STANDARD	<input type="checkbox"/> WATER <input type="checkbox"/> SEWER <input type="checkbox"/> GAS <input type="checkbox"/> ELECTRIC <input checked="" type="checkbox"/> STANDARD	<input type="checkbox"/> IMPROVING <input type="checkbox"/> STATIC <input type="checkbox"/> DECLINING <input type="checkbox"/> OLD <input type="checkbox"/> STANDARD	<input type="checkbox"/> A. NO ROAD <input type="checkbox"/> B. TOPGRHY <input type="checkbox"/> C. Ex Front <input type="checkbox"/> D. QUANTITY <input type="checkbox"/> E. SZ/SHAPE	<input type="checkbox"/> F. RESTRICT <input type="checkbox"/> G. WOOD LT <input type="checkbox"/> H. VACANCY <input type="checkbox"/> I. WATER FRONT <input type="checkbox"/> J. OTHER/CDU

7124 US RT 33 , CELINA
COMMENT
Tax Incentive Exempt Parcel: (1) 06-016800.010K (TY2019 L=0; B=5,044,900; T=5,044,900) TY2018:Net Gen=\$4,056.88, Other Assessment=\$3,027.08 DE19 ADD BLDG VALUE; 75% TIF DE18 LARGE DAIRY //CREATE TIF DISTRICT//started after 1/1/2017 2017 DUPL BLDG VALUE: \$0 2018 DUPL BLDG VALUE: \$6,897,100 NC28 TIF EXPIRES TAX INCENTIVE: TIF512 TIF EXPIRES 2028TY/2019CY

LAND COMPUTATIONS								
LAND TYPE	SIZE	M	RATE	C	INF	M	VALUE	C
BL:Barn Lot:0690	A 25.0000	5,000	5,000			125,000	125,000	
CR:Crop Land TOTAL	A 50.5970	8,907	2,475			462,400	140,260	
0069	A 5.6000	8,790	2,280			49,220	12,770	
0070	A 13.0000	8,450	1,955			109,850	25,420	
0087	A 31.9970	9,480	3,190			303,330	102,070	
RD:Road:0900	A 1.5400	0	0			0	0	
WS:Waste:0990	A .5000	100	50			50	30	
Total Acres: 77.6370						TOTAL	587,450	265,290

VALUATION SUMMARY								
VALUE YEAR	2019	2019	2018	2018	2017	2017	2014	2014
REASON FOR CHANGE	CAUV	NC	CAUV	MISC	CAUV	RAPP	CAUV	RAPP
APPRAISED	265,290	587,450	265,290	587,450	220,040	699,450	281,490	645,640
VALUE	LAND	IMPR	TOTAL	LAND	IMPR	TOTAL	LAND	IMPR
	1,852,200	1,852,200	0	0	0	0	0	0
	2,117,490	2,439,650	265,290	587,450	220,040	699,450	281,490	645,640
ASSESSED	92,850	205,610	92,850	205,610	77,010	244,810	98,520	225,970
VALUE	LAND	IMPR	TOTAL	LAND	IMPR	TOTAL	LAND	IMPR
	648,270	648,270	0	0	0	0	0	0
	741,120	853,880	92,850	205,610	77,010	244,810	98,520	225,970
CAUV TAX SAVINGS	2018=4926.82, 2017=7332.90, 2016=5445.96: Total=17705.68							

OCCUPANCY		EXTERIOR		FLOOR	AREA	CONST	VALUE
<input type="checkbox"/> SNGL FMLY	<input type="checkbox"/> WOOD						
<input type="checkbox"/> DUPLEX	<input type="checkbox"/> STUCCO						
<input type="checkbox"/> TRIPLEX	<input type="checkbox"/> ALM/VYNL						
<input type="checkbox"/> CONVR	<input type="checkbox"/> CONC BLK						
<input type="checkbox"/> MOBILE HM	<input type="checkbox"/> METAL						
<input type="checkbox"/> BI/L TRI/L	<input type="checkbox"/> BRICK						
<input type="checkbox"/> MOD/MAN	<input type="checkbox"/> STONE						
ROOFING		ROOF TYPE					
<input type="checkbox"/> METAL	<input type="checkbox"/> GABLE						
<input type="checkbox"/> SLT/TLE	<input type="checkbox"/> HIP						
<input type="checkbox"/> SHINGLES	<input type="checkbox"/> GAMBREL						
<input type="checkbox"/> SHAKES	<input type="checkbox"/> MANSARD						
<input type="checkbox"/> COMPOSITE	<input type="checkbox"/> FLAT						
SUBTOTAL							0
FLOORS		B	1	2	3	U	
CONCRETE	<input type="checkbox"/>	<input type="checkbox"/>	<input type="checkbox"/>	<input type="checkbox"/>	<input type="checkbox"/>	<input type="checkbox"/>	MULTI-FAMILY # 0
WOOD	<input type="checkbox"/>	<input type="checkbox"/>	<input type="checkbox"/>	<input type="checkbox"/>	<input type="checkbox"/>	<input type="checkbox"/>	BSMT FINISH 0 S.F.
TILE/COMPO	<input type="checkbox"/>	<input type="checkbox"/>	<input type="checkbox"/>	<input type="checkbox"/>	<input type="checkbox"/>	<input type="checkbox"/>	FIREPLACE # 0
CARPET	<input type="checkbox"/>	<input type="checkbox"/>	<input type="checkbox"/>	<input type="checkbox"/>	<input type="checkbox"/>	<input type="checkbox"/>	HEATING 0 S.F.
							AIR COND 0 S.F.
INT. FINISH		B	1	2	3	U	
PLASTER/DW	<input type="checkbox"/>	<input type="checkbox"/>	<input type="checkbox"/>	<input type="checkbox"/>	<input type="checkbox"/>	<input type="checkbox"/>	PLUMBING # 0
PANELING	<input type="checkbox"/>	<input type="checkbox"/>	<input type="checkbox"/>	<input type="checkbox"/>	<input type="checkbox"/>	<input type="checkbox"/>	GARAGES & CARPORTS 0
UNFINISHED	<input type="checkbox"/>	<input type="checkbox"/>	<input type="checkbox"/>	<input type="checkbox"/>	<input type="checkbox"/>	<input type="checkbox"/>	EXTRA FEATURES 0
ACCOMMODATIONS							0
# OF ROOMS							GRADE FACTOR %
BEDROOMS							UNADJUSTED VALUE 0
FIREPLACES							FACTOR %
HEAT & AC		B	1	2	3	U	
NO HEAT	<input type="checkbox"/>	<input type="checkbox"/>	<input type="checkbox"/>	<input type="checkbox"/>	<input type="checkbox"/>	<input type="checkbox"/>	
CTRL HEAT	<input type="checkbox"/>	<input type="checkbox"/>	<input type="checkbox"/>	<input type="checkbox"/>	<input type="checkbox"/>	<input type="checkbox"/>	
HW/STEAM	<input type="checkbox"/>	<input type="checkbox"/>	<input type="checkbox"/>	<input type="checkbox"/>	<input type="checkbox"/>	<input type="checkbox"/>	
ELECTRIC	<input type="checkbox"/>	<input type="checkbox"/>	<input type="checkbox"/>	<input type="checkbox"/>	<input type="checkbox"/>	<input type="checkbox"/>	
HEAT PUMP	<input type="checkbox"/>	<input type="checkbox"/>	<input type="checkbox"/>	<input type="checkbox"/>	<input type="checkbox"/>	<input type="checkbox"/>	
FLR/WALL	<input type="checkbox"/>	<input type="checkbox"/>	<input type="checkbox"/>	<input type="checkbox"/>	<input type="checkbox"/>	<input type="checkbox"/>	
STVE/SPCE	<input type="checkbox"/>	<input type="checkbox"/>	<input type="checkbox"/>	<input type="checkbox"/>	<input type="checkbox"/>	<input type="checkbox"/>	
GEOHERMAL	<input type="checkbox"/>	<input type="checkbox"/>	<input type="checkbox"/>	<input type="checkbox"/>	<input type="checkbox"/>	<input type="checkbox"/>	
OUTSIDE	<input type="checkbox"/>	<input type="checkbox"/>	<input type="checkbox"/>	<input type="checkbox"/>	<input type="checkbox"/>	<input type="checkbox"/>	
CTRL A/C	<input type="checkbox"/>	<input type="checkbox"/>	<input type="checkbox"/>	<input type="checkbox"/>	<input type="checkbox"/>	<input type="checkbox"/>	
PLUMBING							
X FULL BATH							
X HALF BATH							
X FIXTURES							

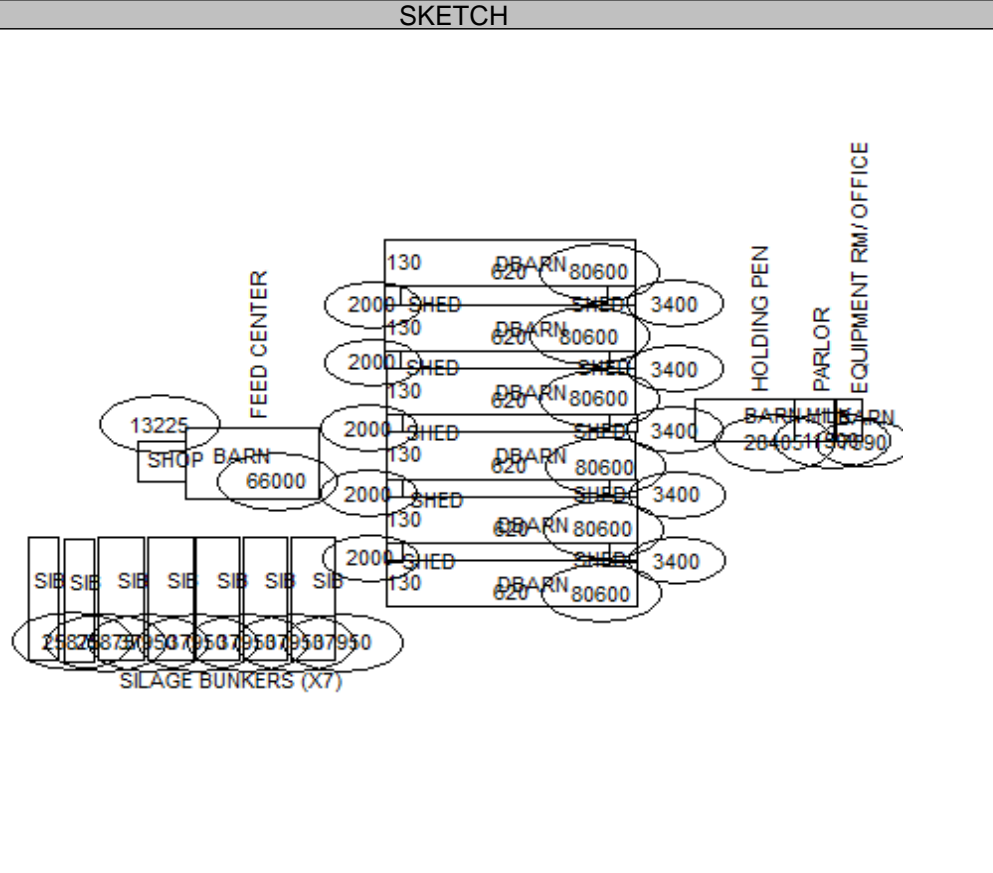

OCCUPANCY	ST.HT	SIZE	AREA	GRADE	PRICE	AGE	REMD	CND	UNADJ VAL	PHYS	PHYS VAL	FUNC	TRUE VAL
DWELLING		SK											
1 Barn-Dairy		130x620	80,600	C	13.00	2018		A	1,047,800	2	1,026,840	TIF75	256,700
2 Barn-Dairy		130x620	80,600	C	13.00	2018		A	1,047,800	2	1,026,840	TIF75	256,700
3 Barn-Dairy		130x620	80,600	C	13.00	2018		A	1,047,800	2	1,026,840	TIF75	256,700
4 Barn-Dairy		130x620	80,600	C	13.00	2018		A	1,047,800	2	1,026,840	TIF75	256,700
5 Barn-Dairy		130x620	80,600	C	13.00	2018		A	1,047,800	2	1,026,840	TIF75	256,700
6 Barn-Dairy		130x620	80,600	C	13.00	2018		A	1,047,800	2	1,026,840	TIF75	256,700
7 Barn		115x247	28,405	C	8.00	2018		A	227,240	2	222,700	TIF75	55,700
8 Milk House / Par		115x100	11,500	C	12.00	2018		A	138,000	2	135,240	TIF75	33,800
9 Barn		115x66	7,590	C	8.00	2018		A	60,720	2	59,510	TIF75	14,900
10 Barn		200x330	66,000	C	8.00	2018		A	528,000	2	517,440	TIF75	129,400
11 Shop - Stud		115x115	13,225	C	12.50	2018		A	165,310	2	162,000	TIF75	40,500

06-016800.0100

TOTAL 1,814,500

COMMENTS

2 OF 3		
PROP. CLASS		
1	1	3
NEIGHBORHOOD		
009061-A100		
M	06	
B		
C	06	

06-016800.0100

MVP DAIRY LLC
MVP DAIRY LLC
PO BOX 968
COLBY, KS 67701

LEGAL INFORMATION
PT W 1/2 NW

RTS: 003-06-09
Acres:77.6370

	OWNERSHIP	ADDRESS	CITY	STATE	ZIP	DATE	AMOUNT	DEED:CONV#	JS	VALID
1	HOUTS MARK ELDON &	3056 FRAHM PIKE	CELINA	OH	45822	05/20/1991	54,200	: F-M : 0	<input type="checkbox"/>	<input type="checkbox"/>
2							0	0	<input type="checkbox"/>	<input type="checkbox"/>
3							0	0	<input type="checkbox"/>	<input type="checkbox"/>

X: TTO LISTER: JK DATE: 03/12/2019 TIME: 12:00:00 AM LETTER LETTER REC'D GIS CODE

STREET/ROAD	TOPOGRAPHY	PU-UTILITIES-PR	NEIGHBORHOOD	INFLUENCE FACTORS	PROPERTY LOCATION
<input type="checkbox"/> PAVED <input type="checkbox"/> GRAVEL <input type="checkbox"/> DIRT <input type="checkbox"/> SIDEWALKS <input type="checkbox"/> CURBS	<input type="checkbox"/> LEVEL <input type="checkbox"/> HIGH <input type="checkbox"/> LOW <input type="checkbox"/> ROLLING <input type="checkbox"/> STANDARD	<input type="checkbox"/> WATER <input type="checkbox"/> SEWER <input type="checkbox"/> GAS <input type="checkbox"/> ELECTRIC <input checked="" type="checkbox"/> STANDARD	<input type="checkbox"/> IMPROVING <input type="checkbox"/> STATIC <input type="checkbox"/> DECLINING <input type="checkbox"/> OLD <input type="checkbox"/> STANDARD	<input type="checkbox"/> A. NO ROAD <input type="checkbox"/> B. TOPGRHY <input type="checkbox"/> C. Ex Front <input type="checkbox"/> D. QUANTITY <input type="checkbox"/> E. SZ/SHAPE	<input type="checkbox"/> F. RESTRICT <input type="checkbox"/> G. WOOD LT <input type="checkbox"/> H. VACANCY <input type="checkbox"/> I. WATER FRONT <input type="checkbox"/> J. OTHER/CDU
					7124 US RT 33 , CELINA
COMMENT					

LAND COMPUTATIONS							
LAND TYPE	SIZE	M	RATE	C	INF	M	VALUE C
Total Acres: 77.6370					TOTAL	587,450	265,290

VALUATION SUMMARY							
VALUE YEAR	2011	2011					
REASON FOR CHANGE	CAUV	RAPP					
APPRaised	LAND	124,960	445,800				
VALUE	IMPR	0	0				
	TOTAL	124,960	445,800				
ASSESSED	LAND	43,740	156,030				
VALUE	IMPR	0	0				
	TOTAL	43,740	156,030				
CAUV TAX SAVINGS	2018=4926.82, 2017=7332.90, 2016=5445.96: Total=17705.68						

3 OF 3		
PROP. CLASS		
1	1	3
NEIGHBORHOOD		
009061-A100		
M	06	
B		
C	06	

06-016800.0100

MVP DAIRY LLC

MVP DAIRY LLC
PO BOX 968
COLBY, KS 67701

LEGAL INFORMATION

PT W 1/2 NW

RTS: 003-06-09
Acres:77.6370

	OWNERSHIP	ADDRESS	CITY	STATE	ZIP	DATE	AMOUNT	DEED:CONV#	JS	VALID
1	MVP DAIRY LLC	PO BOX 968	COLBY	KS	67701	03/26/2018	1,312,500	2:WDC : 171	<input type="checkbox"/>	<input type="checkbox"/>
2	ELMGLADE HOLDINGS LLC	PO BOX 968	COLBY	KS	67701	03/26/2018	0	2:QCE : X : 0	<input type="checkbox"/>	<input type="checkbox"/>
3	ELMGLADE FARMS LLC	PO BOX 968	COLBY	KS	67701	12/13/2016	1,312,500	2:WDC : 875	<input type="checkbox"/>	<input checked="" type="checkbox"/>

X: TTO LISTER: JK DATE: 03/12/2019 TIME: 12:00:00 AM LETTER LETTER REC'D GIS CODE

STREET/ROAD	TOPOGRAPHY	PU-UTILITIES-PR	NEIGHBORHOOD	INFLUENCE FACTORS	PROPERTY LOCATION
<input type="checkbox"/> PAVED <input type="checkbox"/> GRAVEL <input type="checkbox"/> DIRT <input type="checkbox"/> SIDEWALKS <input type="checkbox"/> CURBS	<input type="checkbox"/> LEVEL <input type="checkbox"/> HIGH <input type="checkbox"/> LOW <input type="checkbox"/> ROLLING <input type="checkbox"/> STANDARD	<input type="checkbox"/> WATER <input type="checkbox"/> SEWER <input type="checkbox"/> GAS <input type="checkbox"/> ELECTRIC <input checked="" type="checkbox"/> STANDARD	<input type="checkbox"/> IMPROVING <input type="checkbox"/> STATIC <input type="checkbox"/> DECLINING <input type="checkbox"/> OLD <input type="checkbox"/> STANDARD	<input type="checkbox"/> A. NO ROAD <input type="checkbox"/> B. TOPGRHY <input type="checkbox"/> C. Ex Front <input type="checkbox"/> D. QUANTITY <input type="checkbox"/> E. SZ/SHAPE	<input type="checkbox"/> F. RESTRICT <input type="checkbox"/> G. WOOD LT <input type="checkbox"/> H. VACANCY <input type="checkbox"/> I. WATER FRONT <input type="checkbox"/> J. OTHER/CDU
					7124 US RT 33 , CELINA
COMMENT					

LAND COMPUTATIONS							
LAND TYPE	SIZE	M	RATE	C	INF	M	VALUE C
Total Acres: 77.6370					TOTAL	587,450	265,290

VALUATION SUMMARY

VALUE YEAR	REASON FOR CHANGE	APPRaised	IMPR	TOTAL	ASSESSED	IMPR	TOTAL	CAUV TAX SAVINGS
2018=4926.82, 2017=7332.90, 2016=5445.96: Total=17705.68								

OCCUPANCY		EXTERIOR		FLOOR	AREA	CONST	VALUE
<input type="checkbox"/> SNGL FMLY	<input type="checkbox"/> WOOD						
<input type="checkbox"/> DUPLEX	<input type="checkbox"/> STUCCO						
<input type="checkbox"/> TRIPLEX	<input type="checkbox"/> ALM/VYNL						
<input type="checkbox"/> CONVR	<input type="checkbox"/> CONC BLK						
<input type="checkbox"/> MOBILE HM	<input type="checkbox"/> METAL						
<input type="checkbox"/> BI/L TRI/L	<input type="checkbox"/> BRICK						
<input type="checkbox"/> MOD/MAN	<input type="checkbox"/> STONE						
ROOFING		ROOF TYPE					
<input type="checkbox"/> METAL	<input type="checkbox"/> GABLE						
<input type="checkbox"/> SLT/TLE	<input type="checkbox"/> HIP						
<input type="checkbox"/> SHINGLES	<input type="checkbox"/> GAMBREL						
<input type="checkbox"/> SHAKES	<input type="checkbox"/> MANSARD						
<input type="checkbox"/> COMPOSITE	<input type="checkbox"/> FLAT						
SUBTOTAL							0
FLOORS		B	1	2	3	U	
CONCRETE	<input type="checkbox"/>	<input type="checkbox"/>	<input type="checkbox"/>	<input type="checkbox"/>	<input type="checkbox"/>	<input type="checkbox"/>	
WOOD	<input type="checkbox"/>	<input type="checkbox"/>	<input type="checkbox"/>	<input type="checkbox"/>	<input type="checkbox"/>	<input type="checkbox"/>	
TILE/COMPO	<input type="checkbox"/>	<input type="checkbox"/>	<input type="checkbox"/>	<input type="checkbox"/>	<input type="checkbox"/>	<input type="checkbox"/>	
CARPET	<input type="checkbox"/>	<input type="checkbox"/>	<input type="checkbox"/>	<input type="checkbox"/>	<input type="checkbox"/>	<input type="checkbox"/>	
INT. FINISH		B	1	2	3	U	
PLASTER/DW	<input type="checkbox"/>	<input type="checkbox"/>	<input type="checkbox"/>	<input type="checkbox"/>	<input type="checkbox"/>	<input type="checkbox"/>	
PANELING	<input type="checkbox"/>	<input type="checkbox"/>	<input type="checkbox"/>	<input type="checkbox"/>	<input type="checkbox"/>	<input type="checkbox"/>	
UNFINISHED	<input type="checkbox"/>	<input type="checkbox"/>	<input type="checkbox"/>	<input type="checkbox"/>	<input type="checkbox"/>	<input type="checkbox"/>	
ACCOMMODATIONS							
# OF ROOMS							
BEDROOMS							
FIREPLACES							
HEAT & AC	B	1	2	3	U		
NO HEAT	<input type="checkbox"/>	<input type="checkbox"/>	<input type="checkbox"/>	<input type="checkbox"/>	<input type="checkbox"/>	<input type="checkbox"/>	
CTRL HEAT	<input type="checkbox"/>	<input type="checkbox"/>	<input type="checkbox"/>	<input type="checkbox"/>	<input type="checkbox"/>	<input type="checkbox"/>	
HW/STEAM	<input type="checkbox"/>	<input type="checkbox"/>	<input type="checkbox"/>	<input type="checkbox"/>	<input type="checkbox"/>	<input type="checkbox"/>	
ELECTRIC	<input type="checkbox"/>	<input type="checkbox"/>	<input type="checkbox"/>	<input type="checkbox"/>	<input type="checkbox"/>	<input type="checkbox"/>	
HEAT PUMP	<input type="checkbox"/>	<input type="checkbox"/>	<input type="checkbox"/>	<input type="checkbox"/>	<input type="checkbox"/>	<input type="checkbox"/>	
FLR/WALL	<input type="checkbox"/>	<input type="checkbox"/>	<input type="checkbox"/>	<input type="checkbox"/>	<input type="checkbox"/>	<input type="checkbox"/>	
STVE/SPCE	<input type="checkbox"/>	<input type="checkbox"/>	<input type="checkbox"/>	<input type="checkbox"/>	<input type="checkbox"/>	<input type="checkbox"/>	
GEOHERMAL	<input type="checkbox"/>	<input type="checkbox"/>	<input type="checkbox"/>	<input type="checkbox"/>	<input type="checkbox"/>	<input type="checkbox"/>	
OUTSIDE	<input type="checkbox"/>	<input type="checkbox"/>	<input type="checkbox"/>	<input type="checkbox"/>	<input type="checkbox"/>	<input type="checkbox"/>	
CTRL A/C	<input type="checkbox"/>	<input type="checkbox"/>	<input type="checkbox"/>	<input type="checkbox"/>	<input type="checkbox"/>	<input type="checkbox"/>	
PLUMBING							
X FULL BATH							
X HALF BATH							
X FIXTURES							
SUBTOTAL							0
GRADE FACTOR							%
UNADJUSTED VALUE							0
FACTOR							%

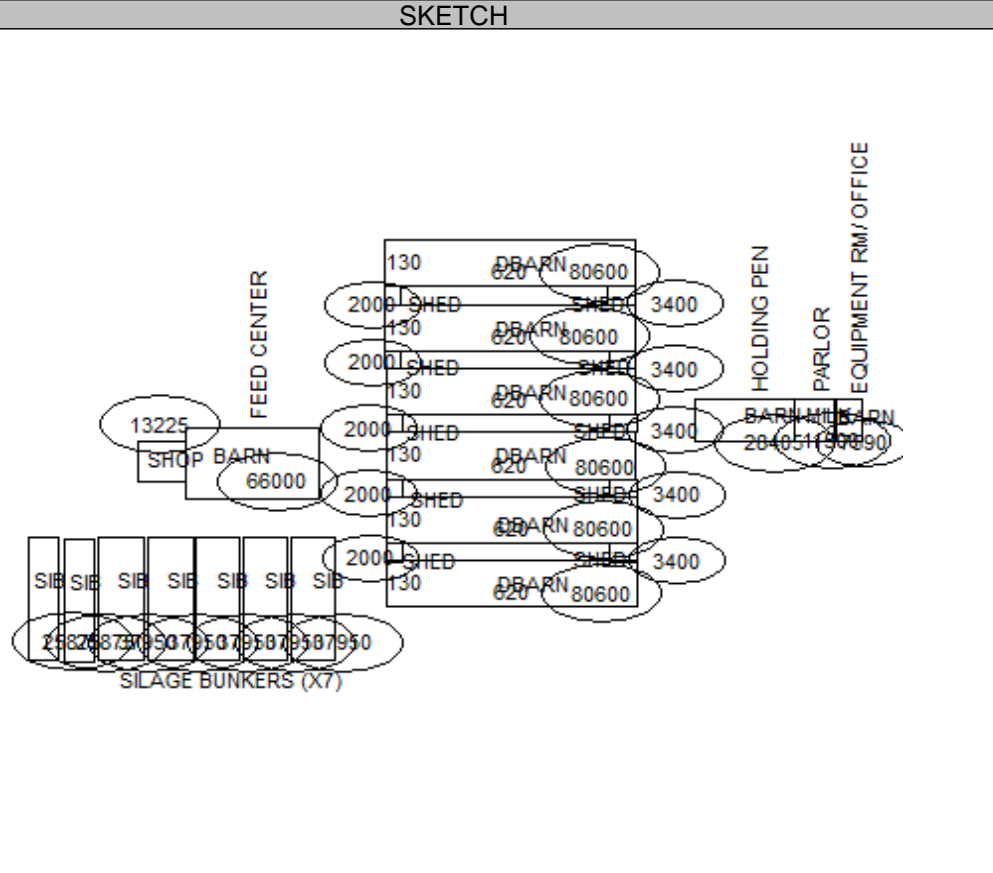

OCCUPANCY	ST.HT	SIZE	AREA	GRADE	PRICE	AGE	REMD	CND	UNADJ VAL	PHYS	PHYS VAL	FUNC	TRUE VAL
DWELLING		SK											
1 Shed		50x40	2,000	C	4.00	2018		A	8,000	2	7,840	TIF75	2,000
2 Shed		50x40	2,000	C	4.00	2018		A	8,000	2	7,840	TIF75	2,000
3 Shed		50x40	2,000	C	4.00	2018		A	8,000	2	7,840	TIF75	2,000
4 Shed		50x68	3,400	C	6.45	2018		A	21,930	2	21,490	TIF75	5,400
5 Shed		50x40	2,000	C	4.00	2018		A	8,000	2	7,840	TIF75	2,000
6 Shed		50x68	3,400	C	6.45	2018		A	21,930	2	21,490	TIF75	5,400
7													
8													
9													
10													
11													

06-016800.0100

TOTAL 18,800

COMMENTS