

BUTLER TWP-COLDWATER CORP / COLDWATER SD
08-28-451-017

05-111400.0000
OSBORNE ARON & KRISTEN
OSBORNE ARON & KRISTEN
624 PLUM DR
COLDWATER, OH 45828

LEGAL INFORMATION
SELHORST FOURTH ADDITION

LOT#: 726

	OWNERSHIP	ADDRESS	CITY	STATE	ZIP	DATE	AMOUNT	DEED:CONV#	JS	VALID
1	OSBORNE ARON & KRISTEN	624 PLUM DR	COLDWATER	OH	45828	11/20/2017	161,000	WDC : 798	<input type="checkbox"/>	<input checked="" type="checkbox"/>
2	GRIESHOP KURT R & WENDY	624 PLUM DR	COLDWATER	OH	45828	07/10/1992	89,000	: A : 0	<input type="checkbox"/>	<input checked="" type="checkbox"/>
3							0	0	<input type="checkbox"/>	<input type="checkbox"/>

X: TTO LISTER: NS DATE: 01/21/2005 TIME: 12:00:00 AM LETTER LETTER REC'D GIS CODE

STREET/ROAD	TOPOGRAPHY	PU-UTILITIES-PR	NEIGHBORHOOD	INFLUENCE FACTORS	PROPERTY LOCATION
<input checked="" type="checkbox"/> PAVED	<input checked="" type="checkbox"/> LEVEL	<input type="checkbox"/> WATER	<input type="checkbox"/> IMPROVING	<input type="checkbox"/> A. NO ROAD	624 PLUM DR, COLDWATER COMMENT TY2018:Net Gen=\$1,789.04, Other Assessment=\$0.00 DE15 PER DATA MAILER CORR PLMB DE18 REMOVE OWN OCC didn't return app
<input type="checkbox"/> GRAVEL	<input type="checkbox"/> HIGH	<input type="checkbox"/> SEWER	<input checked="" type="checkbox"/> STATIC	<input type="checkbox"/> B. TOPGRHY	
<input type="checkbox"/> DIRT	<input type="checkbox"/> LOW	<input type="checkbox"/> GAS	<input type="checkbox"/> DECLINING	<input type="checkbox"/> C. Ex Front	
<input checked="" type="checkbox"/> SIDEWALKS	<input type="checkbox"/> ROLLING	<input type="checkbox"/> ELECTRIC	<input type="checkbox"/> OLD	<input type="checkbox"/> D. QUANTITY	
<input type="checkbox"/> CURBS	<input type="checkbox"/> STANDARD	<input checked="" type="checkbox"/> STANDARD	<input type="checkbox"/> STANDARD	<input type="checkbox"/> E. SZ/SHAPE	
				<input type="checkbox"/> F. RESTRICT	
				<input type="checkbox"/> G. WOOD LT	
				<input type="checkbox"/> H. VACANCY	
				<input type="checkbox"/> I. WATER FRONT	
				<input type="checkbox"/> J. OTHER/CDU	

LAND COMPUTATIONS						
LAND TYPE	SIZE	M	RATE	C	INF	M VALUE
F:Front	F70 D130					16,900
						0
TOTAL						16,900

VALUATION SUMMARY					
VALUE YEAR	2017	2015	2014	2011	
REASON FOR CHANGE	RAPP	NC	RAPP	RAPP	
APPRaised	16,900	18,100	18,100	16,900	
VALUE	IMPR	121,400	94,600	91,600	85,600
	TOTAL	138,300	112,700	109,700	102,500
ASSESSED	LAND	5,920	6,340	6,340	5,920
VALUE	IMPR	42,490	33,110	32,060	29,960
	TOTAL	48,410	39,450	38,400	35,880

OCCUPANCY	EXTERIOR	FLOOR	AREA	CONST	VALUE	
<input checked="" type="checkbox"/> SNGL FMLY	<input checked="" type="checkbox"/> WOOD	1	1404	FR	110,440	
<input type="checkbox"/> DUPLEX	<input type="checkbox"/> STUCCO	.25	295	FR	17,640	
<input type="checkbox"/> TRIPLEX	<input checked="" type="checkbox"/> ALM/VYNL					
<input type="checkbox"/> CONVR	<input type="checkbox"/> CONC BLK					
<input type="checkbox"/> MOBILE HM	<input type="checkbox"/> METAL					
<input type="checkbox"/> BI/L TRI/L	<input type="checkbox"/> BRICK					
<input type="checkbox"/> MOD/MAN	<input type="checkbox"/> STONE					
ROOFING	ROOF TYPE					
<input type="checkbox"/> METAL	<input checked="" type="checkbox"/> GABLE					
<input type="checkbox"/> SLT/TLE	<input type="checkbox"/> HIP					
<input checked="" type="checkbox"/> SHINGLES	<input type="checkbox"/> GAMBREL					
<input type="checkbox"/> SHAKES	<input type="checkbox"/> MANSARD					
<input type="checkbox"/> COMPOSITE	<input type="checkbox"/> FLAT					
		BSMT	1180		15,340	
SUBTOTAL					143,420	
FLOORS	B 1 2 3 U	MULTI-FAMILY # 0			0	
CONCRETE	<input checked="" type="checkbox"/> <input type="checkbox"/> <input type="checkbox"/> <input type="checkbox"/> <input type="checkbox"/>	BSMT FINISH 295 S.F.			3,840	
WOOD	<input type="checkbox"/> <input checked="" type="checkbox"/> <input checked="" type="checkbox"/> <input type="checkbox"/> <input type="checkbox"/>	FIREPLACE # 0			0	
TILE/COMPO	<input type="checkbox"/> <input type="checkbox"/> <input type="checkbox"/> <input type="checkbox"/> <input type="checkbox"/>	HEATING 0 S.F.			0	
CARPET	<input checked="" type="checkbox"/> <input type="checkbox"/> <input type="checkbox"/> <input type="checkbox"/> <input type="checkbox"/>	AIR COND 1,404 S.F.			2,110	
INT. FINISH	B 1 2 3 U	PLUMBING # 8			8,800	
PLASTER/DW	<input type="checkbox"/> <input checked="" type="checkbox"/> <input checked="" type="checkbox"/> <input type="checkbox"/> <input type="checkbox"/>	GARAGES & CARPORTS			5,800	
PANELING	<input checked="" type="checkbox"/> <input type="checkbox"/> <input type="checkbox"/> <input type="checkbox"/> <input type="checkbox"/>	EXTRA FEATURES			8,900	
UNFINISHED	<input type="checkbox"/> <input type="checkbox"/> <input type="checkbox"/> <input type="checkbox"/> <input type="checkbox"/>	SUBTOTAL 172,870				
ACCOMMODATIONS		GRADE FACTOR			100 %	
# OF ROOMS	3 4 2	UNADJUSTED VALUE			172,870	
BEDROOMS	2 2	FACTOR 100 %				
FIREPLACES						
HEAT & AC	B 1 2 3 U					
NO HEAT	<input type="checkbox"/> <input type="checkbox"/> <input type="checkbox"/> <input type="checkbox"/> <input type="checkbox"/>					
CTRL HEAT	<input checked="" type="checkbox"/> <input checked="" type="checkbox"/> <input checked="" type="checkbox"/> <input type="checkbox"/> <input type="checkbox"/>					
HW/STEAM	<input type="checkbox"/> <input type="checkbox"/> <input type="checkbox"/> <input type="checkbox"/> <input type="checkbox"/>					
ELECTRIC	<input type="checkbox"/> <input type="checkbox"/> <input type="checkbox"/> <input type="checkbox"/> <input type="checkbox"/>					
HEAT PUMP	<input type="checkbox"/> <input type="checkbox"/> <input type="checkbox"/> <input type="checkbox"/> <input type="checkbox"/>					
FLR/WALL	<input type="checkbox"/> <input type="checkbox"/> <input type="checkbox"/> <input type="checkbox"/> <input type="checkbox"/>					
STVE/SPCE	<input type="checkbox"/> <input type="checkbox"/> <input type="checkbox"/> <input type="checkbox"/> <input type="checkbox"/>					
GEOHERMAL	<input type="checkbox"/> <input type="checkbox"/> <input type="checkbox"/> <input type="checkbox"/> <input type="checkbox"/>					
OUTSIDE	<input type="checkbox"/> <input type="checkbox"/> <input type="checkbox"/> <input type="checkbox"/> <input type="checkbox"/>					
CTRL A/C	<input type="checkbox"/> <input checked="" type="checkbox"/> <input type="checkbox"/> <input type="checkbox"/> <input type="checkbox"/>					
PLUMBING	BASE <input checked="" type="checkbox"/>					
X FULL BATH	1					
X HALF BATH	2					
X FIXTURES	1					

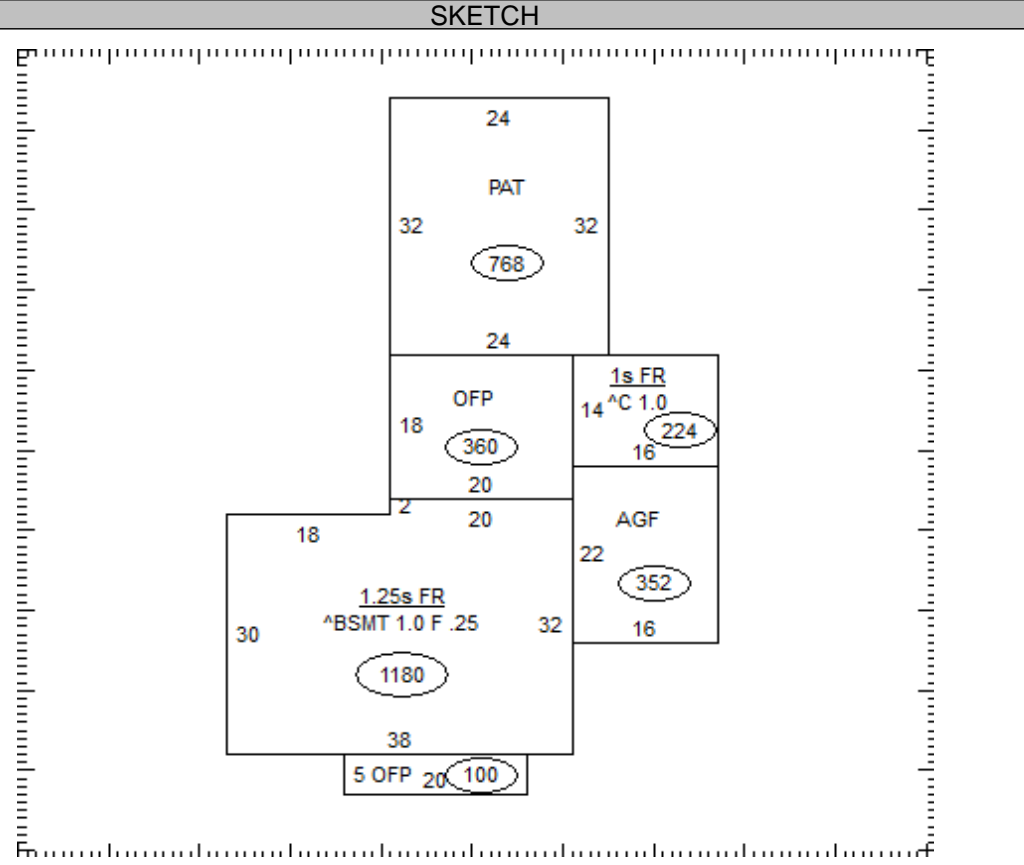

OCCUPANCY	ST.HT	SIZE	AREA	GRADE	PRICE	AGE	REMD	CND	UNADJ VAL	PHYS	PHYS VAL	FUNC	TRUE VAL
DWELLING	1.25	SK	1,699	C		1957		A	172,870	40	103,720		121,400
1													
2													
3													
4													
5													
6													
7													
8													
9													
10													
11													

05-111400.0000

TOTAL 121,400

COMMENTS
 Dwelling has an Economic Factor of 117%