



\*05-178800.0000\*

BUTLER TOWNSHIP / COLDWATER CORPORATION  
08-28-152-005

1 OF 1		
PROP. CLASS		
5	1	0
NEIGHBORHOOD		
000510-TS60		
M	01	
B	01	
C	22	

**THOMPSON ROBERT D & LOUANNA S**  
THOMPSON ROBERT D & LOUANNA S  
1000 GARNET CT  
COLDWATER, OH 45828

**LEGAL INFORMATION**  
WESTVIEW THIRD ADD

LOT#: 1380

	OWNERSHIP	MAILING ADDRESS	CITY	STATE	ZIP	DATE	AMOUNT	CONV #	JS	VALID
1	THOMPSON ROBERT D & ...	1000 GARNET CT	COLDWATER	OH	45828	07/02/2010	201000	WDC : A : 398	<input type="checkbox"/>	<input checked="" type="checkbox"/>
2	MEIHAUS STANLEY A JR & ...	1000 GARNET CT	COLDWATER	OH	45828-1088...	06/05/1995	17500	: A : 0	<input type="checkbox"/>	<input checked="" type="checkbox"/>
3							0		<input type="checkbox"/>	<input type="checkbox"/>

X: LISTER: btc DATE: 05/03/2010 TIME: 12:00:00 AM  LETTER  LETTER REC'D GIS CODE

STREET/ROAD	TOPOGRAPHY	PU-UTILITIES-PR	NEIGHBORHOOD	INFLUENCE FACTORS	PROPERTY LOCATION
<input checked="" type="checkbox"/> PAVED <input type="checkbox"/> GRAVEL <input type="checkbox"/> DIRT <input checked="" type="checkbox"/> SIDEWALKS <input type="checkbox"/> CURBS	<input type="checkbox"/> LEVEL <input type="checkbox"/> HIGH <input type="checkbox"/> LOW <input type="checkbox"/> ROLLING <input type="checkbox"/> STANDARD	<input type="checkbox"/> WATER <input type="checkbox"/> SEWER <input type="checkbox"/> GAS <input type="checkbox"/> ELECTRIC <input checked="" type="checkbox"/> STANDARD	<input type="checkbox"/> IMPROVING <input type="checkbox"/> STATIC <input type="checkbox"/> DECLINING <input type="checkbox"/> OLD <input checked="" type="checkbox"/> STANDARD	<input type="checkbox"/> A. NO ROAD <input type="checkbox"/> B. TOPGRHY <input type="checkbox"/> C. EX FRONT <input type="checkbox"/> D. QUANTITY <input type="checkbox"/> E. SZ/SHAPE	<input type="checkbox"/> F. RESTRICT <input type="checkbox"/> G. WOOD LT <input type="checkbox"/> H. VACANCY <input type="checkbox"/> I. WATER FRONT <input type="checkbox"/> J. OTHER/CDU
					1000 GARNET CT, COLDWATER
					COMMENT DE11 REMOVED BOR FNC TY2011:Net Gen=\$3,246.74, Net Spec=\$0.00

LAND COMPUTATIONS							
CODES:	LAND TYPE	SIZE	M	RATE	C	INF	M VALUE C
F: FRONT R: REAR	FR:F	F95 D155	ST280	DP102	ADJ286		27200 0
HS: HOME SITE							
SM: SMALL ACRE							
WA: WASTE							
RD: ROAD							
EA: EASEMENT							
TOTAL							27200 0

VALUATION SUMMARY							
ASSESSMENT YEAR	2011	2011	2010	2008			
REASON FOR CHANGE	RAPP	MISC	BOR	RAPP			
APPRAISED	LAND	27200	27200	24200	24200		
VALUE	IMPR	203300	203400	176400	220200		
	TOTAL	230500	230600	200600	244400		
ASSESSED	LAND	9520	9520	8470	8470		
VALUE	IMPR	71160	71190	61740	77070		
	TOTAL	80680	80710	70210	85540		

OCCUPANCY	EXTERIOR
<input checked="" type="checkbox"/> SINGL FMLY	<input type="checkbox"/> WOOD
<input type="checkbox"/> DUPLEX	<input type="checkbox"/> STUCCO
<input type="checkbox"/> TRIPLEX	<input type="checkbox"/> ALM/VYNL
<input type="checkbox"/> CONVR	<input type="checkbox"/> CONC BLK
<input type="checkbox"/> MOBILE HM	<input type="checkbox"/> METAL
<input type="checkbox"/> BI/L TRI/L	<input checked="" type="checkbox"/> BRICK
<input type="checkbox"/> MOD/MAN	<input type="checkbox"/> STONE

ROOFING	ROOF TYPE
<input type="checkbox"/> METAL	<input checked="" type="checkbox"/> GABLE
<input type="checkbox"/> SLT/TLE	<input type="checkbox"/> HIP
<input checked="" type="checkbox"/> SHINGLES	<input type="checkbox"/> GAMBREL
<input type="checkbox"/> SHAKES	<input type="checkbox"/> MANSARD
<input type="checkbox"/> COMPOSITE	<input type="checkbox"/> FLAT

FLOORS	B	1	2	3	U
CONCRETE	<input checked="" type="checkbox"/>	<input type="checkbox"/>	<input type="checkbox"/>	<input type="checkbox"/>	<input type="checkbox"/>
WOOD	<input type="checkbox"/>	<input type="checkbox"/>	<input type="checkbox"/>	<input type="checkbox"/>	<input type="checkbox"/>
TILE/COMPO	<input type="checkbox"/>	<input checked="" type="checkbox"/>	<input checked="" type="checkbox"/>	<input type="checkbox"/>	<input type="checkbox"/>
CARPET	<input type="checkbox"/>	<input checked="" type="checkbox"/>	<input checked="" type="checkbox"/>	<input type="checkbox"/>	<input type="checkbox"/>

INT. FINISH	B	1	2	3	U
PLASTER/DW	<input type="checkbox"/>	<input checked="" type="checkbox"/>	<input checked="" type="checkbox"/>	<input type="checkbox"/>	<input type="checkbox"/>
PANELING	<input type="checkbox"/>	<input type="checkbox"/>	<input type="checkbox"/>	<input type="checkbox"/>	<input type="checkbox"/>
UNFINISHED	<input checked="" type="checkbox"/>	<input type="checkbox"/>	<input type="checkbox"/>	<input type="checkbox"/>	<input type="checkbox"/>

ACCOMMODATIONS	B	1	2	3	U
# OF ROOMS		4	3		
BEDROOMS			3		
FIREPLACES					

HEAT & AC	B	1	2	3	U
NO HEAT	<input type="checkbox"/>	<input type="checkbox"/>	<input type="checkbox"/>	<input type="checkbox"/>	<input type="checkbox"/>
CTRL HEAT	<input type="checkbox"/>	<input checked="" type="checkbox"/>	<input checked="" type="checkbox"/>	<input type="checkbox"/>	<input type="checkbox"/>
HW/STEAM	<input type="checkbox"/>	<input type="checkbox"/>	<input type="checkbox"/>	<input type="checkbox"/>	<input type="checkbox"/>
ELECTRIC	<input type="checkbox"/>	<input type="checkbox"/>	<input type="checkbox"/>	<input type="checkbox"/>	<input type="checkbox"/>
HEAT PUMP	<input type="checkbox"/>	<input type="checkbox"/>	<input type="checkbox"/>	<input type="checkbox"/>	<input type="checkbox"/>
FLR/WALL	<input type="checkbox"/>	<input type="checkbox"/>	<input type="checkbox"/>	<input type="checkbox"/>	<input type="checkbox"/>
STVE/SPCE	<input type="checkbox"/>	<input type="checkbox"/>	<input type="checkbox"/>	<input type="checkbox"/>	<input type="checkbox"/>
GEO THERMAL	<input type="checkbox"/>	<input type="checkbox"/>	<input type="checkbox"/>	<input type="checkbox"/>	<input type="checkbox"/>
OUTSIDE	<input type="checkbox"/>	<input type="checkbox"/>	<input type="checkbox"/>	<input type="checkbox"/>	<input type="checkbox"/>
CTRL A/C	<input type="checkbox"/>	<input checked="" type="checkbox"/>	<input checked="" type="checkbox"/>	<input type="checkbox"/>	<input type="checkbox"/>

FLOOR	AREA	CONST	VALUE
1	1676	BRK	96240
2ND	572	FR	23020
BSMT			1188
SUBTOTAL			134700
MULTI-FAMILY #			
BSMT FINISH S.F.			
FIREPLACE #			
HEATING S.F.			
AIR COND 2248 S.F.			
PLUMBING # 6			
GARAGES & CARPORTS			
EXTRA FEATURES			
SUBTOTAL			166870
GRADE FACTOR			140 %
UNADJUSTED VALUE			233620
FACTOR			100 %

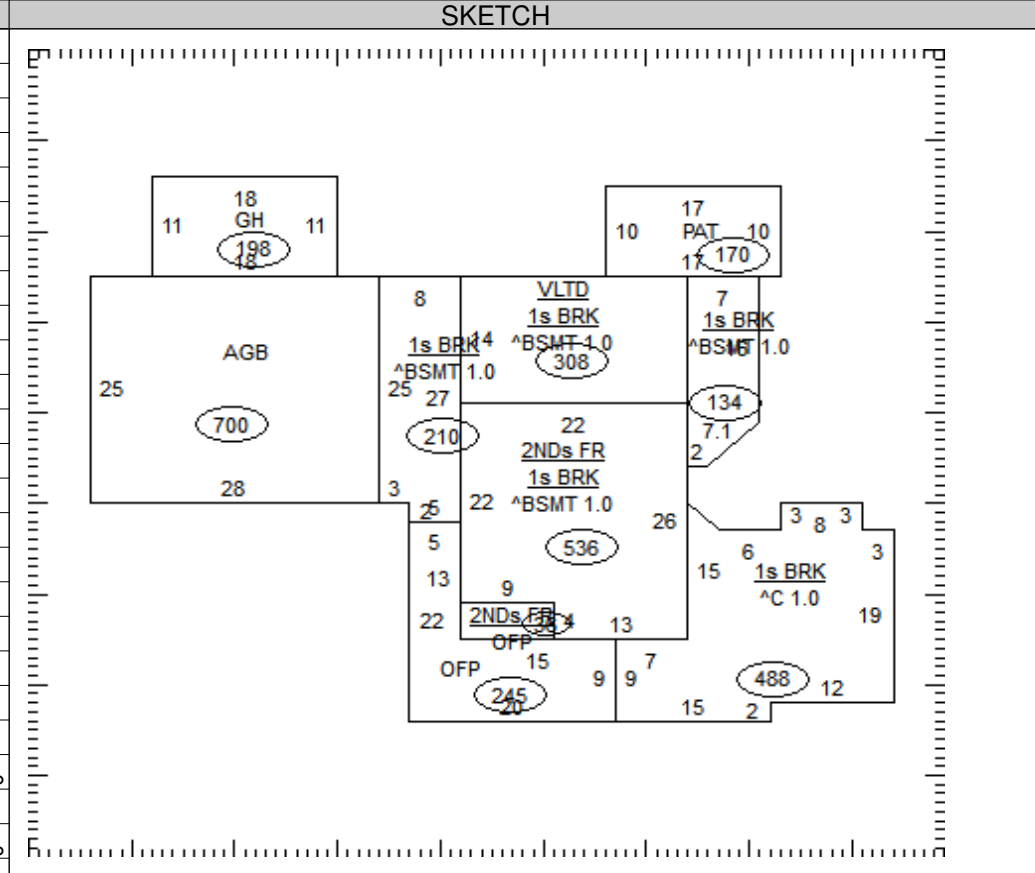

OCCUPANCY	ST.HT	SIZE	AREA	GRADE	PRICE	AGE	REMD	CND	UNADJ VAL	PHYS	PHYS VAL	FUNC	TRUE VAL
DWELLING	2	SK	2248	B+		1997		A	233620	13	203250		203300
1 Greenhouse		11x18	198	C	10.00				1980	100			0
2													
3													
4													
5													
6													
7													
8													
9													
10													
11													

05-178800.0000 TOTAL 203300

COMMENTS