

\*05-012551.0119\*

**BRUNS DALE L & DEBRA J**

BRUNS DALE L & DEBRA J  
605 ROBERT ST  
COLDWATER, OH 45828

**LEGAL INFORMATION**

WENNING ACRES FOURTH ADDITION

LOT#: 1658

Created in 2009 From 05-012551.0100 due to Split

	OWNERSHIP	MAILING ADDRESS	CITY	STATE	ZIP	DATE	AMOUNT	CONV #	JS	VALID
1	BRUNS DALE L & DEBRA J	605 ROBERT ST	COLDWATER	OH	45828	05/12/2010	34300	WDC : A : 285	<input type="checkbox"/>	<input checked="" type="checkbox"/>
2	WENNING ACRES INC	706 N SECOND ST	COLDWATER	OH	45828	11/24/2009	0	: : 0	<input type="checkbox"/>	<input type="checkbox"/>
3							0		<input type="checkbox"/>	<input type="checkbox"/>

X: LISTER: CG DATE: 08/11/2011 TIME: 12:00:00 AM  LETTER  LETTER REC'D GIS CODE

STREET/ROAD	TOPOGRAPHY	PU-UTILITIES-PR	NEIGHBORHOOD	INFLUENCE FACTORS	PROPERTY LOCATION	
<input type="checkbox"/> PAVED <input type="checkbox"/> GRAVEL <input type="checkbox"/> DIRT <input type="checkbox"/> SIDEWALKS <input type="checkbox"/> CURBS	<input type="checkbox"/> LEVEL <input type="checkbox"/> HIGH <input type="checkbox"/> LOW <input type="checkbox"/> ROLLING <input type="checkbox"/> STANDARD	<input type="checkbox"/> WATER <input type="checkbox"/> SEWER <input type="checkbox"/> GAS <input type="checkbox"/> ELECTRIC <input type="checkbox"/> STANDARD	<input type="checkbox"/> IMPROVING <input type="checkbox"/> STATIC <input type="checkbox"/> DECLINING <input type="checkbox"/> OLD <input type="checkbox"/> STANDARD	<input type="checkbox"/> A. NO ROAD <input type="checkbox"/> B. TOPGRHY <input type="checkbox"/> C. EX FRONT <input type="checkbox"/> D. QUANTITY <input type="checkbox"/> E. SZ/SHAPE	<input type="checkbox"/> F. RESTRICT <input type="checkbox"/> G. WOOD LT <input type="checkbox"/> H. VACANCY <input type="checkbox"/> I. WATER FRONT <input type="checkbox"/> J. OTHER/CDU	605 ROBERT ST, COLDWATER

**COMMENT**  
NC12 REMOVE INC/ NO FIELD CHECK NEEDED  
DE11 ADD NEW DWLG, RMV VAC, RMV QUANTITY  
DE10 ALLOW 30% QUANTITY  
TY2011:Net Gen=\$3,758.40, Net Spec=\$0.00

LAND COMPUTATIONS							
CODES:	LAND TYPE	SIZE	M	RATE	C	INF	M VALUE C
F: FRONT R: REAR	FR:F	F121 D141	ST280	DP96	ADJ269		32500 0
HS: HOME SITE							
SM: SMALL ACRE							
WA: WASTE							
RD: ROAD							
EA: EASEMENT							
<b>TOTAL</b>							32500 0

**VALUATION SUMMARY**

ASSESSMENT YEAR	2011	2011	2011	2011	2010	2010	2010	2010
REASON FOR CHANGE	NC	RCLS	RAPP	MISC	MISC	MISC	RCLS	MISC
APPRAISED VALUE	LAND 32500	32500	17100	15200	21800	15200	0	0
	IMPR 226900	0	0	0	0	0	0	0
	TOTAL 259400	32500	17100	15200	21800	15200	0	0
ASSESSED VALUE	LAND 11380	11380	5990	5320	7630	5320	0	0
	IMPR 79420	0	0	0	0	0	0	0
	TOTAL 90800	11380	5990	5320	7630	5320	0	0

OCCUPANCY	EXTERIOR	FLOOR	AREA	CONST	VALUE
<input checked="" type="checkbox"/> SNGL FMLY <input type="checkbox"/> DUPLEX <input type="checkbox"/> TRIPLEX <input type="checkbox"/> CONVR <input type="checkbox"/> MOBILE HM <input type="checkbox"/> BI/L TRI/L <input type="checkbox"/> MOD/MAN	<input type="checkbox"/> WOOD <input type="checkbox"/> STUCCO <input type="checkbox"/> ALM/VYNL <input type="checkbox"/> CONC BLK <input type="checkbox"/> METAL <input checked="" type="checkbox"/> BRICK <input type="checkbox"/> STONE	1	2583	BRK	143330

ROOFING	ROOF TYPE
<input type="checkbox"/> METAL <input type="checkbox"/> SLT/TLE <input checked="" type="checkbox"/> SHINGLES <input type="checkbox"/> SHAKES <input type="checkbox"/> COMPOSITE	<input type="checkbox"/> GABLE <input checked="" type="checkbox"/> HIP <input type="checkbox"/> GAMBREL <input type="checkbox"/> MANSARD <input type="checkbox"/> FLAT

FLOORS	B	1	2	3	U
CONCRETE	<input type="checkbox"/>	<input type="checkbox"/>	<input type="checkbox"/>	<input type="checkbox"/>	<input type="checkbox"/>
WOOD	<input type="checkbox"/>	<input type="checkbox"/>	<input type="checkbox"/>	<input type="checkbox"/>	<input type="checkbox"/>
TILE/COMPO	<input type="checkbox"/>	<input checked="" type="checkbox"/>	<input type="checkbox"/>	<input type="checkbox"/>	<input type="checkbox"/>
CARPET	<input type="checkbox"/>	<input checked="" type="checkbox"/>	<input type="checkbox"/>	<input type="checkbox"/>	<input type="checkbox"/>

  

INT. FINISH	B	1	2	3	U
PLASTER/DW	<input type="checkbox"/>	<input checked="" type="checkbox"/>	<input type="checkbox"/>	<input type="checkbox"/>	<input type="checkbox"/>
PANELING	<input type="checkbox"/>	<input type="checkbox"/>	<input type="checkbox"/>	<input type="checkbox"/>	<input type="checkbox"/>
UNFINISHED	<input checked="" type="checkbox"/>	<input type="checkbox"/>	<input type="checkbox"/>	<input type="checkbox"/>	<input type="checkbox"/>

ACCOMMODATIONS					
# OF ROOMS	6				
BEDROOMS	3				
FIREPLACES					
HEAT & AC	B	1	2	3	U
NO HEAT	<input type="checkbox"/>	<input type="checkbox"/>	<input type="checkbox"/>	<input type="checkbox"/>	<input type="checkbox"/>
CTRL HEAT	<input type="checkbox"/>	<input checked="" type="checkbox"/>	<input type="checkbox"/>	<input type="checkbox"/>	<input type="checkbox"/>
HW/STEAM	<input type="checkbox"/>	<input type="checkbox"/>	<input type="checkbox"/>	<input type="checkbox"/>	<input type="checkbox"/>
ELECTRIC	<input type="checkbox"/>	<input type="checkbox"/>	<input type="checkbox"/>	<input type="checkbox"/>	<input type="checkbox"/>
HEAT PUMP	<input type="checkbox"/>	<input type="checkbox"/>	<input type="checkbox"/>	<input type="checkbox"/>	<input type="checkbox"/>
FLR/WALL	<input type="checkbox"/>	<input type="checkbox"/>	<input type="checkbox"/>	<input type="checkbox"/>	<input type="checkbox"/>
STVE/SPCE	<input type="checkbox"/>	<input type="checkbox"/>	<input type="checkbox"/>	<input type="checkbox"/>	<input type="checkbox"/>
GEO THERMAL	<input type="checkbox"/>	<input type="checkbox"/>	<input type="checkbox"/>	<input type="checkbox"/>	<input type="checkbox"/>
OUTSIDE	<input type="checkbox"/>	<input type="checkbox"/>	<input type="checkbox"/>	<input type="checkbox"/>	<input type="checkbox"/>
CTRL A/C	<input type="checkbox"/>	<input checked="" type="checkbox"/>	<input type="checkbox"/>	<input type="checkbox"/>	<input type="checkbox"/>

OCCUPANCY	ST.HT	SIZE	AREA	GRADE	PRICE	AGE	REMD	CND	UNADJ VAL	PHYS	PHYS VAL	FUNC	TRUE VAL
DWELLING	1	SK	2583	C+		2010		G	236260	2	231530	INC2	226900
1													
2													
3													
4													
5													
6													
7													
8													
9													
10													
11													

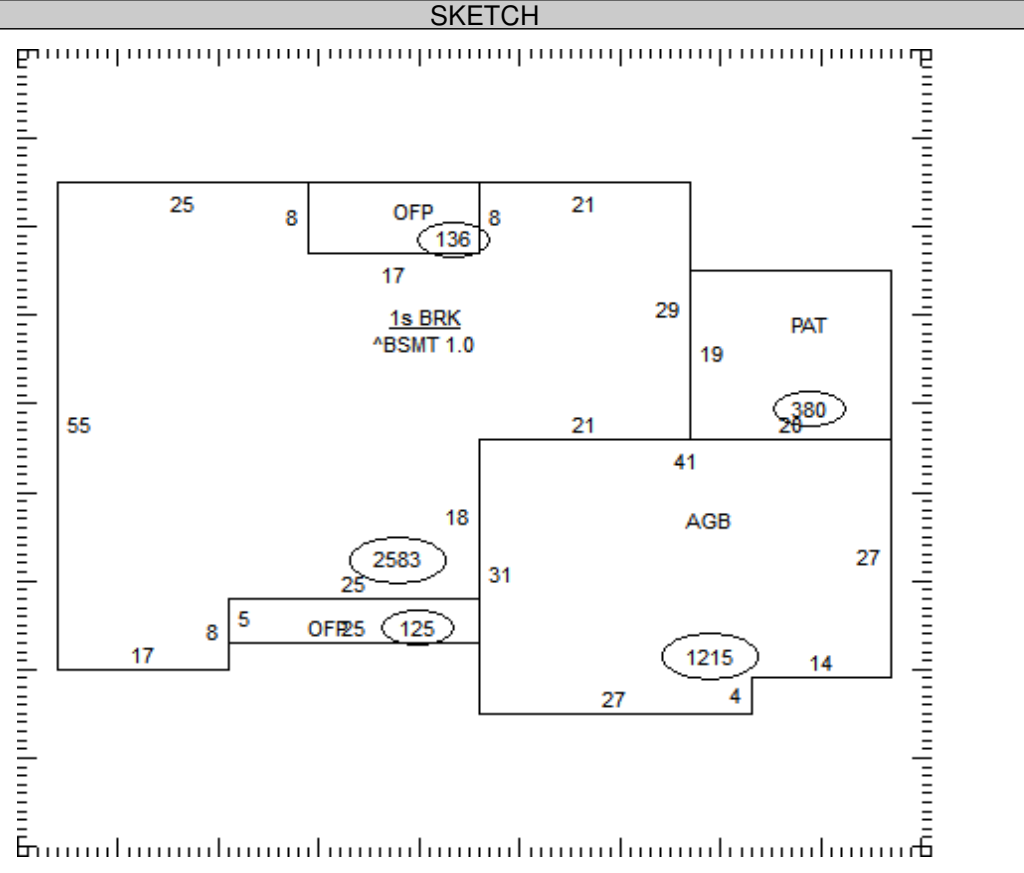

05-012551.0119 TOTAL 226900

COMMENTS