

1123100002

Steinlage Survey

Part of the E 1/2 of the NW 1/4
Section 23, T7S, R2E
Granville Twp., Mercer County, Ohio

Basis of bearing on Kremer-Hoying Rd
is from Mercer County GPS records.



Scale: 1" = 100'
0 50 100 200

~ Legend ~

- ⊕ 2 1/2" Mag Nail set
- Iron pin w/cap set
- △ Section Corner

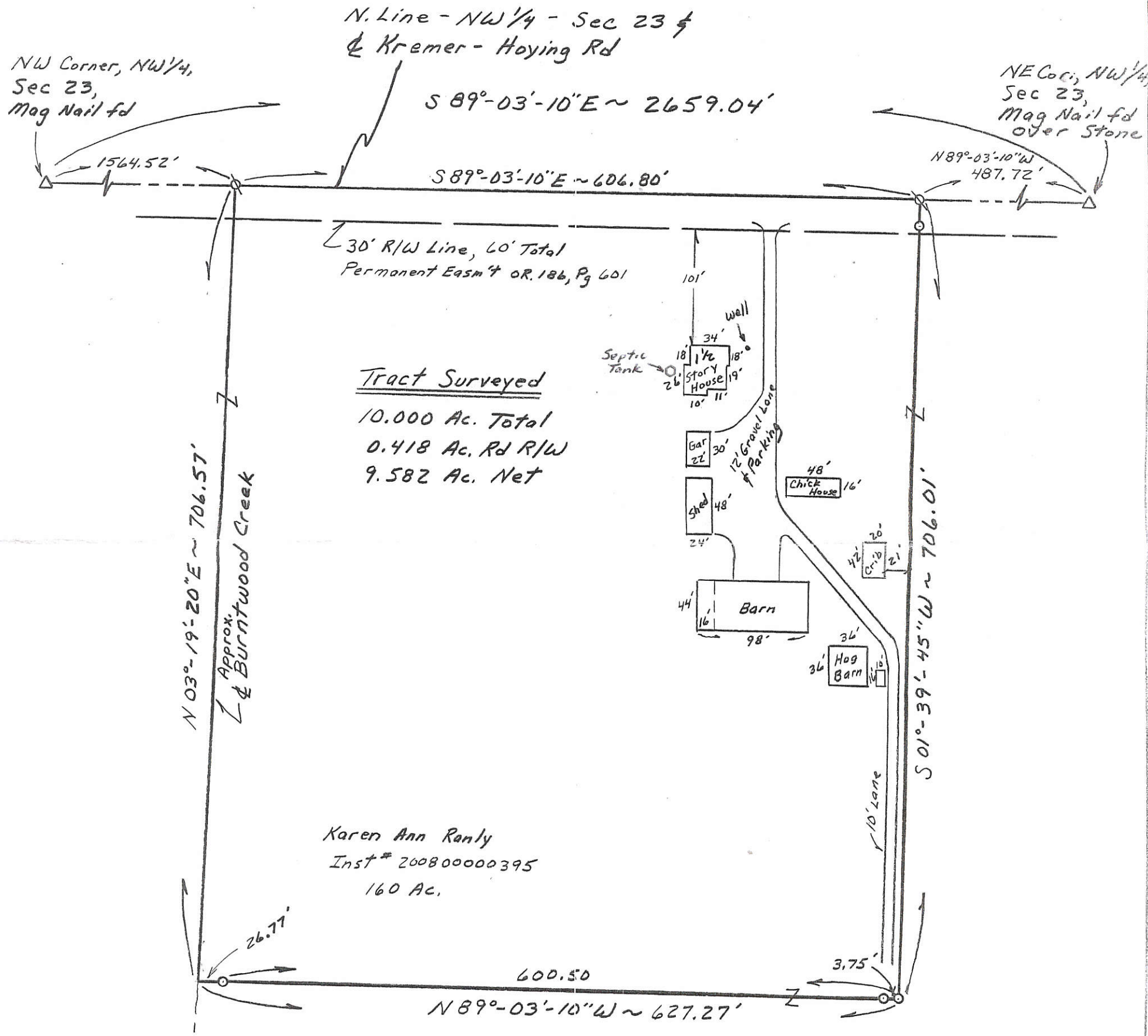
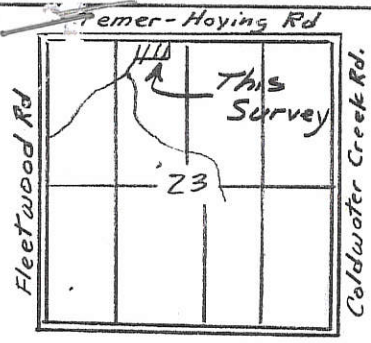

Approved by the Mercer
County Regional Planning
Commission; no plat
required under
R.C. 711.133

Approvals

Vernon C. Eihler Date 3-27-08
Mercer County Engineer

Thomas Schmitz Date 3-24-08
Township Zoning Officer

Chi M Date 3-28-08
Board of Health

Survey Completed March 15, 2008

Steven H. Kremer
By Steven H. Kremer
New Bremen, Ohio
Registered Surveyor No. 7487

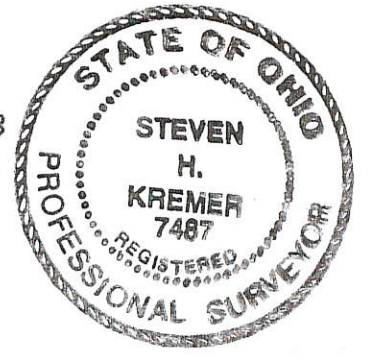

LEGEND

- △ = CORNERSTONE (REFER TO MERCER COUNTY STONE RECORDS).
- ⊗ = SPINDLE SET.
- ⊙ = 5/8 INCH IRON BAR SET.

1123100004, -003, -006, -005

SURVEYED BY

James W. Geeslin

JAMES W. GEESLIN

P.S. No. 7764

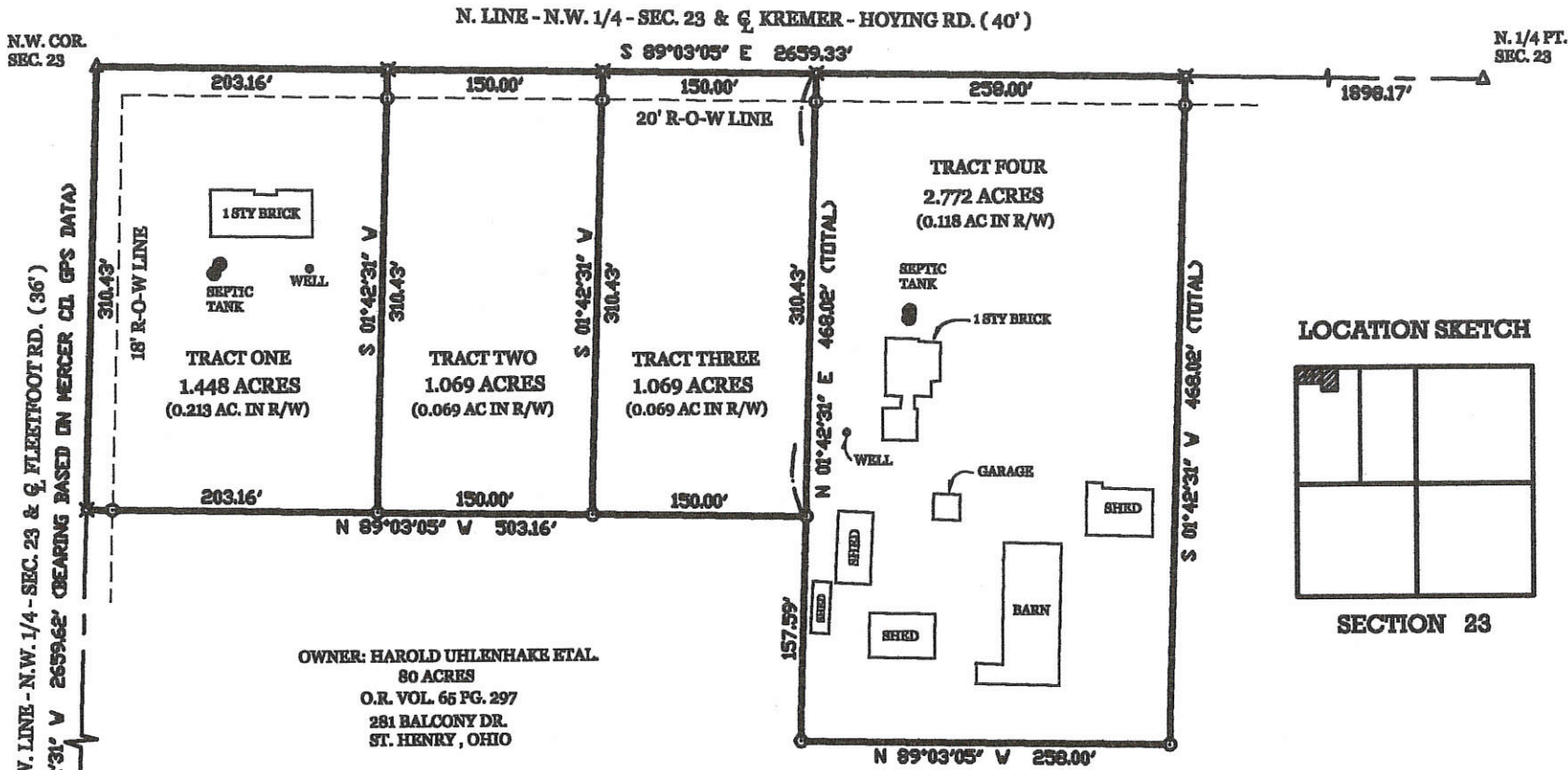
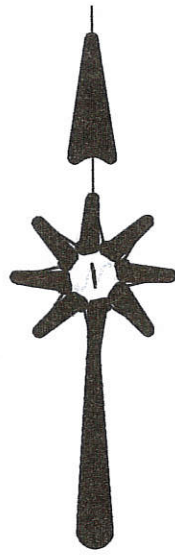

OWNER: HAROLD UHLENHAKE ETAL
80 ACRES
O.R. VOL. 66 PG. 297
281 BALCONY DR.
ST. HENRY, OHIO

LOCATION SKETCH

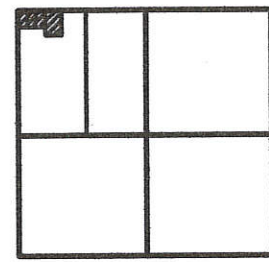

SECTION 23

UHLENHAKE SURVEY

PART OF THE W. 1/2 OF THE N.W. 1/4 OF SECTION 23, TOWN 7 SOUTH, RANGE 2 EAST,
(GRANVILLE TOWNSHIP), MERCER COUNTY, OHIO.

NOVEMBER 12, 2001

SCALE 1" = 100'



PERMANENT
PARCEL No.

Part of: _____ Township
Sec. _____ Range _____
Grantor: _____ Area Retained: _____ Acres
Grantee: _____ Area Transferred: _____ Acres
Deed References: _____

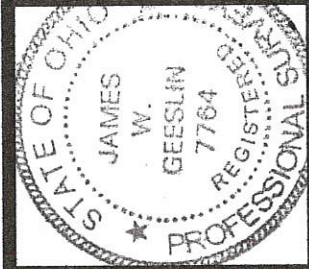

**GEESLIN
LAND SURVEYING**

P.O. BOX 422
CELINA, OHIO
PHONE (419) 586-6155
FAX (419) 268-0554

APPROVALS
DATE

Board of Health

Township Zoning Officer

County Engineer

RANLY PROPERTY

PROJECT # 214808.18

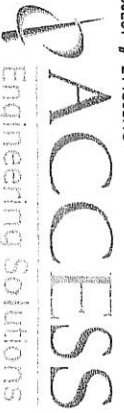

1200 IRMSCHER BLVD., SUITE B, CELINA, OH 45822
www.accesseng.com 419-586-1430

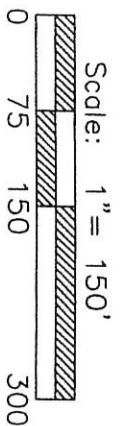
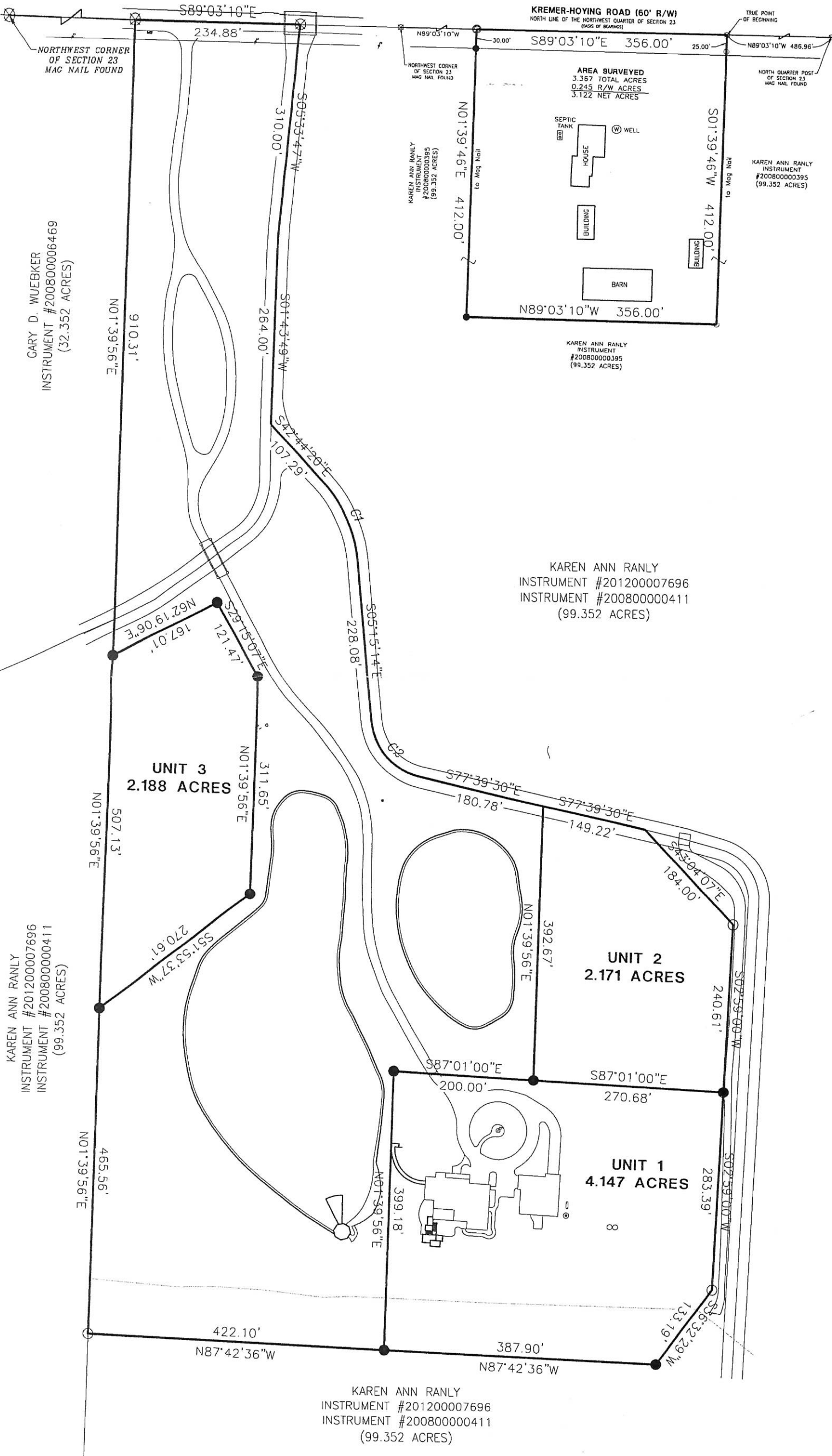

1123100008

SURVEY FOR KAREN ANN RANLY

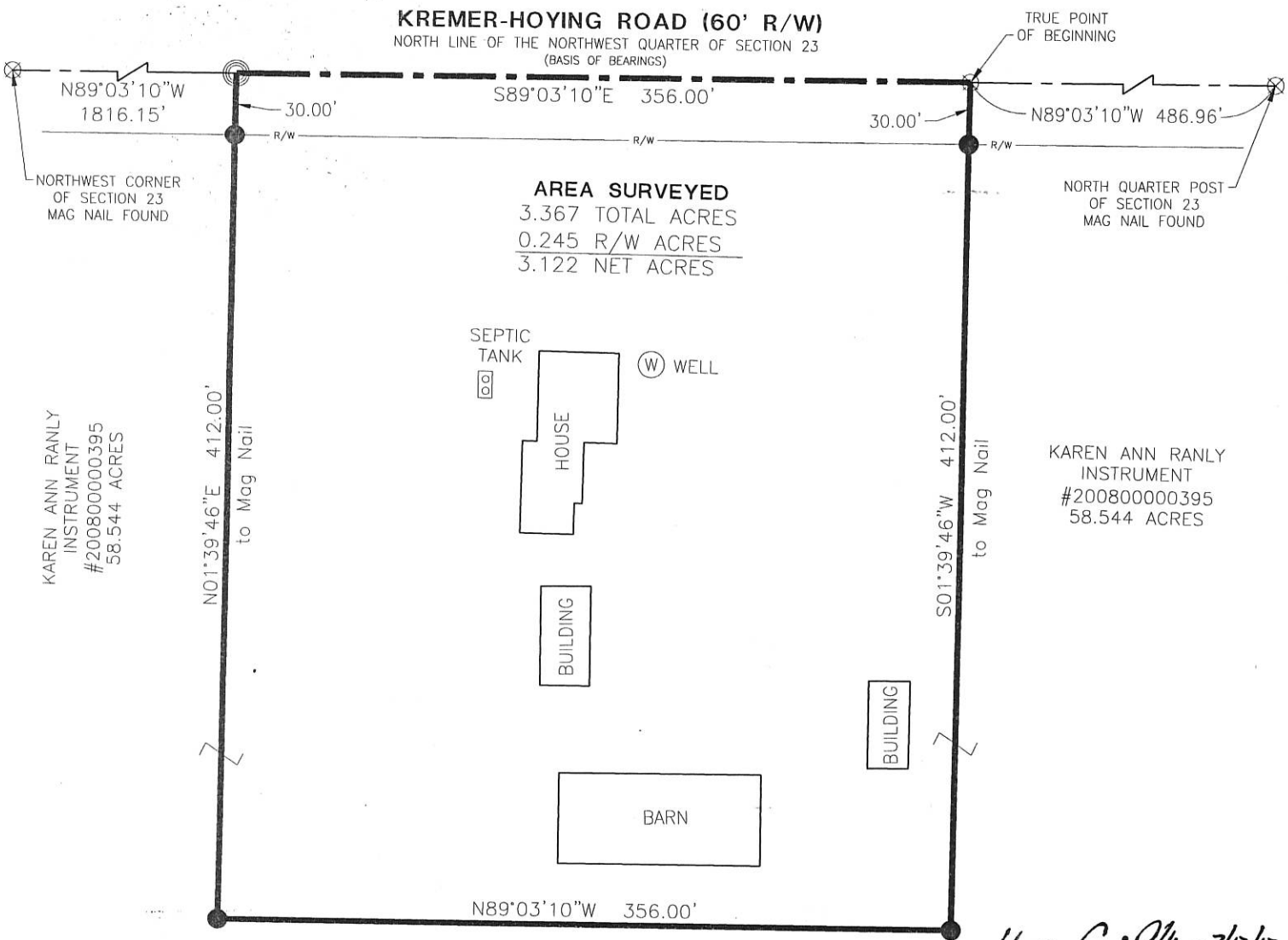

AREA SURVEYED
 3.367 TOTAL ACRES
 0.245 R/W ACRES
 3.122 NET ACRES

KAREN ANN RANLY
 INSTRUMENT
 #200800000395
 58.544 ACRES

KAREN ANN RANLY
 INSTRUMENT
 #200800000395
 58.544 ACRES

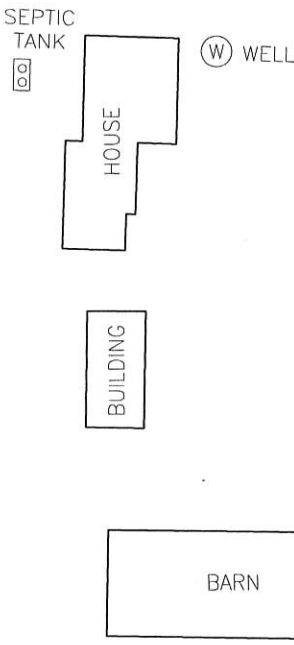

1 Lot Cal Plan 7/13/17
MINOR SUBDIVISION
 Approved No Plat Required
 For A Major Subdivision

PAID

JUL 13 2017

Mercer Co. Health Dept.

PAID

JUL 13 2017

\$20.00 - 1 Lot
 MERCER COUNTY COMMISSIONERS
 CELINA, OHIO
J. Nagal

LEGEND

- ⊗ RR Spike Found
- Iron Pin Found
- Iron Pin Set
- ⊙ Mag Nail Set
- ⊗ Mag Nail Found
- Con Mon. Found
- △ Section Corner

Aaron Moeller 7-12-17
 County Engineer

[Signature] 7-13-17
 Health Department

[Signature]
 Zoning Inspector

Surveyed By: *[Signature]*
 Craig W. Mescher Reg. Surveyor No. 8237

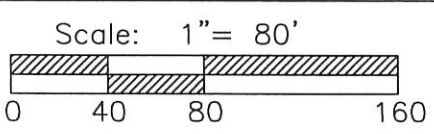
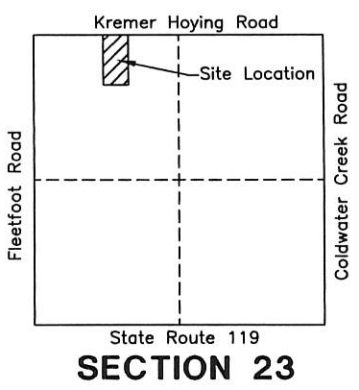

References:
 Bearings from Survey by Craig W. Mescher P.S.# 8237 in April of 2010.
 Mercer County Coordinate Datum

State of: Ohio County: Mercer
 Township: Granville
 Sec.: 23 Town: 7S Range: 2E
 Deed Ref.: Instrument #200800000395
 Date Surveyed: June 24, 2017

PROJECT # 216808.81

1200 IRMSCHER BLVD., SUITE B, CELINA, OH 45822
 www.accessengllc.com | 419-586-1430

~ Legend ~

- Iron pin w/ cap set
- Iron pin w/ cap fd
- ⊗ Mag nail set in Bridge Deck
- ⊙ Mag nail fd.

Scale: 1" = 200'



Wuebker Survey 1123100002 N

Tract being Part of the W¹/₂ of the NW¹/₄ of Section 23, Granville Twp., T7S, R2E, Mercer County, Ohio

Basis of Brq for Survey from County GPS Records along Fleetfoot Rd.

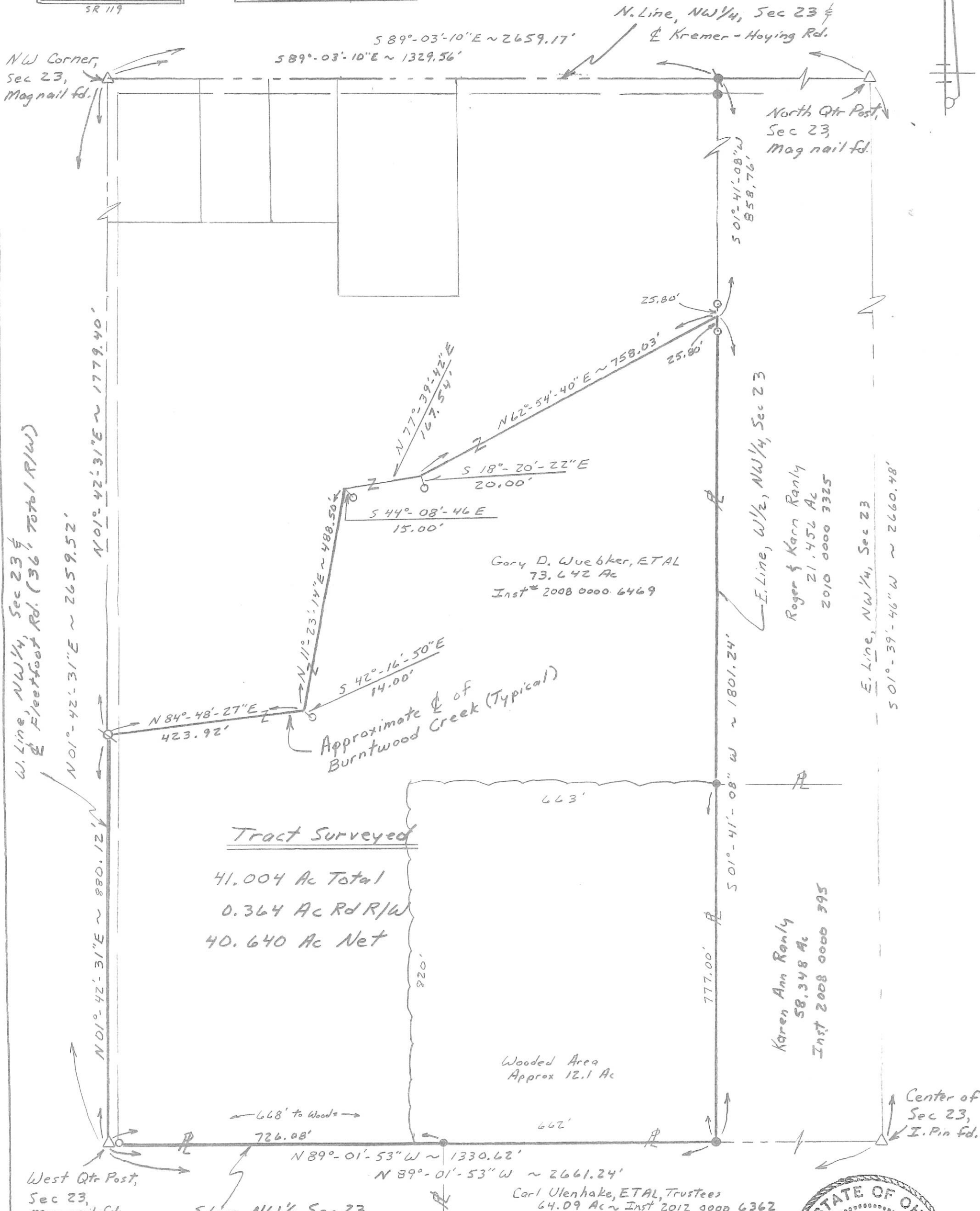
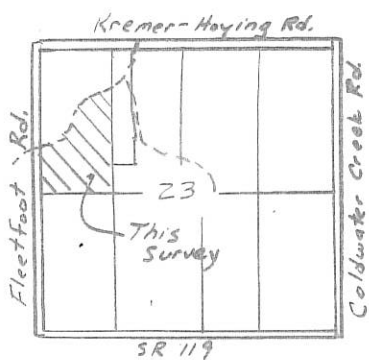

Tract Surveyed
 41.004 Ac Total
 0.364 Ac Rd R/W
 40.640 Ac Net

Gary D. Wuebker, ETAL
 73.642 Ac
 Inst# 2008 0000 6469

Roger & Karn Ranly
 21.456 Ac
 2010 0000 3325

Karen Ann Ranly
 58.348 Ac
 Inst 2008 0000 395

Wooded Area
 Approx 12.1 Ac

Frank & Irene Meyer
 5.000 Ac
 Inst# 2006 0000 4423

Carl Ulenhake, ETAL, Trustees
 64.09 Ac ~ Inst 2012 0000 6362

Survey Completed Nov 9, 2012

By: Steven H. Kremer
 New Bremen, Ohio
 Registered Surveyor No 7487



Plot Ref: Survey dated 4-14-10 by Surveyor# 8237
 Survey dated 11-12-01 by Surveyor# 7764

SURVEY FOR KAREN ANN RANLY

1123100007

BEING A PARCEL OF LAND LOCATED IN THE EAST HALF OF THE NORTHWEST QUARTER OF SECTION 23, GRANVILLE TOWNSHIP, TOWN 7 SOUTH, RANGE 2 EAST, MERCER COUNTY, OHIO.

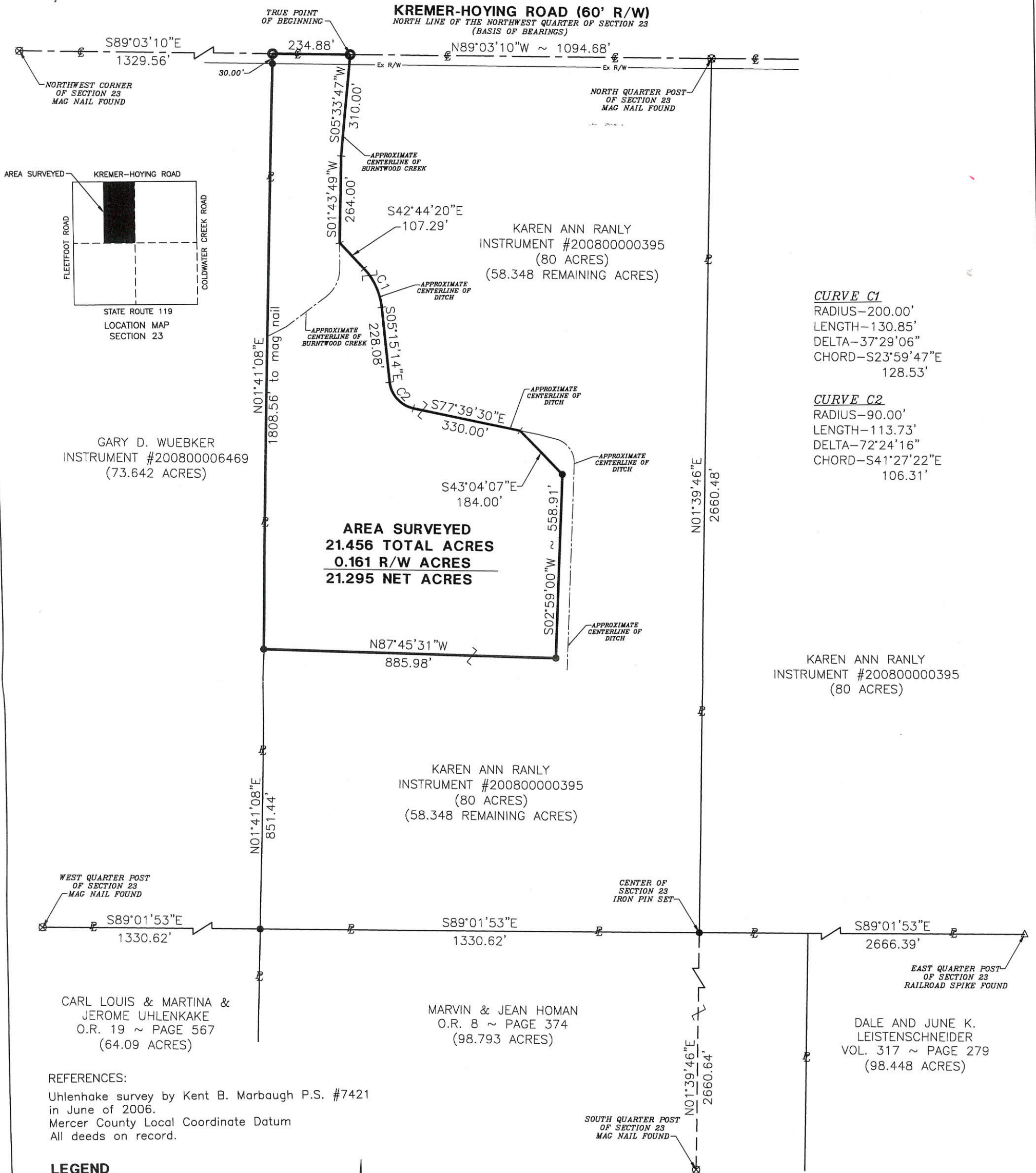

CURVE C1
 RADIUS-200.00'
 LENGTH-130.85'
 DELTA-37°29'06"
 CHORD-S23°59'47"E
 128.53'

CURVE C2
 RADIUS-90.00'
 LENGTH-113.73'
 DELTA-72°24'16"
 CHORD-S41°27'22"E
 106.31'

AREA SURVEYED
21.456 TOTAL ACRES
0.161 R/W ACRES
21.295 NET ACRES

KAREN ANN RANLY
 INSTRUMENT #200800000395
 (80 ACRES)

KAREN ANN RANLY
 INSTRUMENT #200800000395
 (80 ACRES)
 (58.348 REMAINING ACRES)

GARY D. WUEBKER
 INSTRUMENT #200800006469
 (73.642 ACRES)

CARL LOUIS & MARTINA &
 JEROME UHLENKAKE
 O.R. 19 ~ PAGE 567
 (64.09 ACRES)

MARVIN & JEAN HOMAN
 O.R. 8 ~ PAGE 374
 (98.793 ACRES)

DALE AND JUNE K.
 LEISTENSCHNEIDER
 VOL. 317 ~ PAGE 279
 (98.448 ACRES)

REFERENCES:
 Uhlenhake survey by Kent B. Marbaugh P.S. #7421
 in June of 2006.
 Mercer County Local Coordinate Datum
 All deeds on record.

LEGEND

- Iron Pin Found
- Iron Pin Set
- ⊙ Mag Nail Set
- ⊗ Mag Nail Found
- △ Railroad Spike Found

SCALE: 1" = 300'

Health Department

[Signature]
 Zoning Inspector

County Engineer

Surveyed By: *[Signature]*
 Craig W. Mescher Reg. Surveyor No. 8237
 Date: 04-14-10



11-F(23)

1123300014

LEGEND

- = MAG NAIL FOUND OVER CORNERSTONE .
- = 5/8 INCH IRON BAR FOUND.
- ⊙ = MAG NAIL FOUND .
- ⊙ = 5/8 INCH IRON BAR SET.

LOCATION SKETCH

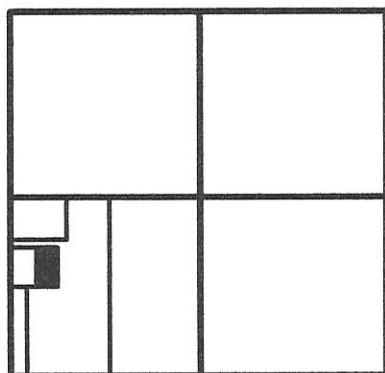

SECTION 23

W. 1/4 POST - SEC. 23

SURVEY REFERENCES :

- 1) K. MARBAUGH, P.S. 7421, DATED 7-10-04 AND 1-21-12 .
- 2) PRIOR SURVEY DATED 1-14-16 .

5.50 ACRE PARCEL

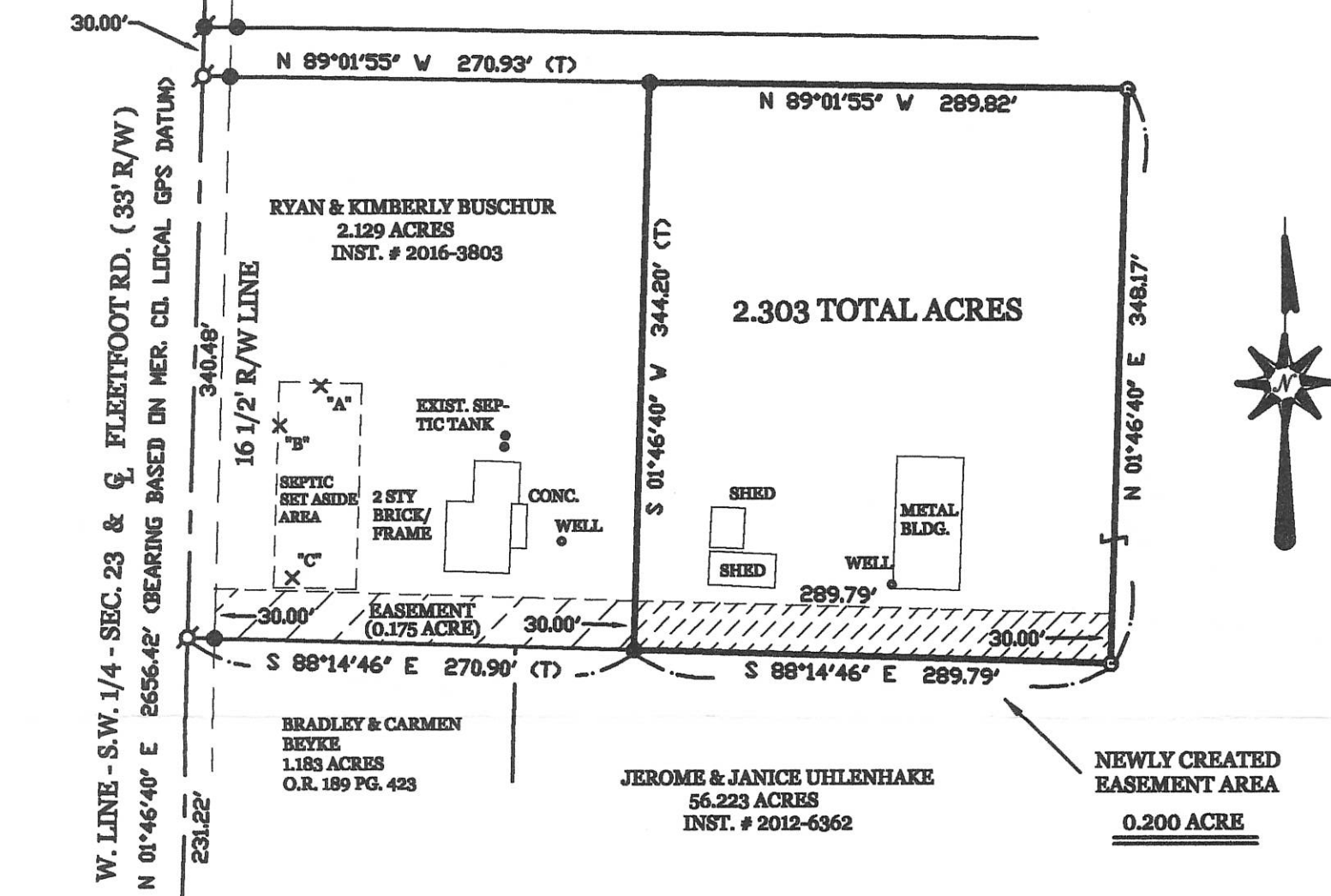

SURVEYED BY

James W. Geeslin

 JAMES W. GEESLIN
 P.S. No. 7764

UHLENHAKE SURVEY

PART OF THE W. 1/2 - S.W. 1/4 - SEC. 23, TOWN 7 SOUTH,
 RANGE 2 EAST, (GRANVILLE TOWNSHIP), MERCER COUNTY,
 OHIO .

JUNE 27, 2017

SCALE 1" = 100'

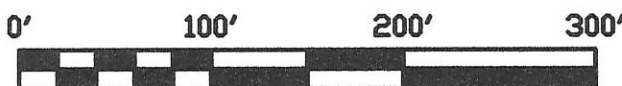

S.W. COR. - SEC. 23

GEESLIN LAND SURVEYING

525 S. SECOND ST.
 COLDWATER, OHIO 45828
 PHONE (419) 678-7232

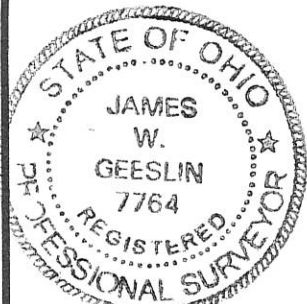

PERMANENT PARCEL No. _____

Part of: _____ Sec. _____ T _____ R _____ Township

Grantor: _____ Area Retained: _____ Acres

Grantee: _____ Area Transferred: _____ Acres

Deed References: _____

APPROVALS:	Board of Health	Township Zoning Officer	County Engineer
AGENCY:			
DATE:			

11-F(23)

1123300011

Legend:

- ▲ Cornerstone @ the W1/4 post of Section 23
- ▲ Cornerstone @ the SW corner of Section 23
- Mag nail set
- 5/8" X 30" Iron pin w/cap set
- ⊙ 5/8" X 30" Iron pin w/cap set on line and 20.0' from corner
- ▲ E1/4 post of Section 23 (Set by Gordon Geeslin)

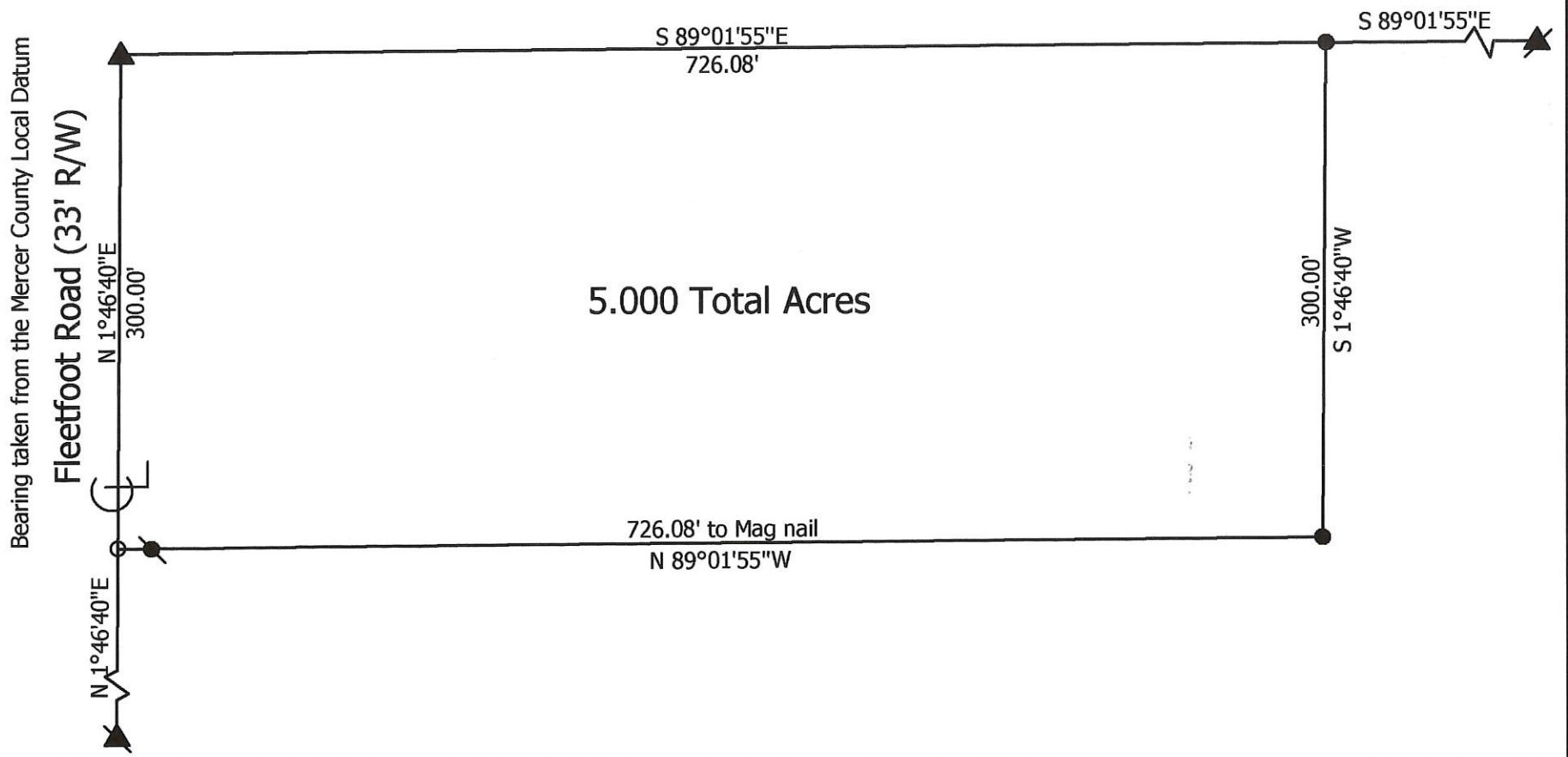
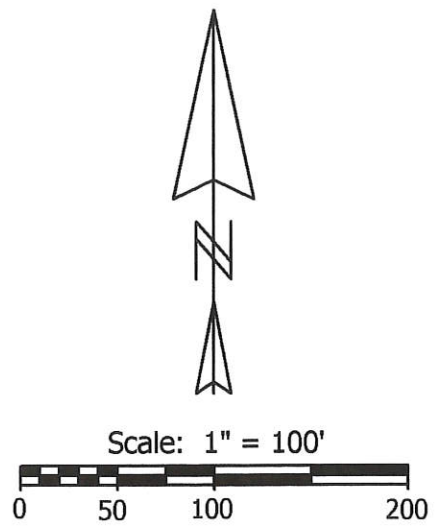
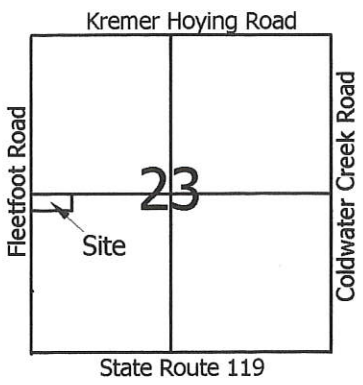

Marbaugh Land Surveying
 1210 Yorkshire Court
 Celina, Ohio 45822
 (419) 586-4293

Kent B. Marbaugh
 Kent B. Marbaugh P.S. 7421



Uhlenhake Survey

State of: Ohio County: Mercer
 Township: Granville Sec: 23 Town: 7S Range: 2E
 City/Village: _____ Subdivision: _____ Lot: _____
 Deed Ref: Vol. 313, Pg. 735 Date Surveyed: 6-15-06

Approvals:
 Agency: _____ Board of Health _____ Township Zoning Inspector _____ County Engineer _____
 Date: _____

11-F ✓

1123300010

11-F

LEGEND

LOCATION SKETCH

"A" = COR. STONE @ S.E. COR. ~ S.W. 1/4 ~ SEC. 23.

"B" = COR. STONE @ S.W. COR. ~ SEC. 23.

● = "P.K." NAIL SET.

○ = 5/8" X 30" IRON BAR SET.

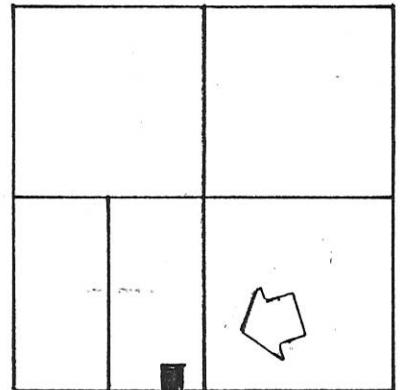

SECTION 23

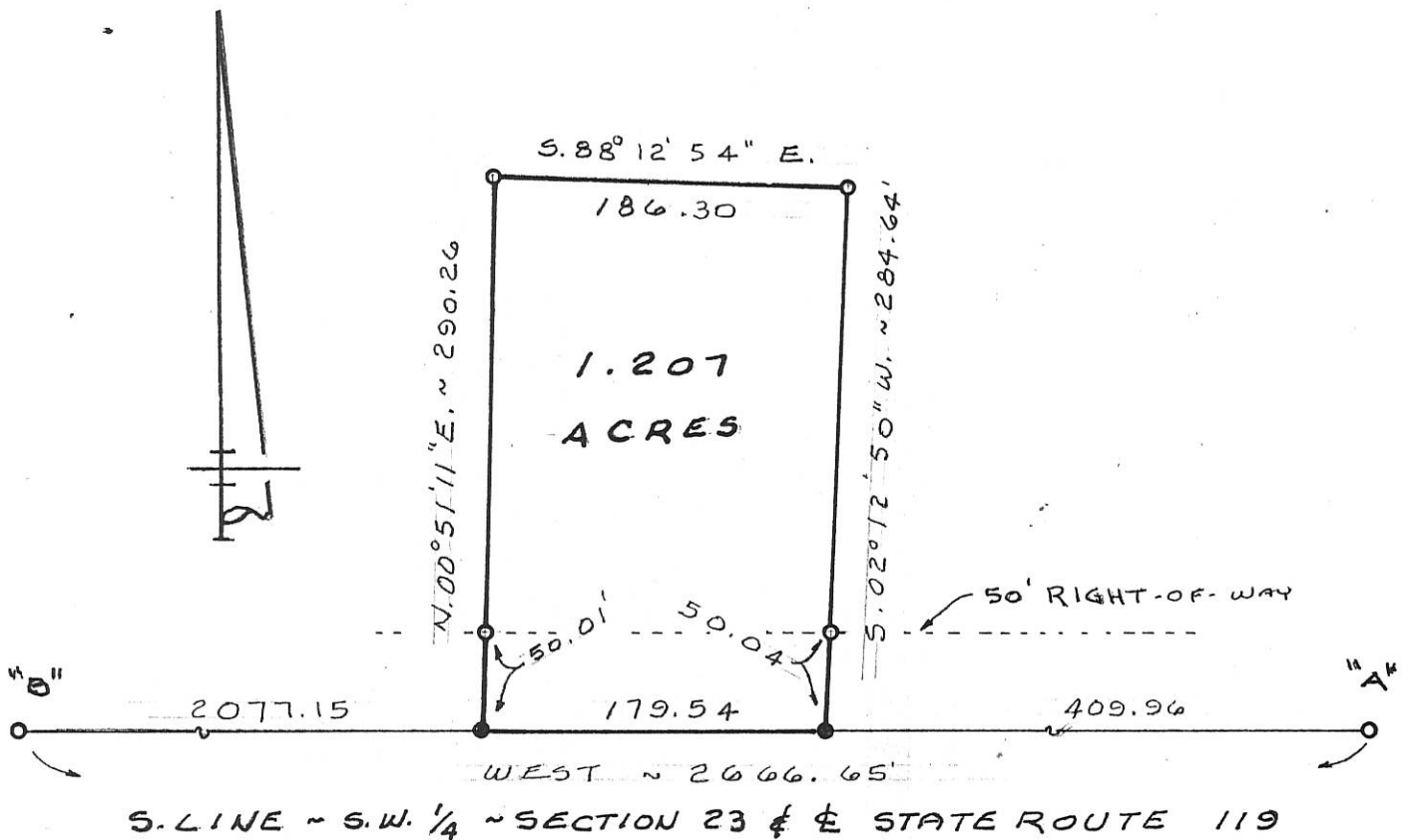

S. LINE ~ S.W. 1/4 ~ SECTION 23 & STATE ROUTE 119

SURVEYED BY Gordon L. Geeslin

GORDON L. GEESLIN
REGISTERED SURVEYOR
NO 5372

H O M A N S U R V E Y

PART OF THE 1/2 OF THE S.W. 1/4 OF SECTION 23,
TOWN 7 SOUTH, RANGE 2 EAST (GRANVILLE
TWP.), MERCER COUNTY, OHIO.

APRIL 30, 1996



SCALE 1" = 100'

**GEESLIN
LAND SURVEYING**

810 EAST MARKET STREET

CELINA, OHIO

PHONE (419) 586-6155



PERMANENT PARCEL No. _____

Part of: _____ Sec. _____ T _____ R _____ Township

Grantor: _____ Area Retained: _____ Acres

Grantee: _____ Area Transferred: _____ Acres

Deed References: _____

APPROVALS:
AGENCY: _____ DATE: _____ Board of Health _____ County Sanitary Engineer _____ County Engineer _____

1123300011

- Legend:**
- ▲ Cornerstone @ the W1/4 post of Section 23
 - ▲ Cornerstone @ the SW corner of Section 23
 - Mag nail set
 - 5/8" X 30" Iron pin w/cap set
 - 5/8" X 30" Iron pin w/cap set on line and 20.0' from corner
 - ▲ E1/4 post of Section 23 (Set by Gordon Geeslin)

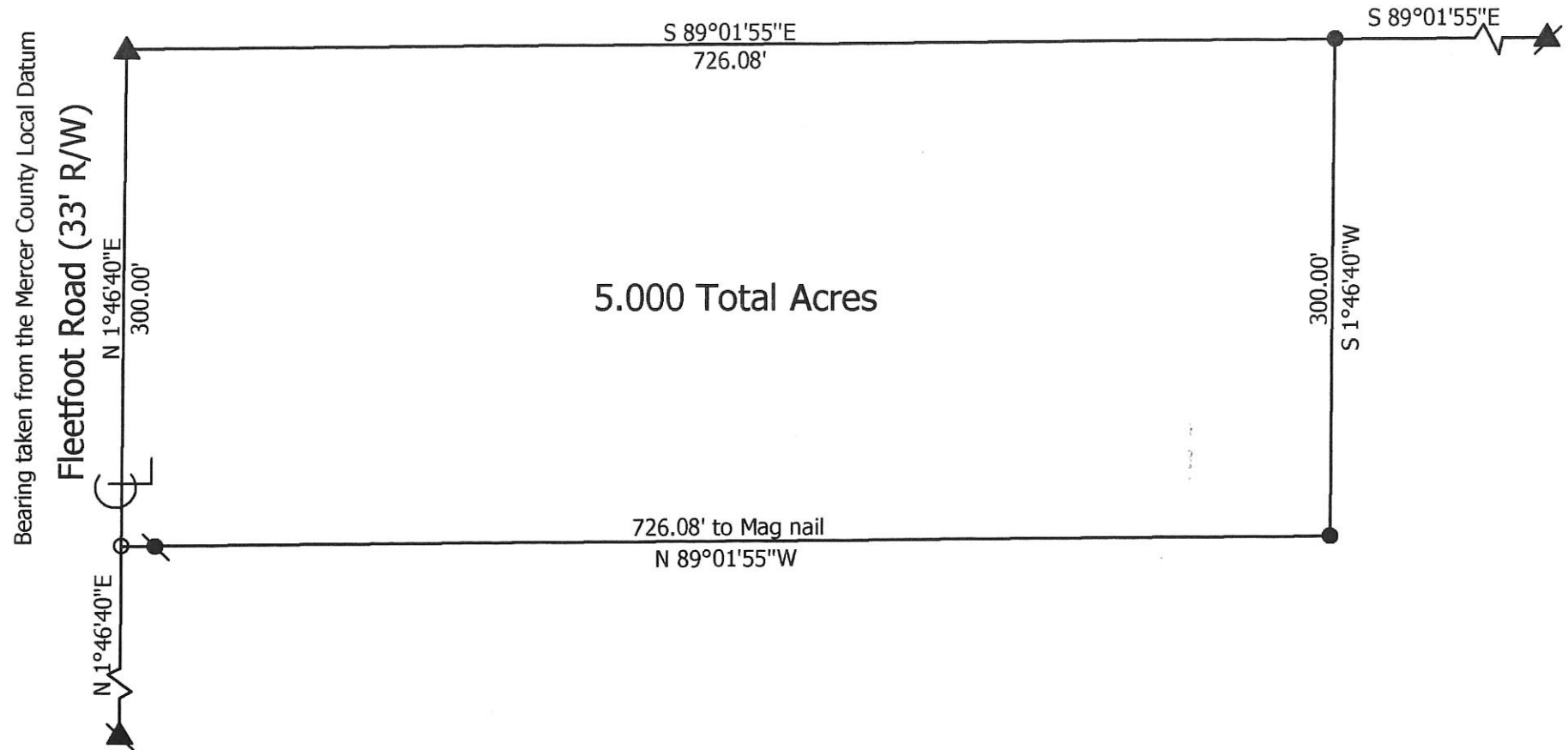
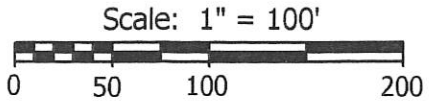
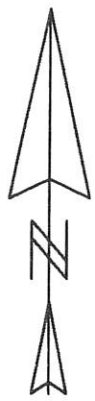
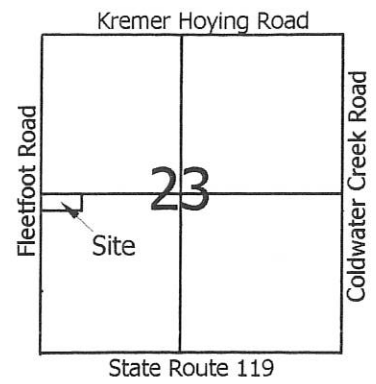

**Marbaugh
Land Surveying**

1210 Yorkshire Court
Celina, Ohio 45822
(419) 586-4293

Kent B. Marbaugh P.S. 7421



Uhlenhake Survey

State of: Ohio County: Mercer

Township: Granville Sec: 23 Town: 7S Range: 2E

City/Village: _____ Subdivision: _____ Lot: _____

Deed Ref: Vol. 313, Pg. 735 Date Surveyed: 6-15-06

Approvals: _____
Agency: Board of Health Township Zoning Inspector _____ County Engineer _____
Date: _____

11-F ✓

1123300002

11-F

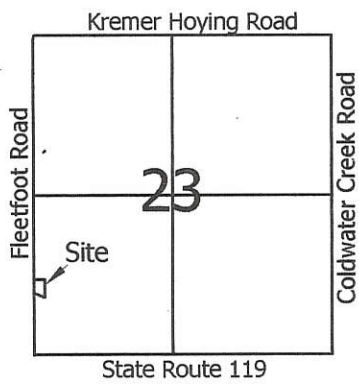

Legend:

- ▲ Cornerstone @ the W1/4 post of Section 23
- ▲ Cornerstone @ the SW corner of Section 23
- Mag nail set
- 5/8" X 30" Iron pin w/cap set
- ∅ Iron pipe found (Uhlenhake Subdivision)
- Uhlenhake Subdivision Line — — — — —

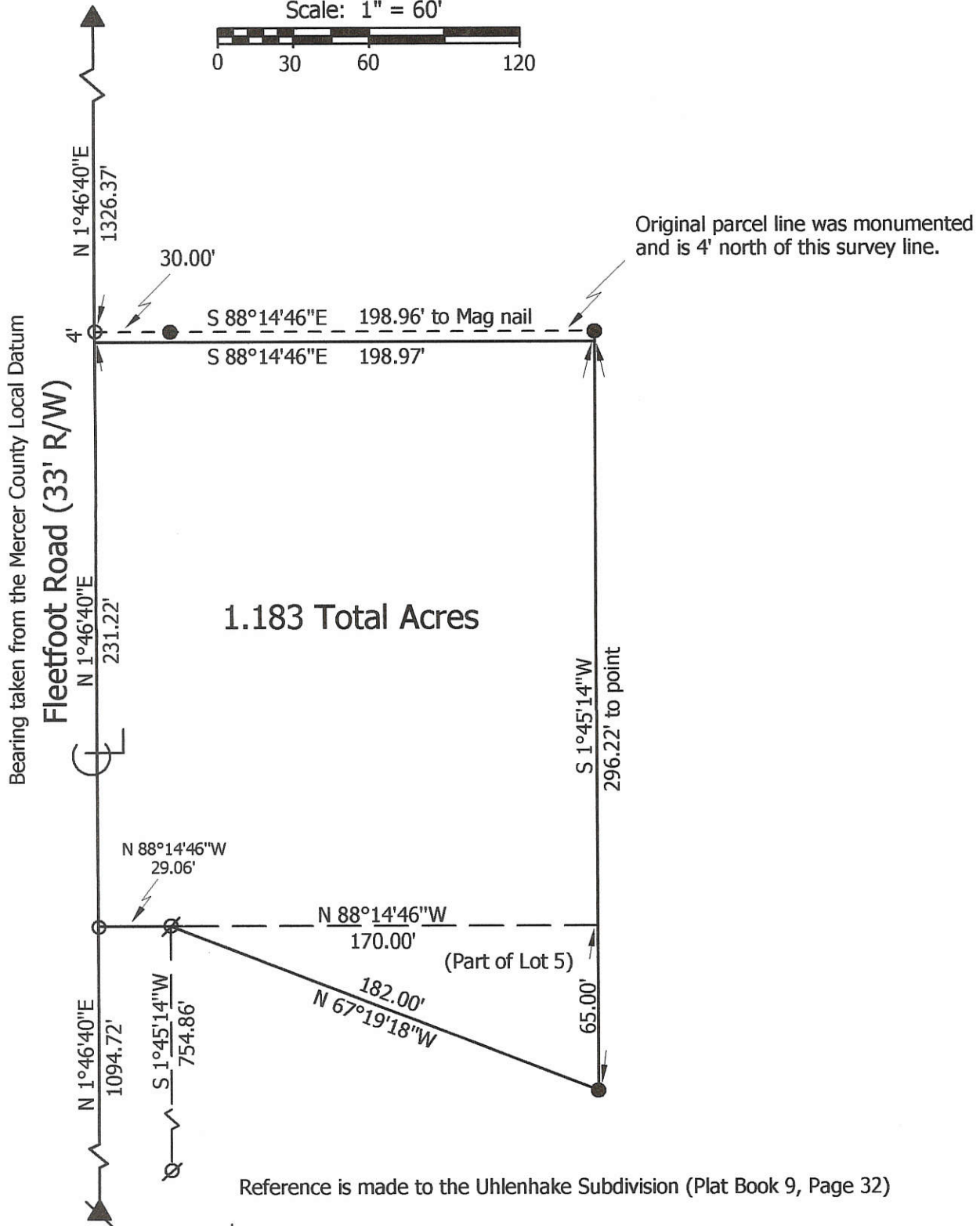
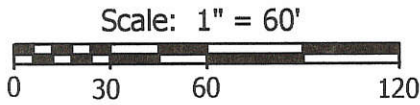

Marbaugh Land Surveying

1210 Yorkshire Court
 Celina, Ohio 45822
 (419) 586-4293

Kent Marbaugh
 Kent B. Marbaugh P.S.7421



Uhlenhake Survey

State of: Ohio County: Mercer

Township: Granville Sec: 23 Town: 7S Range: 2E

City/Village: _____ Subdivision: Uhlenhake Lot: pt. 5

Deed Ref: Vol. 272, Pg. 381 & Vol. 313, Pg. 735 Date Surveyed: 7-10-04

Approvals: _____	_____	_____
Agency: Board of Health	Township Zoning Inspector	County Engineer
Date: _____		

123300012

Legend:

- ▲ Cornerstone @ the W1/4 post of Section 23
- ▶ Cornerstone @ the SW corner of Section 23
- Mag nail set
- 5/8" X 30" Iron pin w/cap set
- ⊙ 5/8" X 30" Iron pin w/cap set on line and 20.0' from corner

Note: Reference is made to a prior survey by myself dated 11-26-09

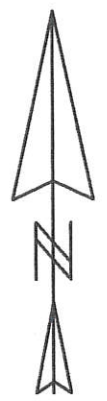
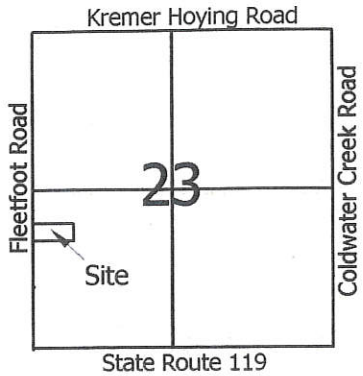

Approved by the Mercer
County Regional Planning
Commission; no plat
required under
R.C. 711.133

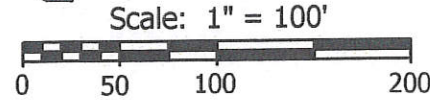

Todd & Vicki Topp
Inst.# 200900008053

S 89°01'55"E
726.08' to Mag nail

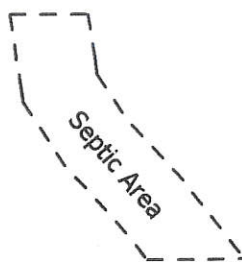

5.500 Total Acres

330.00'
S 1°46'40"W

726.08' to Mag nail
N 89°01'55"W

Carl Uhlenhake ETAL
Vol. 313, Page 735

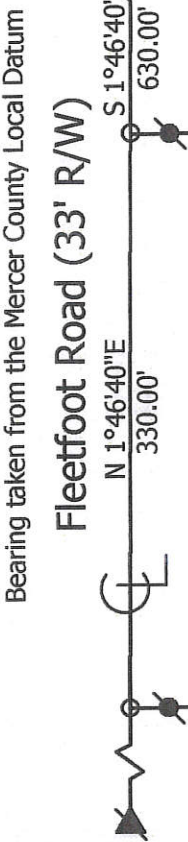

~~MINOR SUBDIVISION~~

Approved No Plat Required
For A Major Subdivision

Carl Uhlenhake
1 Lot

Uhlenhake Survey

State of: Ohio County: Mercer

Township: Granville Sec: 23 Town: 7S Range: 2E

City/Village: Subdivision: Lot:

Deed Ref: Vol. 313, Pg. 735 Date Surveyed: 1-21-12

Approvals: *CA* Board of Health
Agency: *Uhlenhake* Township Zoning Inspector
Date: 3-8-12
Mike Barrow County Engineer

Marbaugh Land Surveying

1901 Carolina Court
Celina, Ohio 45822
(419) 586-4293

Kent Marbaugh
Kent B. Marbaugh P.S. 7421

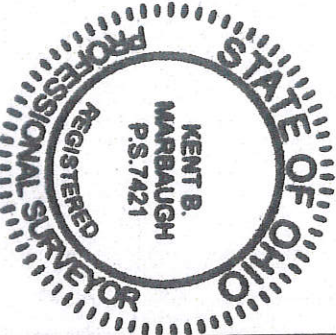

#2 11-F(2)

1123300014

LEGEND

- = MAG NAIL FOUND OVER CORNERSTONE .
- = 5/8 INCH IRON BAR FOUND.
- ⊗ = MAG NAIL SET .
- ⊙ = 5/8 INCH IRON BAR SET.



*** REFER TO SURVEYS BY K. MARBAUGH, P.S. 7421, DATED 7-10-04 AND 1-21-12.

5.50 ACRE PARCEL

W. 1/4 POST - SEC. 23

30.00'

960.00'

W. LINE - S.W. 1/4 - SEC. 23 & G FLEETFOOT RD. (33' R/W)

N 01°46'40" E 2656.42' BEARING BASED ON MER. CO. LOCAL GPS DATUM

231.22'

PAID

JUN 27 2016
\$200.00

MERCER COUNTY COMMISSIONERS
CELINA, OHIO
S.W. COR. - SEC. 23

N 89°01'55" W 270.93' (T)

2.129 TOTAL ACRES

0.129 AC. IN R/W

2.000 ACRES NET

16 1/2' R/W LINE

340.48'

S 88°14'46" E 254.40'

S 88°14'46" E 270.90' (T)

BRADLEY & CARMEN
BEYKE
1.183 ACRES
O.R. 189 PG. 423

** REFER TO SOIL EVALUATION REPORT BY BAKER SOIL SERVICES, 5-9-16, ON FILE IN THE MERCER CO. HEALTH DEPT.

JEROME & JANICE UHLENHAKE
58.352 AC. BY TAX MAP
INST. # 2012-6362

LOCATION SKETCH

EASEMENT AREA
0.175 ACRE

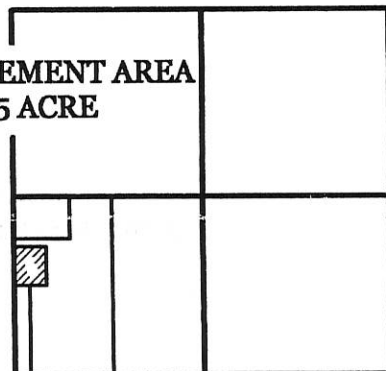

SECTION 23

UHLENHAKE SURVEY

PART OF THE W. 1/2 - S.W. 1/4 - SEC. 23, TOWN 7 SOUTH, RANGE 2 EAST, (GRANVILLE TOWNSHIP), MERCER COUNTY, OHIO .

JUNE 14, 2016

SCALE 1" = 100'



PAID

JUN 27 2016

Mercer Co. Health Dept.

SURVEYED BY

James W. Geeslin
JAMES W. GEESLIN
P.S. No. 7764

**GEESLIN
LAND SURVEYING**

525 S. SECOND ST.
COLDWATER, OHIO 45828
PHONE: (419) 678-7232



PERMANENT PARCEL No.	_____		
Part of	Sec. _____	T. _____	R. _____ Township
Grantor	Area Retained	Acres	
Grantee	Area Retained	Acres	
Deed References	_____		
APPROVALS AGENCY:	<i>[Signature]</i>	<i>[Signature]</i>	<i>[Signature]</i>
Board of Health	Date	Township Zoning Officer	County Engineer

6-27-16

6-27-16

11-F (23)

SURVEY OF A 1.552 AC. TRACT FOR J. LEISTENSCHNEIDER
LOCATED IN THE S.E. 1/4 OF SEC. 23, T-7-S, R-2-E,
GRANVILLE TWP., MERCER COUNTY, STATE OF OHIO

1123400003

AREA SURVEYED
1.552 Ac. Total
0.199 Ac. EX. R/W
1.353 Ac. Net

JAMES W.
LEISTENSCHNEIDER
Vol. 330, Pg. 883
Vol. 331, Pg. 401
Vol. 317, Pg. 279

DRIVE EASEMENT FOR
AGRICULTURAL USE
AREA OF EASEMENT
IS 0.179 ACRES

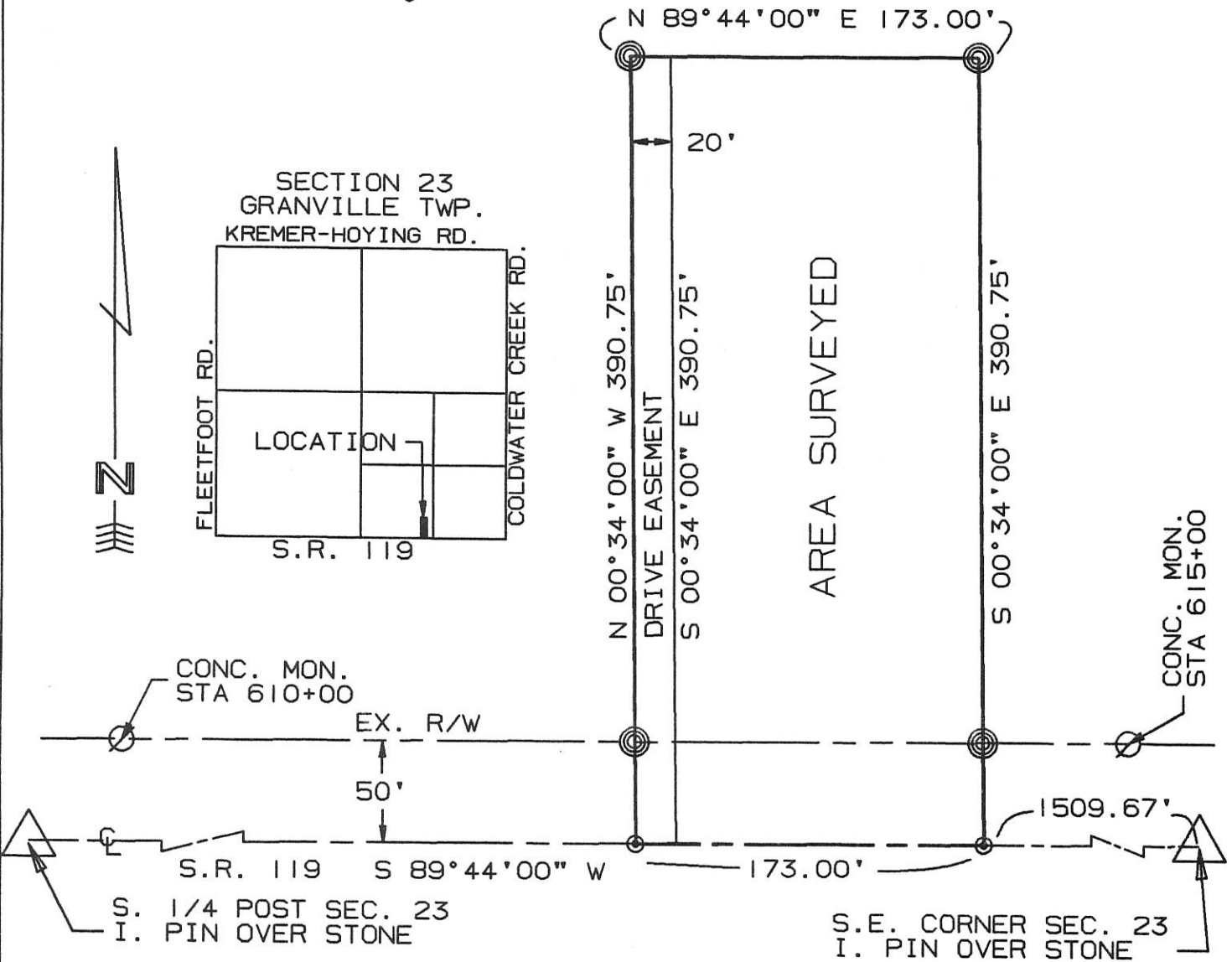

SURVEYED BY: Eric C. Thomas
ERIC C THOMAS REG. SURVEYOR #7236
DATE: 01-27-98

- ⊘ = I. PIN FND.
- ⊙ = I. PIN SET
- ⊗ = P.K. NAIL SET



References: R/W PLANS FOR S.R. 119		Scale 1"=80'	
Part of S.E. 1/4 Sec. 23 T7-S R2-E Granville Twp., MERCER Co., OHIO		0 40 80 160	
GRANTOR: <u>W. REIER</u> DEEDS: V-330, P-883 AREA RETAINED 4.120 Ac.			
GRANTEE: _____ AREA: <u>1.552</u> Ac.			
APPROVALS:	BD. OF HEALTH	Co. San. Eng.	Co. Engineer
AGENCY:			PERMANENT PARCEL No.
DATE			

SURVEY FOR MARVIN AND JEAN HOMAN

Part of the Southwest Quarter of Section 23, Town 7 South,
Range 2 East, Granville Township, Mercer County, Ohio.

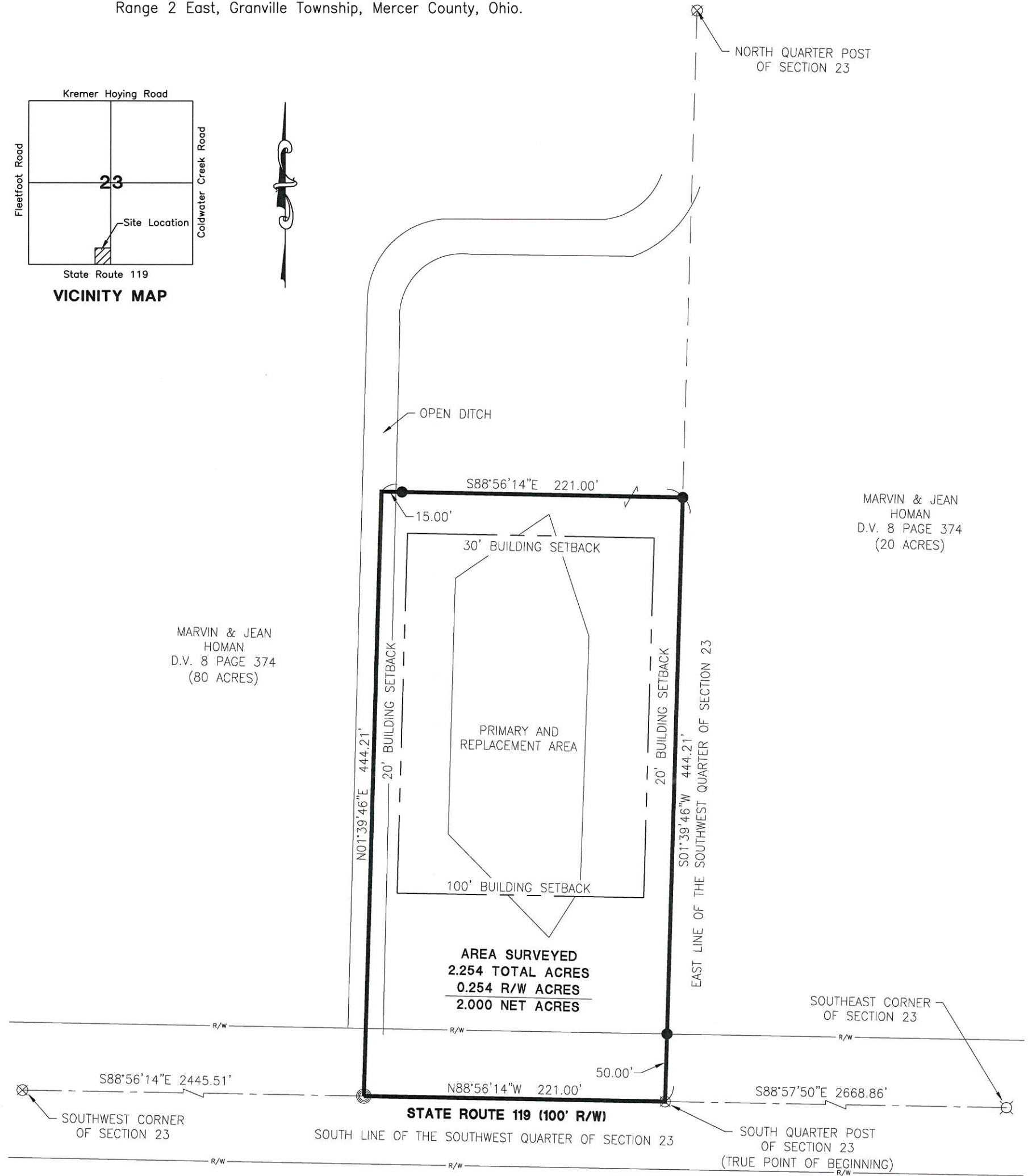
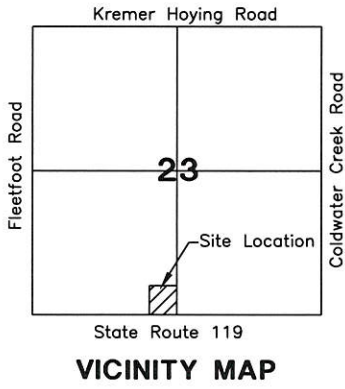

Craig Moeller 3-5-2019
County Engineer

D. M. W. R. S. 3-7-19
Health Department

Thomas Schmitz
Zoning Inspector

LEGEND

- ⊗ RR Spike Found
- Iron Pin Found
- Iron Pin Set
- ⊙ Mag Nail Set
- ⊗ Mag Nail Found
- Con Mon. Found
- △ Section Corner

Scale: 1" = 80'

PROJECT # 219808.07

ACCESS
Engineering Solutions
1200 IRMSCHER BLVD., SUITE B, CELINA, OH 45822
www.accessengllc.com | 419-586-1430



Basis of Bearings:
Mercer County Local Coordinate Datum.

State of: Ohio County: Mercer
Township: Granville
Sec.: 23 Town: 7S Range: 2E
Deed Ref.: D.V. 8 Page 374
Date Surveyed: February 8, 2019