

0720100002; 0720100003

ST. ANTHONY REAL ESTATE SURVEY

PART OF THE N.W. 1/4 OF SECTION 20, TOWN 6 SOUTH, RANGE 1 EAST, (WASHINGTON TOWNSHIP), MERCER COUNTY, OHIO.

JUNE 6, 2006

SCALE 1" = 50'



LEGEND

- △ = CORNERSTONE (REFER TO MERCER COUNTY STONE RECORDS).
- ⊗ = RAILROAD SPIKE FOUND . FOUND.
- ⊕ = IRON BAR FOUND.
- = 5/8 INCH IRON BAR FOUND.
- ⊗ = MAG NAIL SET.
- ⊙ = 5/8 INCH IRON BAR SET.

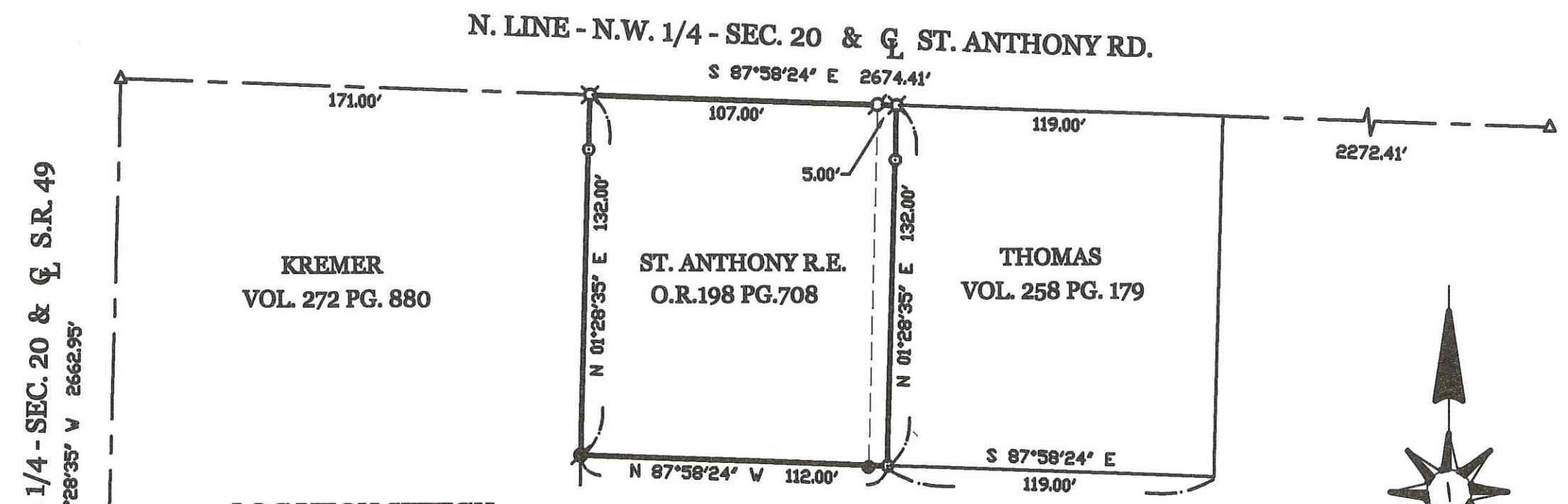

W. LINE - N.W. 1/4 - SEC. 20 & S.R. 49
S 01°28'35" V 2662.95'

LOCATION SKETCH

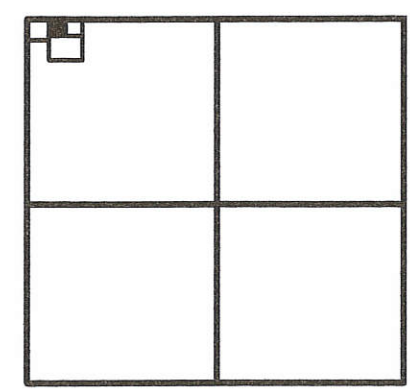

SECTION 20

SURVEY REFERENCES:

- 1) THOMAS SURVEY BY G. GEESLIN, P.S. 5372, DATED AUG. 1979.
- 2) SURVEY BY J. BROEKER, P.S. 5233.

SURVEYED BY

James W. Geeslin

JAMES W. GEESLIN
P.S. No. 7764

PERMANENT
PARCEL No. _____

Part of: _____ Sec. _____ T. _____ R. _____

Grantor: _____ Area Retained: _____ Acres

Grantee: _____ Area Transferred: _____ Acres

Deed References: _____

APPROVALS:
AGENCY: _____
DATE: _____

Board of Health

Township Zoning Officer

County Engineer



GEESLIN
LAND SURVEYING

P.O. BOX 422
CELINA, OHIO

PHONE (419) 586-6155
FAX (419) 678-9332

07-D ✓

07-D

0720100003

LEGEND

- "A" = STONE @ N. E. COR. ~ N.W. 1/4 ~ SEC. 20.
- "B" = STONE @ N. W. COR. ~ SEC. 20.
- "C" = STONE @ S.W. COR. ~ N.W. 1/4 ~ SEC. 20.
- "D" = RAILROAD SPIKE SET.
- "E" = 5/8 INCH IRON BAR SET.

N. LINE ~ N.W. 1/4 ~ SEC. 20 & ST. ANTHONY RD.

W. LINE ~ N.W. 1/4 ~ SEC. 20 & STATE ROUTE 49

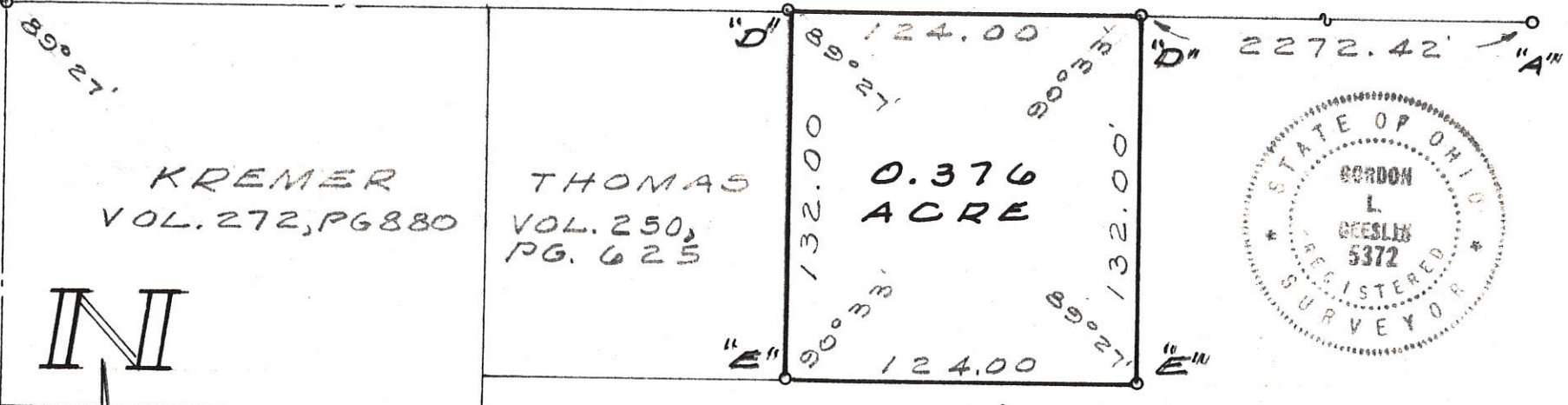

SURVEYED BY Gordon L. Geeslin
 GORDON L. GEESLIN
 REGISTERED SURVEYOR
 No 5372

THOMAS SURVEY ~ PT. N.W. 1/4 ~
 SECTION 20, TOWN 6 SOUTH, RANGE
 1 EAST (WASHINGTON TWP.),
 MERCER COUNTY, OHIO.
 AUGUST, 1979 SCALE 1" = 60'

0720100013

LOCATION SKETCH

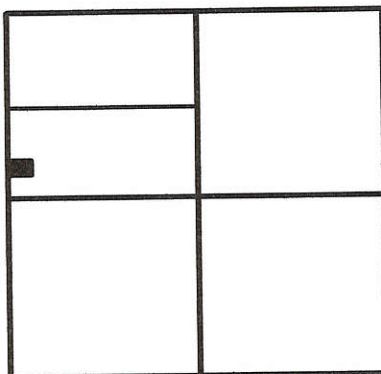

SECTION 20

N.W. COR.-
SEC. 20

W. LINE - N.W. 1/4 - SEC. 20 & Q STATE ROUTE 49

N 01°28'36" E 2663.12'

150.00'

30' R/W LINE

S 86°43'19" E 332.02'

302.00'

1.103 TOTAL ACRES
(0.103 AC. IN R/W)

S 01°28'36" W
139.56'

301.85'

N 88°31'24" W 331.85'

255.45'

S.W. COR.-
N.W. 1/4-
SEC. 20

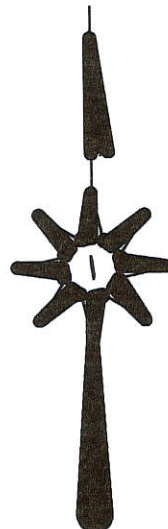

NOTE: A NEW SEPTIC SYSTEM WILL BE INSTALLED. THE SYSTEM WILL OUTLET INTO AN EXISTING FIELD TILE. SAID TILE IS TO BE LOCATED AT THE TIME OF CONSTRUCTION. INSTALLATION WILL BE SUBSEQUENT TO THE MERCER COUNTY HEALTH DEPARTMENT'S APPROVAL.

LEGEND

- = MAG NAIL FOUND OVER COR. SRONE.
- = 5/8 INCH IRON BAR FOUND OVER COR. STONE.
- ⊙ = MAG NAIL SET.
- ⊙ = 5/8 INCH IRON BAR SET.

SURVEYED BY

James W. Geeslin

JAMES W. GEESLIN
P.S. No. 7764

ALIG SURVEY

PART OF THE S. 1/2 OF THE N.W. 1/4 OF SECTION 20, TOWN 6 SOUTH, RANGE 1 EAST, (WASHINGTON TOWNSHIP), MERCER COUNTY, OHIO.

MARCH 7, 2005

SCALE 1" = 100'



**GEESLIN
LAND SURVEYING**

P.O. BOX 422
CELINA, OHIO 45822
PHONE: (419) 586-6155
FAX: (419) 678-9332

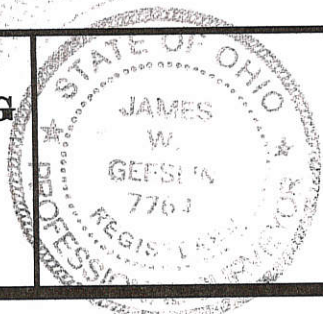

PERMANENT PARCEL No.	_____		
Part of	Sec. _____	T. _____	R. _____ Township
Grantor:	Area Retained	Acres	
Grantee:	Area Retained	Acres	
Deed References:	_____		
APPROVALS AGENCY:	<i>Chris Metz</i>	<i>James Geeslin</i>	<i>Deer Eichel</i>
	Board of Health Date	Township Zoning Officer Date	County Engineer Date
	3-17-05	3-15-05	3-16-05

07-0

SURVEY OF A 2.199 ACRE PARCEL FOR NORMAN ALIG
 LOCATED IN THE S. 1/2 OF THE N.W. 1/4 OF SEC. 20,
 T-6-S, R-1-E, WASHINGTON TWP., MERCER CO., OHIO

1 Lot
MINOR SUBDIVISION
Cal M
 Approved No Plat Required
 For A Major Subdivision

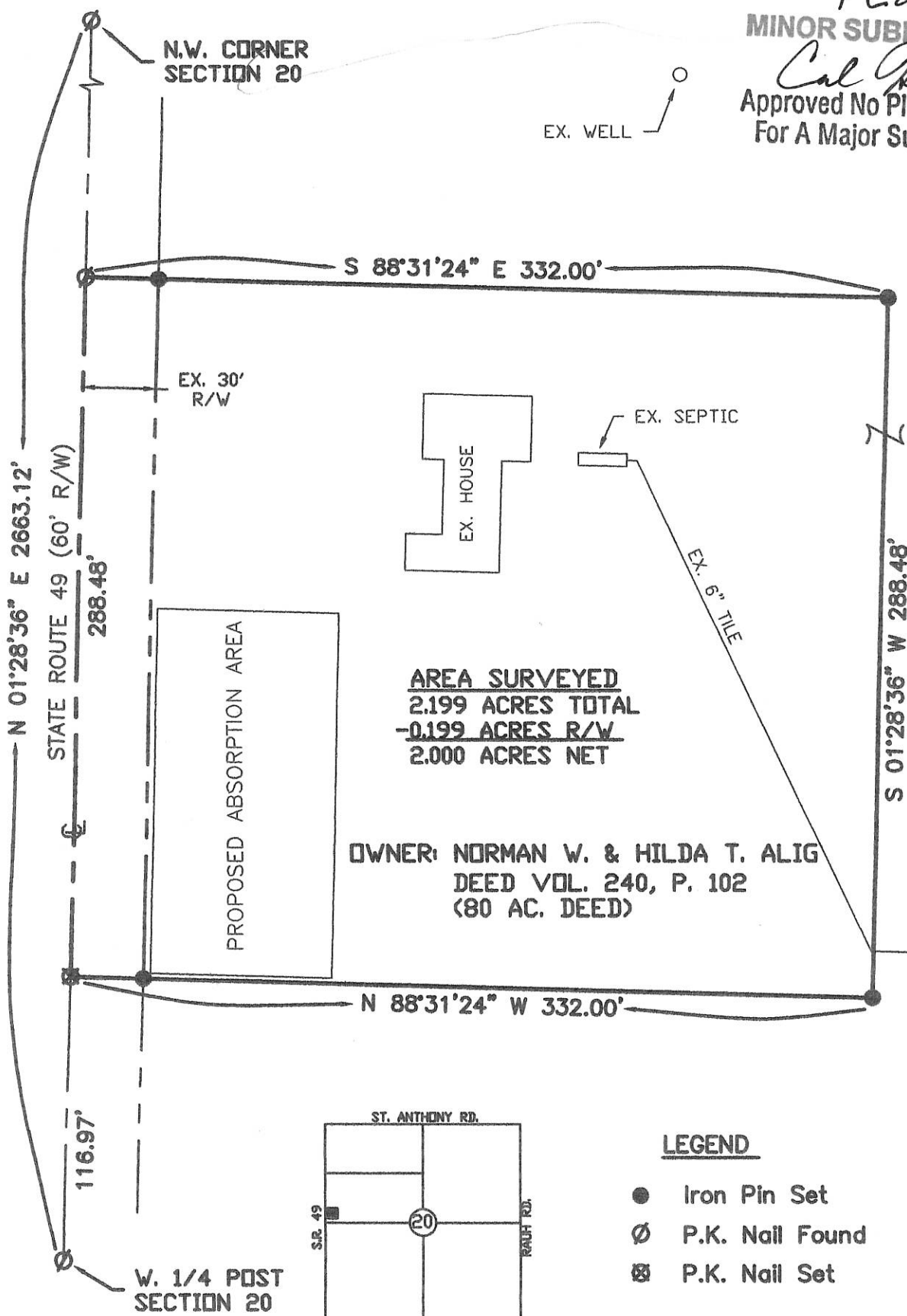

AREA SURVEYED
 2.199 ACRES TOTAL
~~0.199 ACRES R/W~~
 2.000 ACRES NET

OWNER: NORMAN W. & HILDA T. ALIG
 DEED VOL. 240, P. 102
 (80 AC. DEED)

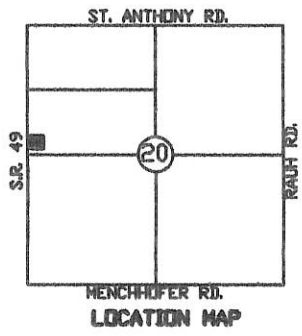

LEGEND

- Iron Pin Set
- ⊙ P.K. Nail Found
- ⊗ P.K. Nail Set



Surveyed By: *Eric C. Thomas*
 Eric C. Thomas Reg. Surveyor No. 7236
 Date: 5-5-09



References: PREVIOUS SURVEY OF THE AREA BY JAMES W. GESSLIN, REG. SUR. No. 7764	Scale: 1" = 60'
Part of <u>NW 1/4</u> Sec. <u>20</u> T <u>6-S</u> R <u>1-E</u> <u>WASHINGTON</u> Twp., Mercer Co., OH	
Grantor: _____ Deeds: _____ Area Retained: _____ Ac.	
Grantee: _____ Area: _____ Ac.	
Approvals: <i>Eric C. Thomas</i> Agency: Bd. of Health Date: 6-9-09	<i>James J. Jerny</i> Twp. Zoning Officer
<i>Norman Eickler</i> Co. Engineer 6-8-09	Permanent Parcel No. _____

0720100014

07-P(20)

0720 300003

Mark Homan
D.V. 333, Page 499

North line, S1/2, SW1/4

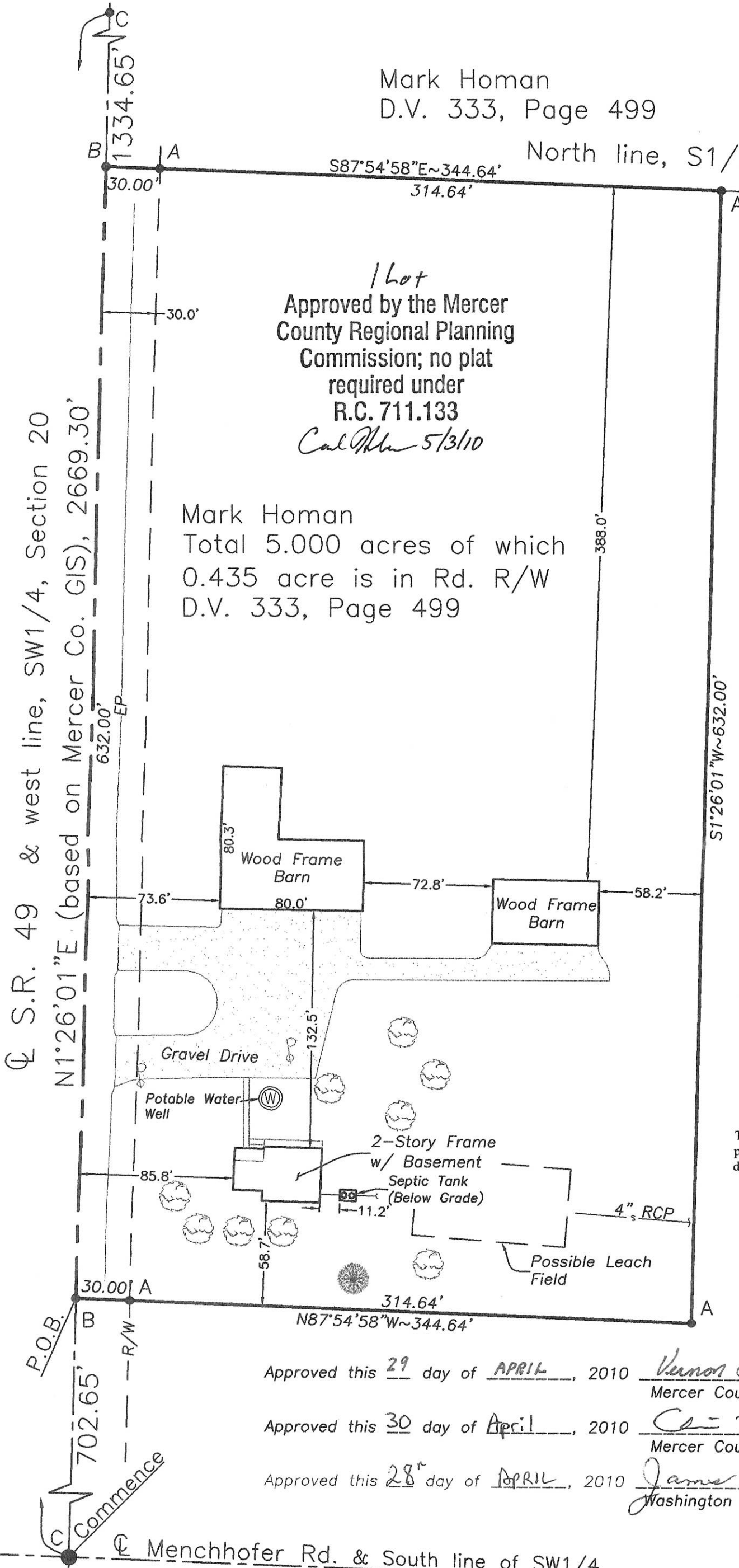

1 Lot
 Approved by the Mercer
 County Regional Planning
 Commission; no plat
 required under
 R.C. 711.133
Cal Mh 5/3/10

Mark Homan
 Total 5.000 acres of which
 0.435 acre is in Rd. R/W
 D.V. 333, Page 499

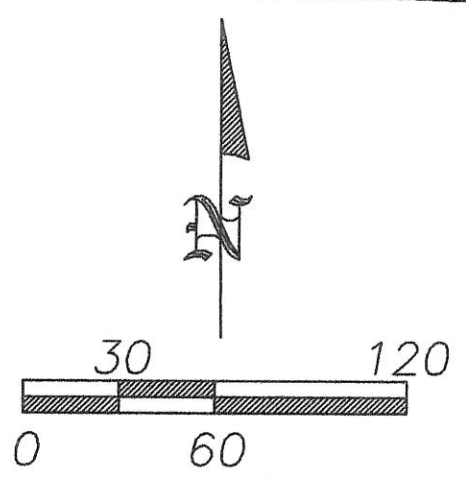

LEGEND

- A - Existing #5 rebar
- B - Existing Mag nail
- C - Existing #5 rebar at the SW corner of Section 20
- EP - Edge-of-pavement

Mark Homan
 D.V. 333, Page 499



Clayton T. Bacon
 Clayton T. Bacon, Reg. P.S. #6179

4-22-10

This description and plat is based on an actual field survey performed on 4-16-10, by Bacon & Associates under the direction of Clayton T. Bacon, P.S. #6179

Approved this 29 day of APRIL, 2010 *Vernor C. Eichler*
 Mercer County Engineer

Approved this 30 day of April, 2010 *Ca - m*
 Mercer County Health Department

Approved this 28th day of APRIL, 2010 *James Jennig*
 Washington Township Zoning Inspector

Menchofer Rd. & South line of SW1/4

Drainage Ditch

Revisions:	0
Drawn: BTB	4-22-10

Mr. Mark Homan
 S1/2, SW1/4, Section 20, T6S, R1E
 Washington Township, Mercer County, Ohio

Prepared By
Bacon & Associates, L.L.C.
 750 N. Eastown Rd., Elida, Ohio 45807
 Office: (419) 999-3756 - Fax: (419) 999-2523

07-D(20)

0720400001

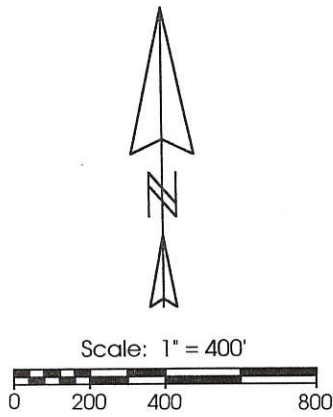
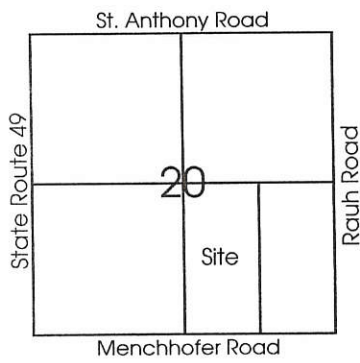

Legend:

- ▲ Cornerstone @ N1/4 Post of Section 20
- ▲ Cornerstone @ W1/4 Post of Section 20
- ▲ Cornerstone @ E1/4 Post of Section 20
- △ Cornerstone @ S1/4 Post of Section 20
- △ Cornerstone @ SE Corner of Section 20
- MAG Nail set
- 5/8" X 30" Iron Pin w/cap set

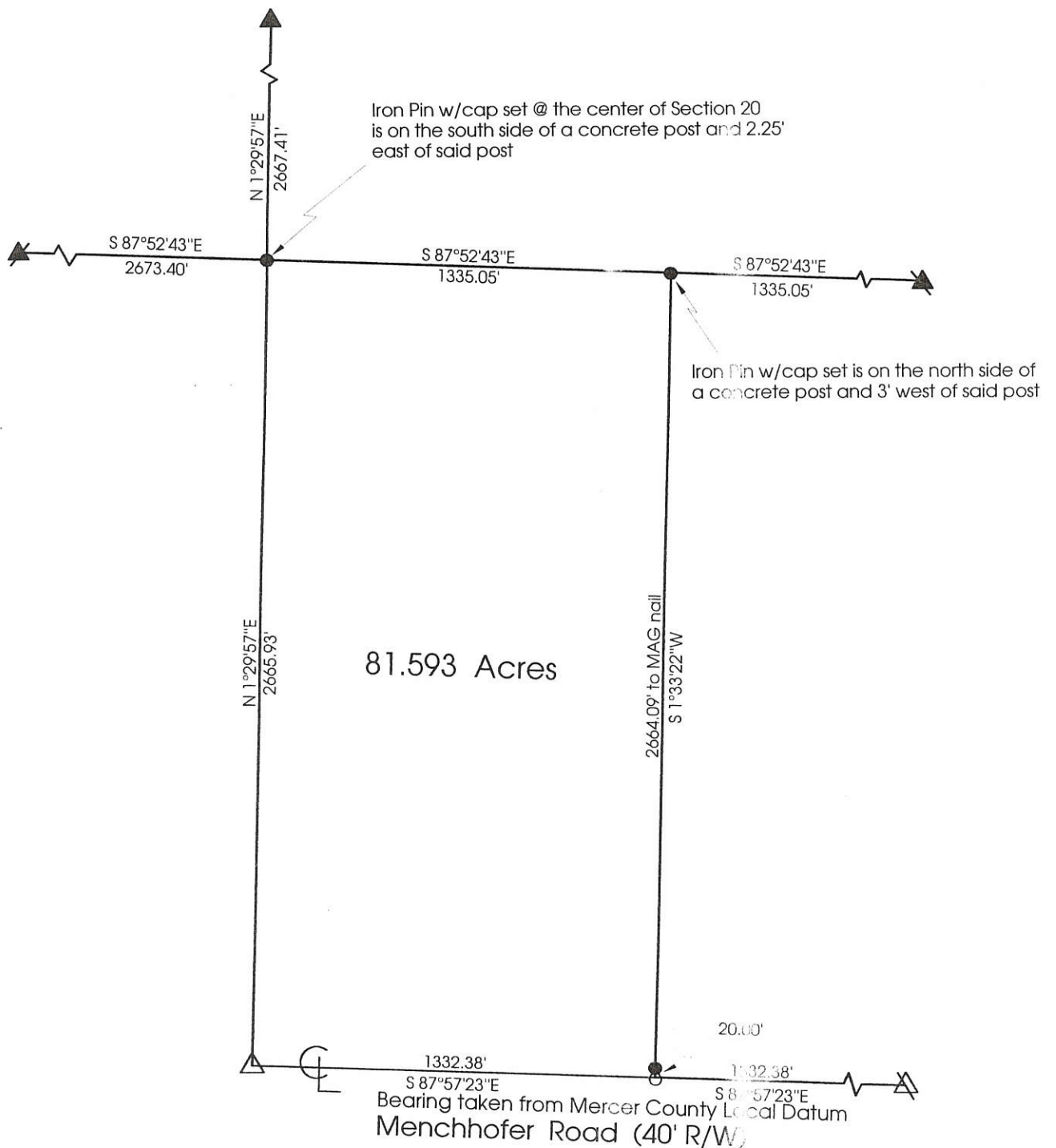

**Marbaugh
Land Surveying**
1210 Yorkshire Court
Celina, Ohio 45822
(419) 586-4293
Kent B. Marbaugh
Kent B. Marbaugh P.S. 7421



Baytion Survey

State of: Ohio County: Mercer
 Township: Washington Sec: 20 Town: 6S Range: 1E
 City/Village: _____ Subdivision: _____ Lot: _____
 Deed References: O.R. 70 Pg. 221 Date Surveyed: 1-19-00

Approvals: _____
 Agency: Board of Health County Sanitary Engineer _____ County Engineer _____
 Date: _____

0720400003

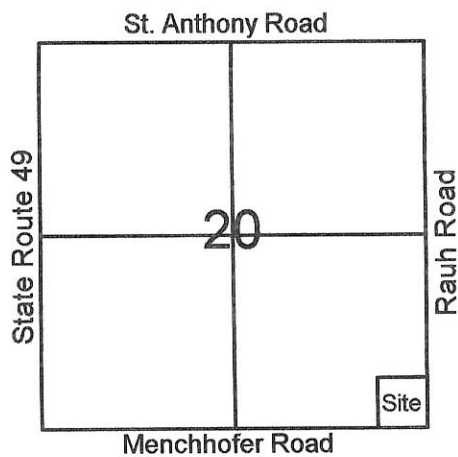

Legend:

- ▲ Cornerstone @ E1/4 Post of Section 20
- △ Cornerstone @ S1/4 Post of Section 20
- ⊗ Cornerstone @ SE Corner of Section 20
- MAG Nail set
- 5/8" X 30" Iron Pin w/cap set

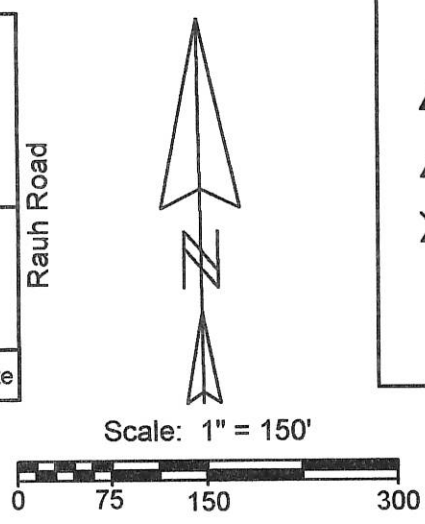

1 Lot
 Approved by the Mercer
 County Regional Planning
 Commission; no plat
 required under
 R.C. 711.133
Callahan 5/13/10

Kevin Dues
 Inst.# 200800000720

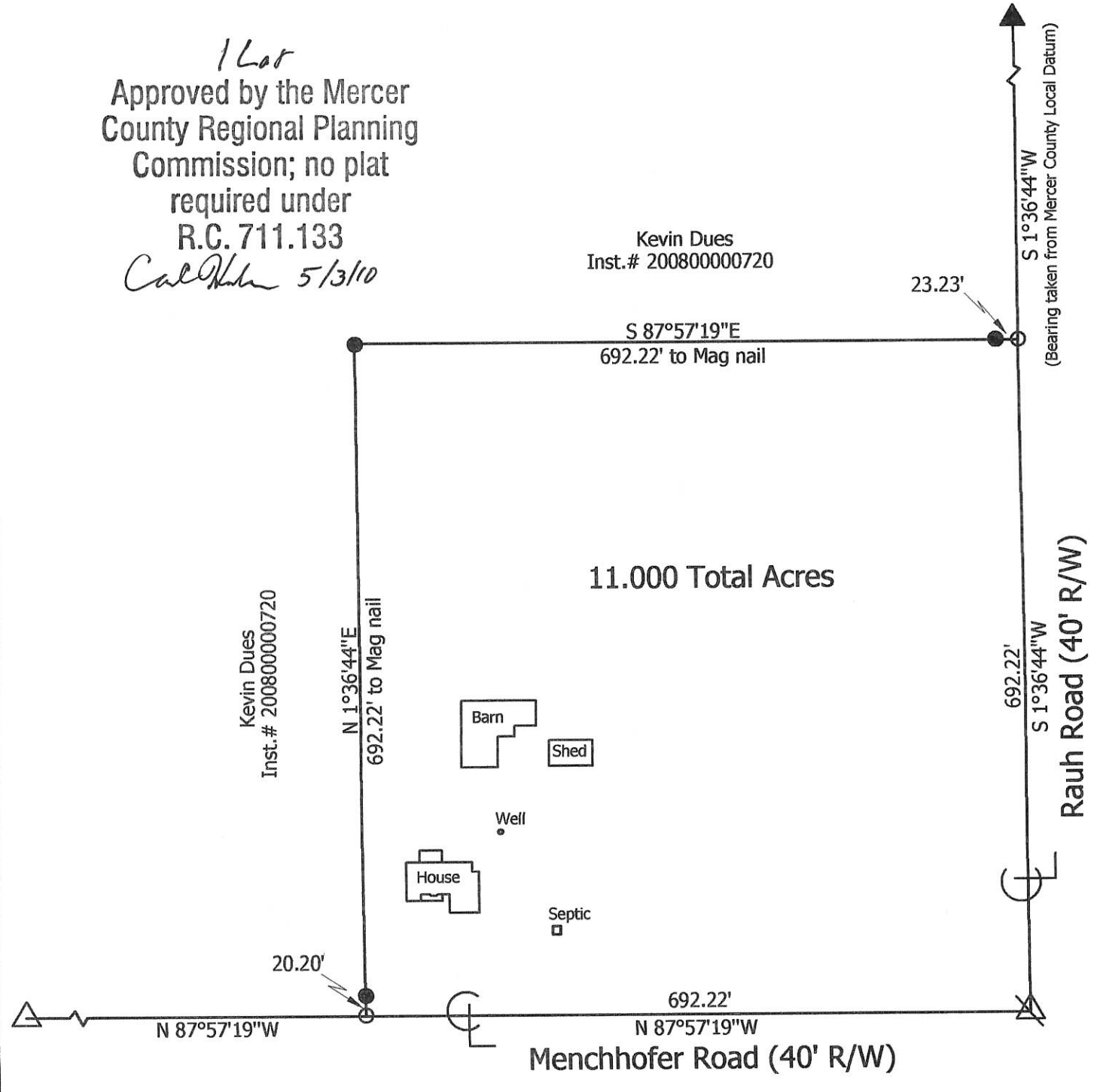

**Marbaugh
 Land Surveying**

1901 Carolina Court
 Celina, Ohio 45822
 (419) 586-4293

Kent Marbaugh
 Kent B. Marbaugh P.S. 7421



Dues Survey (949 Menchhofer Road)

State of: Ohio County: Mercer
 Township: Washington Sec: 20 Town: 6S Range: 1E
 City/Village: _____ Subdivision: _____ Lot: _____
 Deed Ref: Inst.# 200800000720 Date Surveyed: 2-18-10

Approvals: *James Fenwick* Township Zoning Inspector
Kevin Eickler County Engineer
 Date: 4-30-10

07-D(20)

N.W. COR. -
SEC. 20

LEGEND

- = MAG NAIL FOUND .
- = 5/8 INCH IRON BAR FOUND .
- = 5/8 INCH IRON BAR SET .
- ⊙ = MAG NAIL SET .
- × = CORNER NOT SET AT REQUEST OF CLIENT .

LOCATION SKETCH

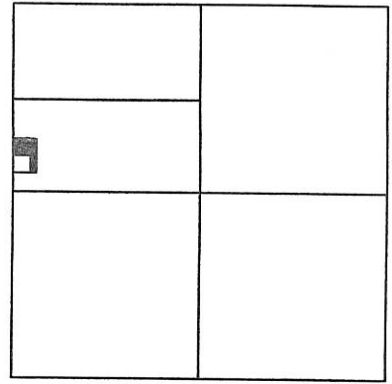

SECTION 20

*** REFER TO SOIL EVALUATION REPORT BY M. DEATON, 8/20/17. ON FILE IN THE MERCER COUNTY HEALTH DEPT..



SURVEY REFERENCES :
 1) PRIOR SURVEY FOR ALIG , 3-7-05.
 2) SURVEY FOR N. ALIG BY E. THOMAS , 5-5-09.

W. LINE - N.W. 1/4 - SEC. 20 & S.R. 49 (60' R/W)
 (BEARING BASED ON MER. CO. LOCAL GPS DATUM)
 N 01°28'36" E 2663.12' (30' R/W LINE)

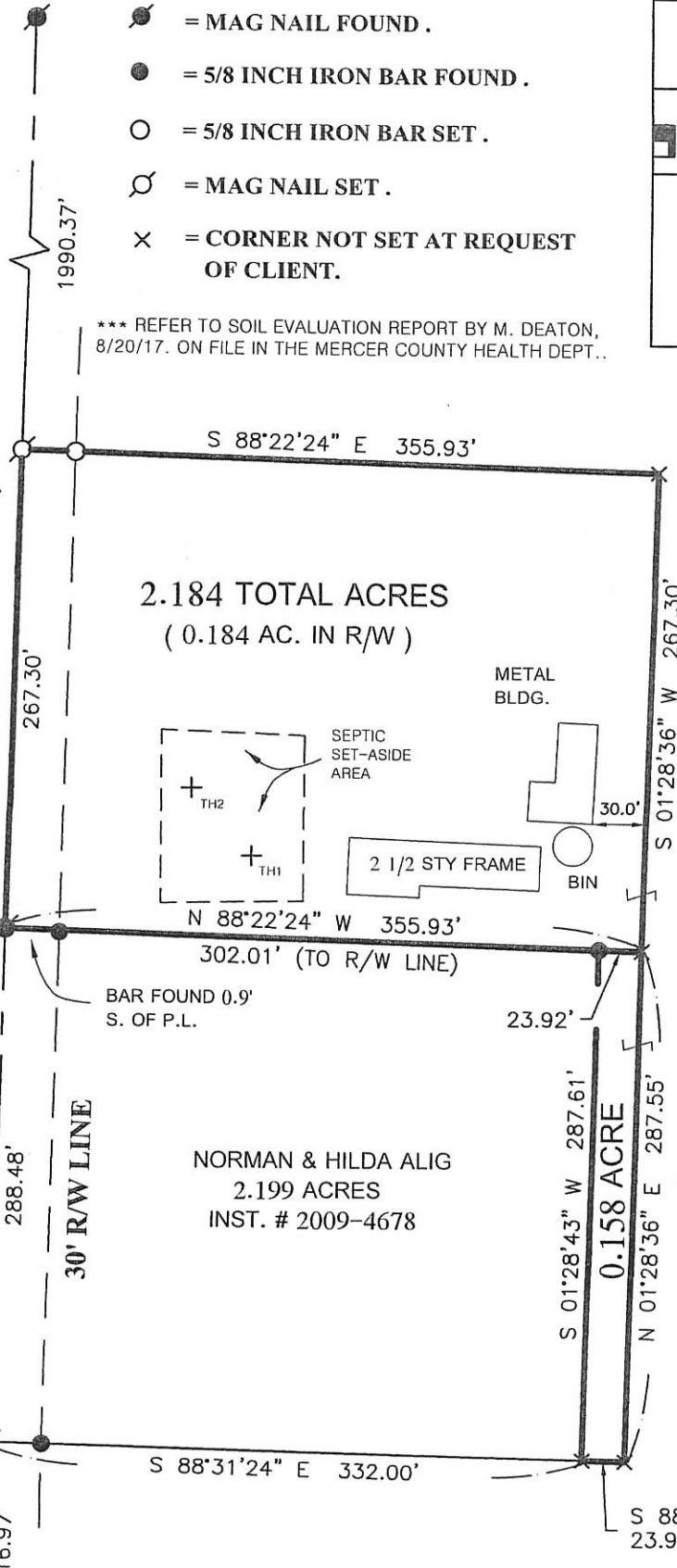

2.184 TOTAL ACRES
(0.184 AC. IN R/W)

METAL BLDG.

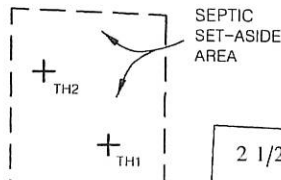

SEPTIC SET-ASIDE AREA

2 1/2 STY FRAME

BIN

BAR FOUND 0.9' S. OF P.L.

NORMAN & HILDA ALIG
2.199 ACRES
INST. # 2009-4678

MINOR SUBDIVISION
1600
Cynthia 10/5/17

RICK & SHARON ALIG
77.801 AC.
INST. # 2010-7115

SURVEYED BY

James W. Geeslin
 JAMES W. GEESLIN
 PROFESSIONAL SURVEYOR 7764

Approved No Plat Required
For A Major Subdivision

PAID

OCT 03 2017

Mercer Co. Health Dept.

PAID

OCT 03 2017
 1520-00-1107
 MERCER COUNTY COMMISSIONERS
 CELINA, OHIO
J. Nagel

ALIG SURVEY

W. 1/4 POST - SEC. 20 PART OF THE S. 1/2 - N.W. 1/4 - SEC. 20 , T. 6 S. , R. 1 E. , (WASHINGTON TOWNSHIP) , MERCER COUNTY , OHIO .

AUGUST 28, 2017

SCALE 1" = 100'

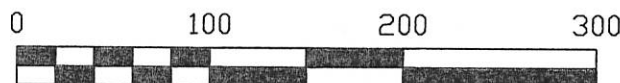

GEESLIN LAND SURVEYING

525 S. SECOND ST.
COLDWATER, OHIO 45828

PHONE: (419)678-7233
geeslinsurveying@gmail.com

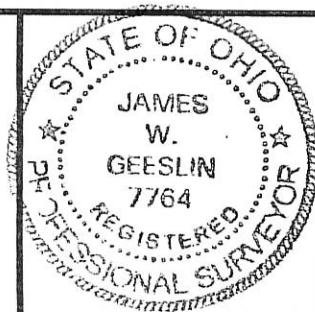

PERMANENT PARCEL No. _____

Part of: _____ Sec. _____ T. _____ R. _____ Township _____

Grantor: _____ Area Retained: _____ Acres

Grantee: _____ Area Retained: _____ Acres

Deed References: _____

APPROVALS: _____
 AGENCY: Board of Health
 DATE: 10-3-17

_____ Township Zoning Officer
 _____ County Engineer 9-29-17

07-D(20)