

SUDHOFF SURVEY
 PART FRACT. SEC. 6, T6S, R1E, WASHINGTON TWP.
 MERCER CO., OHIO

Co Engr. ~~#10A~~
 07-A(6)

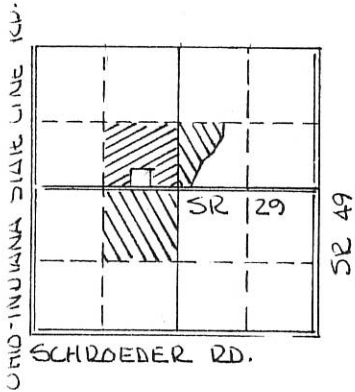

SCALE - 1" = 300'

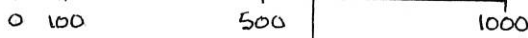

LEGEND:

- △ STONE REF.
- EXIST COR POSTS
- IRON PINS
- + POINT.

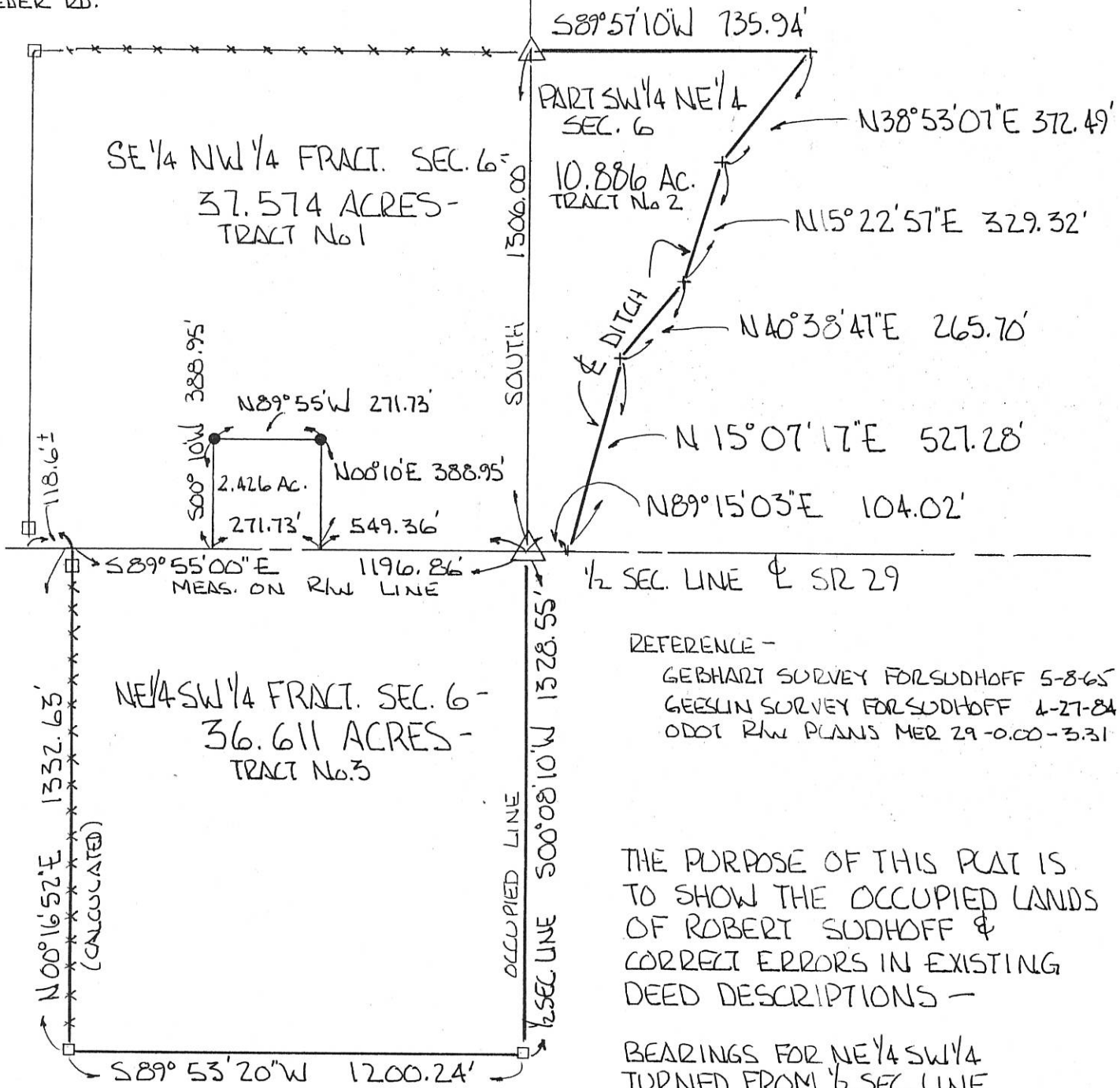

REFERENCE -
 GEBHART SURVEY FOR SUDHOFF 5-8-65
 GEESLIN SURVEY FOR SUDHOFF 4-27-84
 ODOT R/W PLANS MER 29-0.00-3.31

THE PURPOSE OF THIS PLAT IS
 TO SHOW THE OCCUPIED LANDS
 OF ROBERT SUDHOFF &
 CORRECT ERRORS IN EXISTING
 DEED DESCRIPTIONS -

BEARINGS FOR NE 1/4 SW 1/4
 TURNED FROM 1/2 SEC. LINE
 EST. S89°55'00"E BY GEBHART
 BEARINGS FOR PART SW 1/4 NE 1/4
 TURNED FROM 1/2 SEC. LINE
 ASSUMED NORTH-SOUTH

Roy F. Thompson, Jr.
 ROY F. THOMPSON, JR. REG. SUR# 5379



0706100003
 0706300004
 0706100002

0706100002

07-A 41
Robert Sudhoff Survey.
NW 1/4 Section 6, T6S-R1E
Washington Twp. Mercer Co. O.
5-8-65

Detail showing iron pipe in reference
to existing fence lines
at Points A-B-C-D

1/4 sec
white deed lines
for Robt. Sudhoff
add 1.46 acres
to Mark Strake

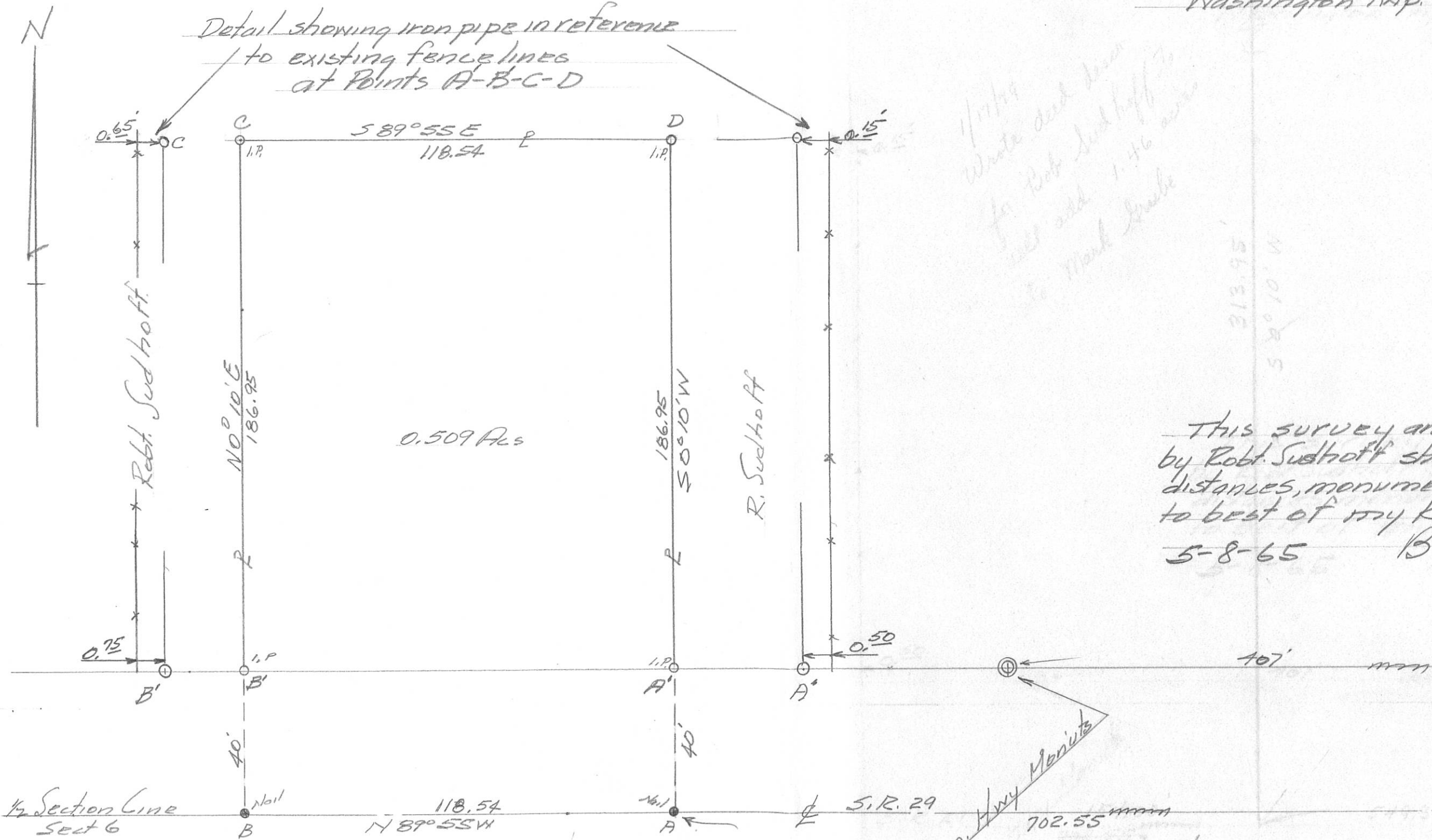

This survey and plat requested
by Robt. Sudhoff showing bearings
distances, monuments is correct
to best of my knowledge.
5-8-65 B. R. Hubbard

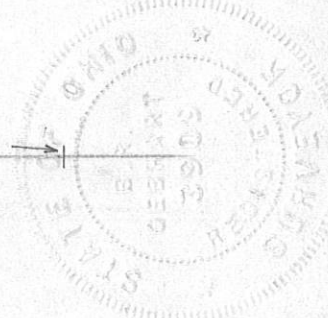

Bearings are magnetic
Line A-B observed, others computed
from angles turned in field.

SCALE 1" = 30'

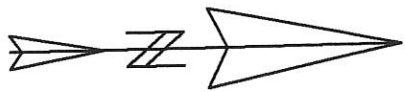
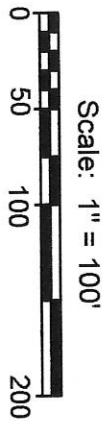
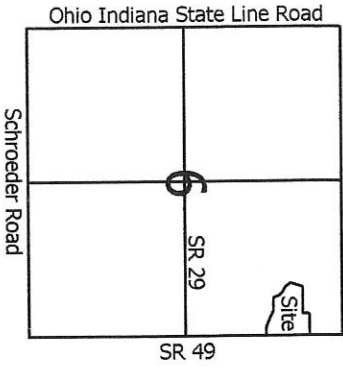

Legend:

- △ Mag nail @ the E1/4 Post of Section 6
- ▽ Mag nail @ the NE corner of Section 6
- 5/8" X 30" Iron pin w/cap set
- Mag nail set

Line	Bearing	Distance
1	N 64°58'52"W	71.76'
2	N 86°29'18"W	74.12'
3	N 77°49'20"W	75.61'
4	N 46°28'53"W	68.92'

Parent
 Parcel: 43-000300.0100
 Map: 07-06-200-003

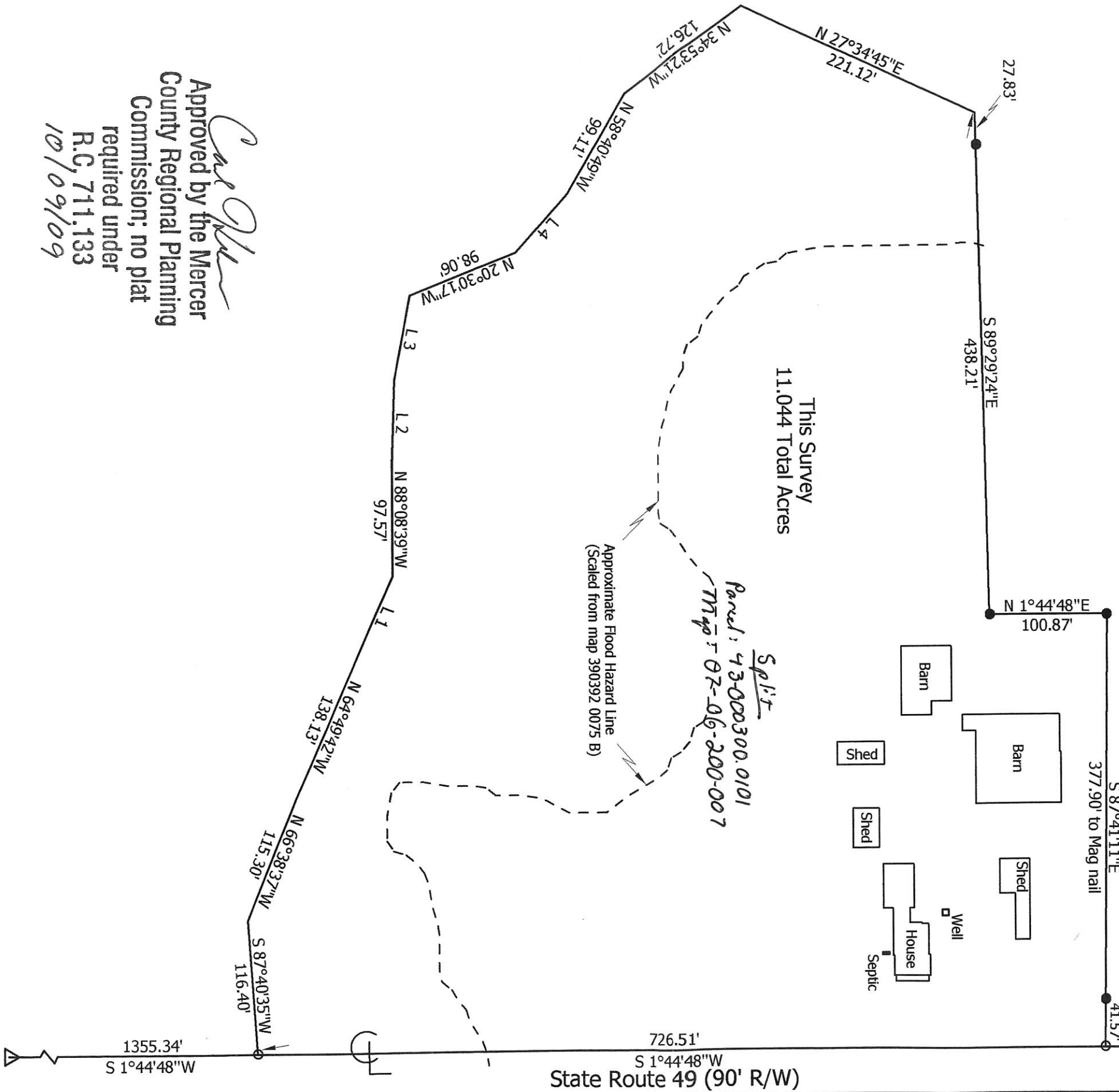

Carl Allen
 Approved by the Mercer
 County Regional Planning
 Commission; no plat
 required under
 R.C. 711.133
 10/09/09

Marbaugh
Land Surveying

1901 Carolina Court
 Celina, Ohio 45822
 (419) 586-4293

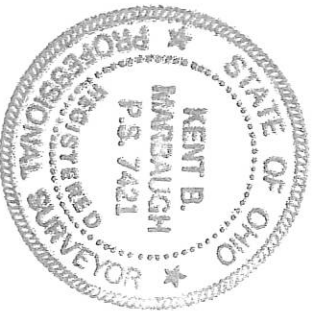

Muhlenkamp to Schmidt Survey

(6931 S.R. 49)

State of: Ohio County: Mercer

Township: Washington Sec: 6 Town: 6S Range: 1E

City/Village: _____ Subdivision: _____ Lot: _____

Deed References: O.R. 80, Page 851 Date Surveyed: 9-26-09

Approvals: _____
 Agency: Board of Health Township Zoning Inspector
 Date: 10-9-09 _____
Wanna Eickler
 County Engineer
10-8-09

Kent B. Marbaugh P.S. 7421

07A(6)

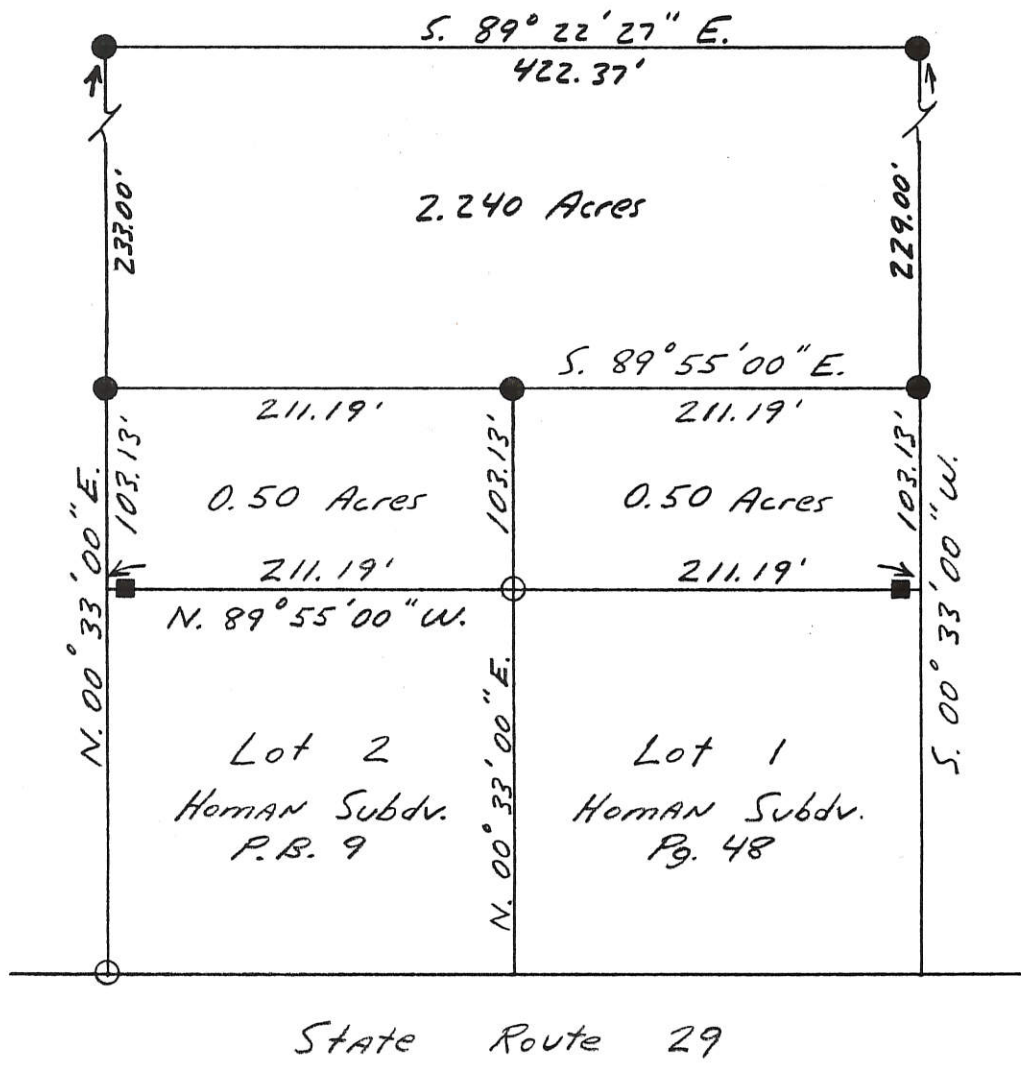
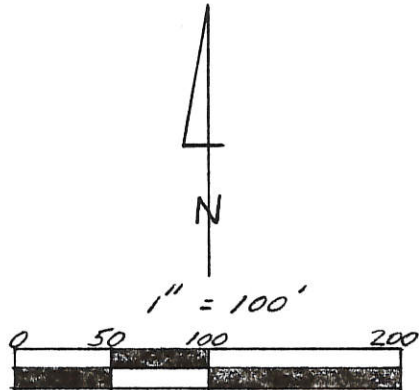
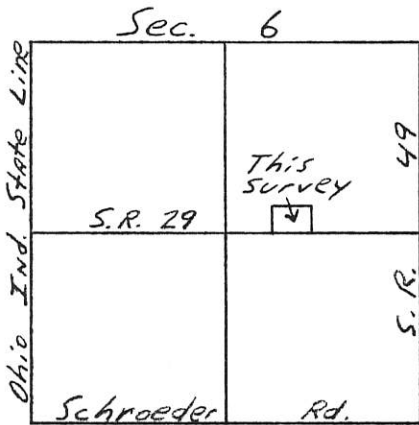

Legend

- Fd. Patented Survey Stake
- Fd. Conc. Mon. 5' from property line
- 5/8" x 30" Iron Pin w/cap Set

Kent B. Marbaugh

P.S. 7421

1210 Yorkshire Court
Celina, Ohio 45822
(419) 586-4293

7-27-01

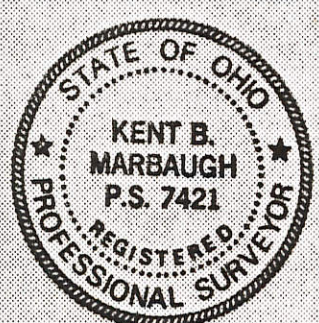

Kent Marbaugh

Homan Survey

Part of: NE 1/4 Sec. 6 T 65 R 1 E Wash. Township

Grantor: _____ Area Retained: _____ Ac.
Grantee: _____ Area Transferred: _____ Ac.

References: Plat Book 9 Page 48

Approvals: _____	_____	_____
Agency: Board of Health	County Sanitary Engineer	County Engineer
Date: _____		

070620004;
070620005

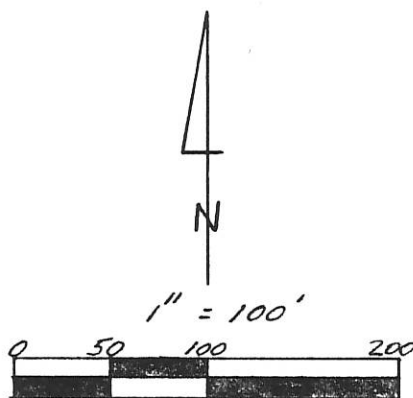
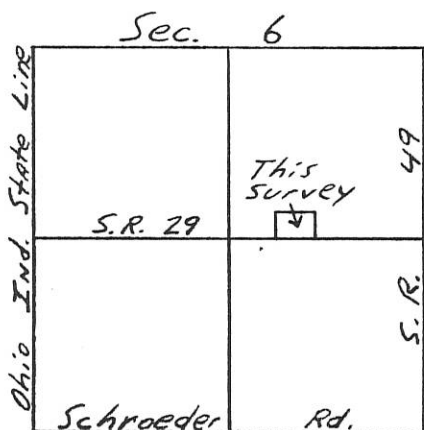

Legend

- Fd. Patented Survey Stake
- Fd. Concl. Mon. 5' from property line
- 5/8" x 30" Iron P.N w/cap Set

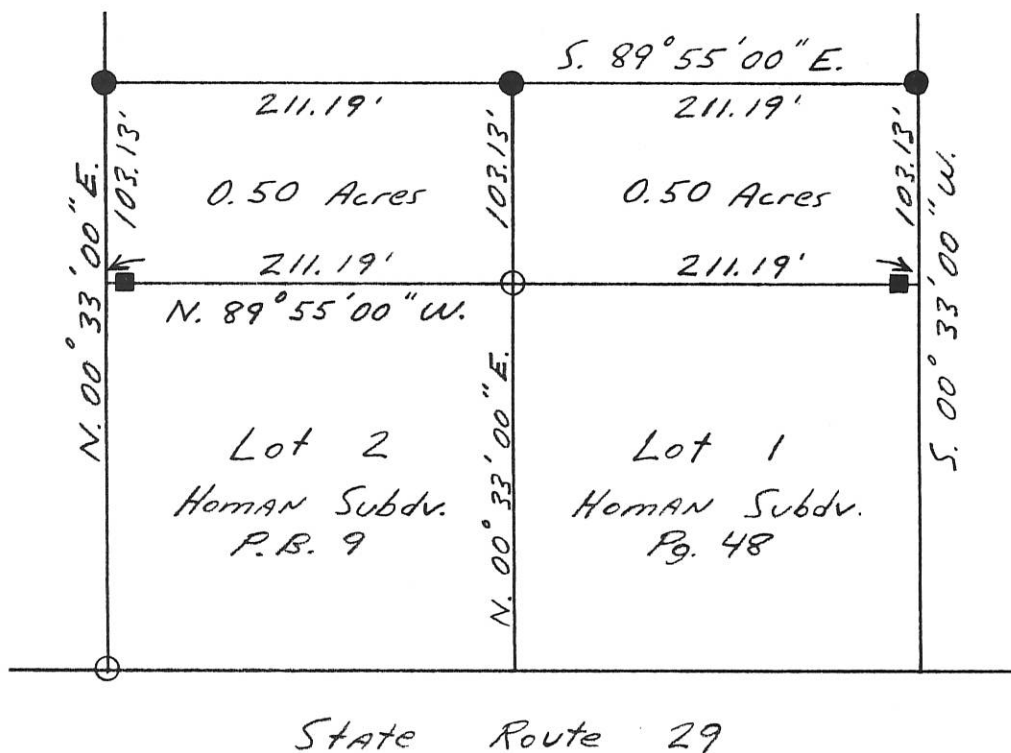

Kent B. Marbaugh

P.S. 7421

1210 Yorkshire Court
Celina, Ohio 45822
(419) 586-4293

4-19-95



Kent Marbaugh

Homan Survey

Part of: NE 1/4 Sec. 6 T 65 R 1 E Wash. Township

Grantor: _____ Area Retained: _____ Ac.

Grantee: _____ Area Transferred: _____ Ac.

References: Plat Book 9 Page 48

Approvals: _____
Agency: Board of Health County Sanitary Engineer County Engineer
Date: _____

II II

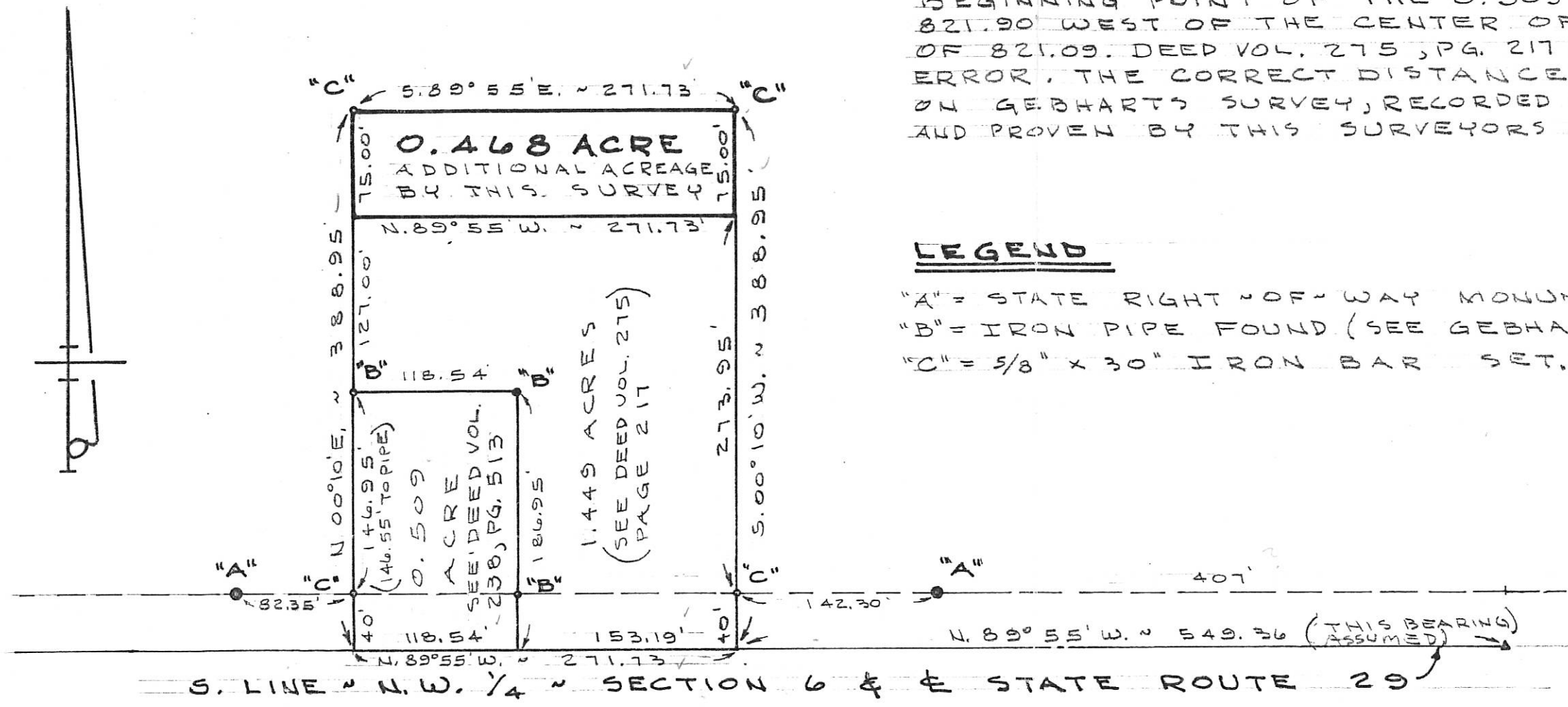

NOTE

DEED VOLUME 238, PG. 513 ERRONEOUSLY CALLS THE BEGINNING POINT OF THE 0.509 ACRE TRACT TO BE 821.90 WEST OF THE CENTER OF SECTION 6 IN LIEU OF 821.09. DEED VOL. 275, PG. 217 CONTINUES WITH THIS ERROR. THE CORRECT DISTANCE OF 821.09 IS SHOWN ON GEBHART'S SURVEY, RECORDED IN SURVEY BOOK 7, PG 153, AND PROVEN BY THIS SURVEYORS FIELD INVESTIGATION.

LEGEND

- "A" = STATE RIGHT-OF-WAY MONUMENT
- "B" = IRON PIPE FOUND (SEE GEBHART SURVEY.)
- "C" = 5/8" x 30" IRON BAR SET.

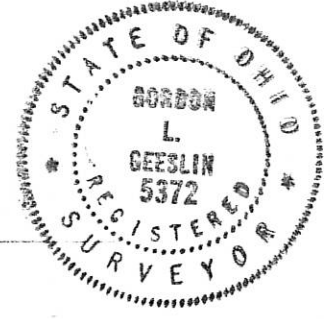

LOCATION SKETCH

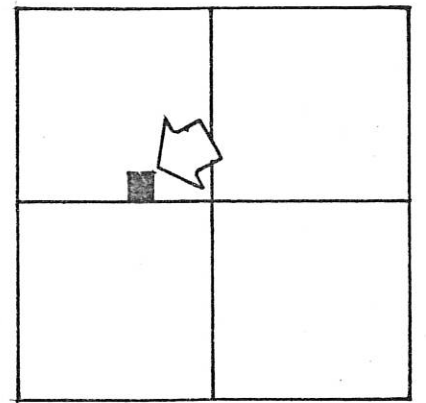

SECTION 6

070620005
070620004

SURVEYED BY Gordon L. Geeslin
 GORDON L. GEESLIN
 REGISTERED SURVEYOR
 No. 5372
 CELINA, OHIO

SUDHOFF SURVEY ~ PART OF THE
 N. W. 1/4 OF SECTION 6, TOWN 6 SOUTH,
 RANGE 1 EAST, (WASHINGTON TWP.),
 MERCER COUNTY, OHIO.
 APRIL 27, 1984 SCALE 1" = 100'

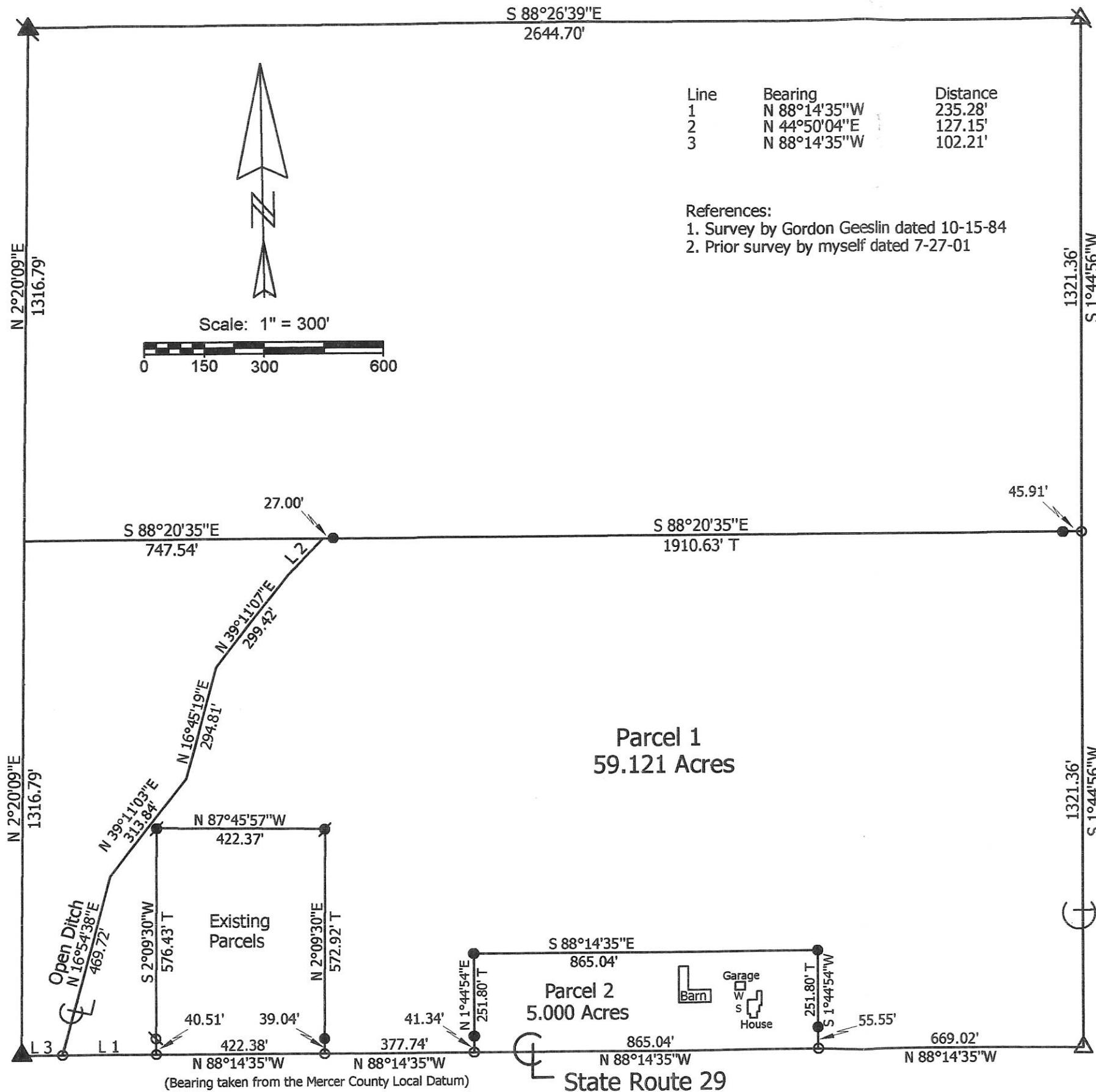

Line	Bearing	Distance
1	N 88°14'35"W	235.28'
2	N 44°50'04"E	127.15'
3	N 88°14'35"W	102.21'

References:
 1. Survey by Gordon Geeslin dated 10-15-84
 2. Prior survey by myself dated 7-27-01

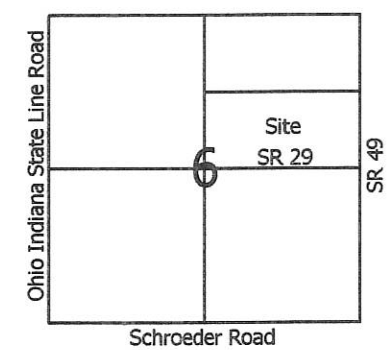

Legend:

- △ Mag nail @ the E1/4 Post of Section 6
- ⊠ Mag nail @ the NE corner of Section 6
- ▲ Cornerstone @ the center of Section 6
- ▲ Calculated corner @ the N1/4 post of Section 6 (68.64' east of the S1/4 post of Section 31, Geeslin)
- 5/8" X 30" Iron pin w/cap set
- Mag nail set
- Iron pin w/cap set by myself in a prior survey
- ⊗ Patented survey stake found
- W Well
- S Existing Septic
- T Total length of line

0706200006

Homan Survey

State of: Ohio County: Mercer

Township: Washington Sec: 6 Town: 6S Range: 1E

City/Village: _____ Subdivision: _____ Lot: _____

Deed References: Inst. # 200500006159 Date Surveyed: 10-28-11

Approvals: _____
 Agency: Board of Health County Engineer: _____
 Date: _____



Marbaugh Land Surveying

1901 Carolina Court
 Celina, Ohio 45822
 (419) 586-4293

Kent Marbaugh
 Kent B. Marbaugh P.S. 7421

BRICHER SURVEY
PART SW 1/4, SEC. 6, T6S, R1E
WASHINGTON TWP., MERCER CO., OHIO

LOCATION PLAT

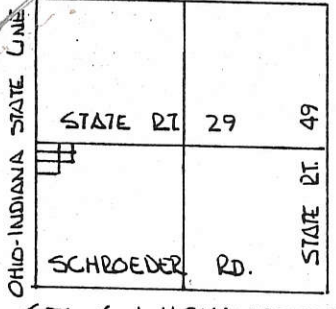

LEGEND.

- SPIKE SET
- IRON PIN SET
- △ STONE REFERENCE
- ⊙ ODOT. REF. MONUMENT.

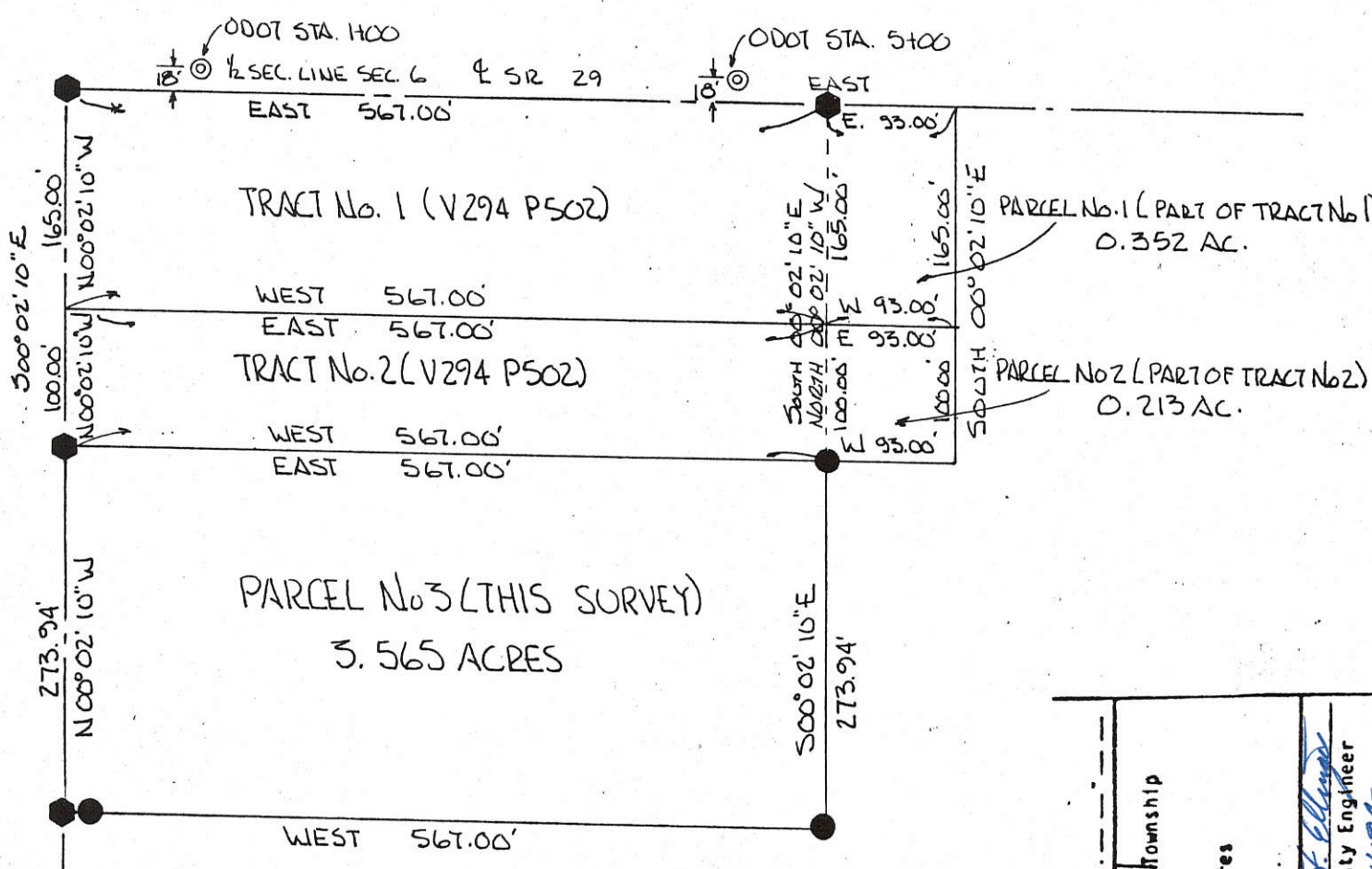
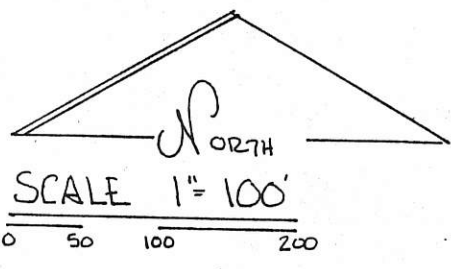

1/2 SEC. LINE SEC. 6 - & SR 29 & WEST 1/4 POST SEC. 6
ESTABLISHED BY USING & REFERENCE MONUMENTS
AS SHOWN - REFER ODOT & SURVEY SR 29 -

PLAT BY SURVEY - MAY 1994 -

Roy F. Thompson Jr.
ROY F. THOMPSON JR. REG SUR #5379

GRANTOR PARCEL No. 1 & No. 2 & GRANTEE PARCEL No. 3
GARY P. & KATHLEEN M. MILLER
GRANTOR PARCEL No. 3 & GRANTEE PARCEL No. 1 & No. 2
ORVAL BRICHER -

PERMANENT PARCEL No.	Part of: <u>SW 1/4</u> Sec. <u>6</u> T <u>6S</u> R <u>1E</u> WASHINGTON Township	
	Grantee: *	Area Retained: _____ Acres
	Grantee: *	Area Transferred: _____ Acres
Deed References: _____		
APPROVALS:	<i>Bruce W. Gearty</i>	County Engineer
AGENCY:	Board of Health	Co. Sanitary Engineer
DATE:	1 JUN 94	6-1-94

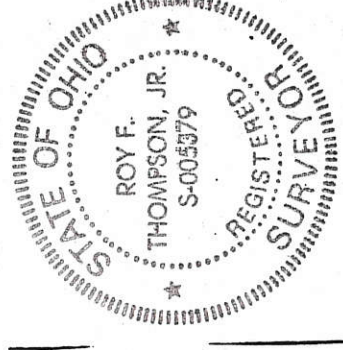

0706300001
0706300002

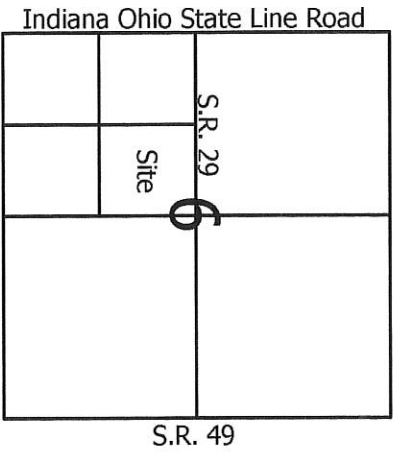

- Legend:**
- ▲ Mag nail @ the SW corner of Section 6
 - △ Mag nail @ the W1/4 post of Section 6
 - Cornerstone @ the center of Section 6
 - ⊕ S1/4 post of Section 6 (Established by Gordon Geeslin)
 - Mag nail set
 - Iron pin with cap set

6706300004
0706300002

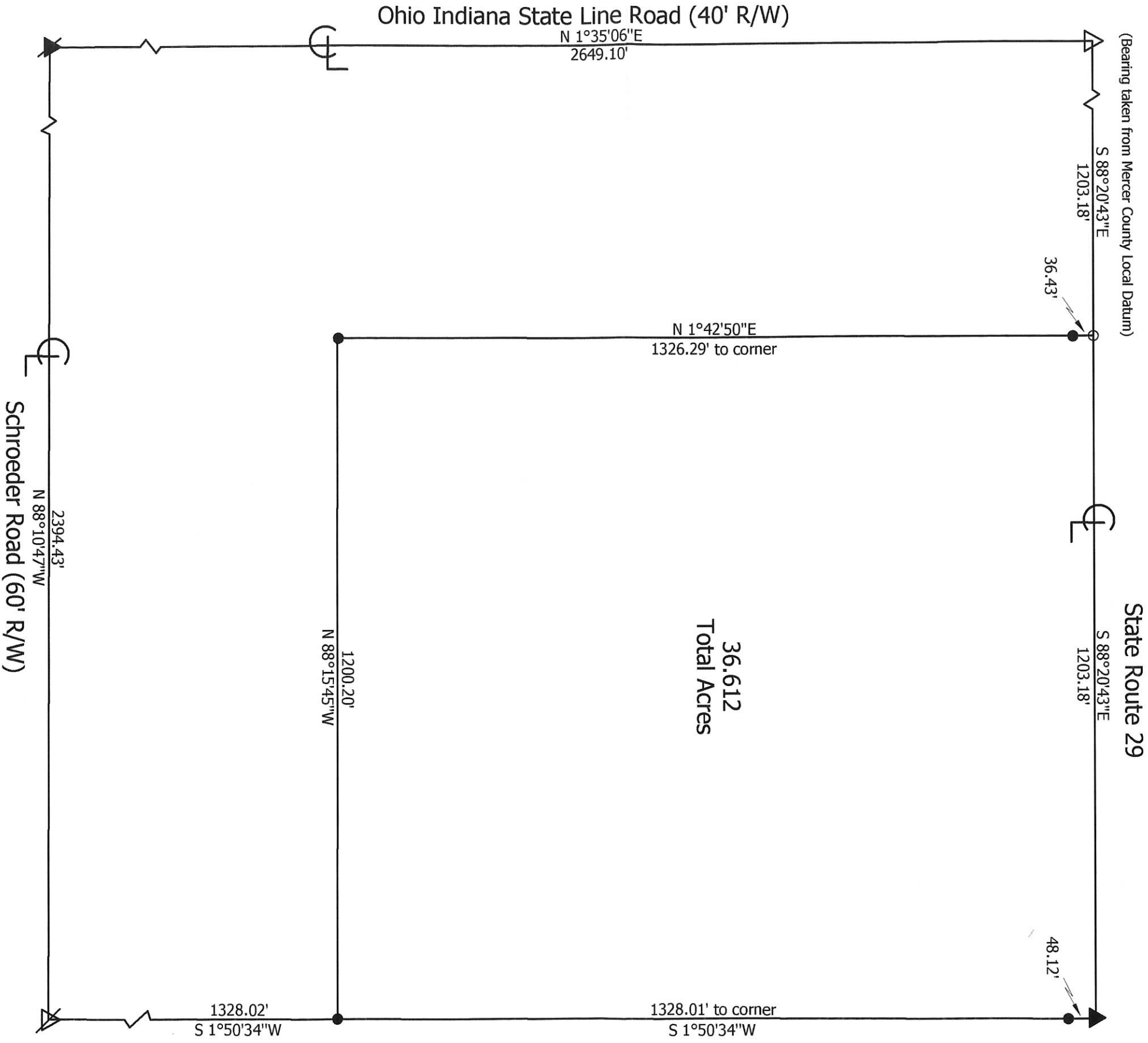
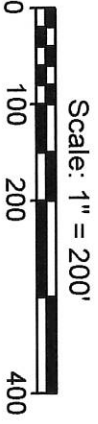
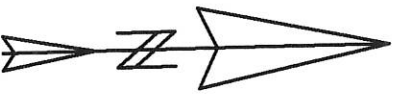

Marbaugh
Land Surveying
1901 Carolina Court
Celina, Ohio 45822
(419) 586-4293
Kent Marbaugh
Kent B. Marbaugh P.S. 7421



Sudhoff Survey

State of: Ohio County: Mercer

Township: Washington Sec: Frac. 6 Town: 6S Range: 1E

City/Village: _____ Subdivision: _____ Lot: _____

Deed References: _____ Inst.#: 200600003701 Date Surveyed: 3-20-10

Approvals: _____ Board of Health _____ Township Zoning Inspector _____ County Engineer _____

Agency: _____ Date: _____

07-A(6)

TERRE SURVEY
 PART SW 1/4, SEC. 6, T6S, R1E, WASHINGTON TWP.
 MERCER, CO., OHIO

07-A

0706400003

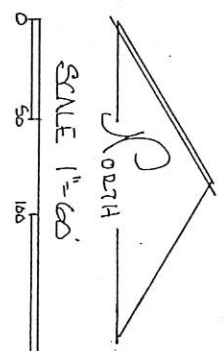
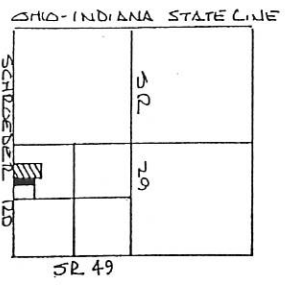

- LEGEND -
- STONE REF.
 - IRON PIN FOUND
 - IRON PIN SET
 - 200 SPIKE FOUND
 - NAIL SET

VOL. 271 Pg 426

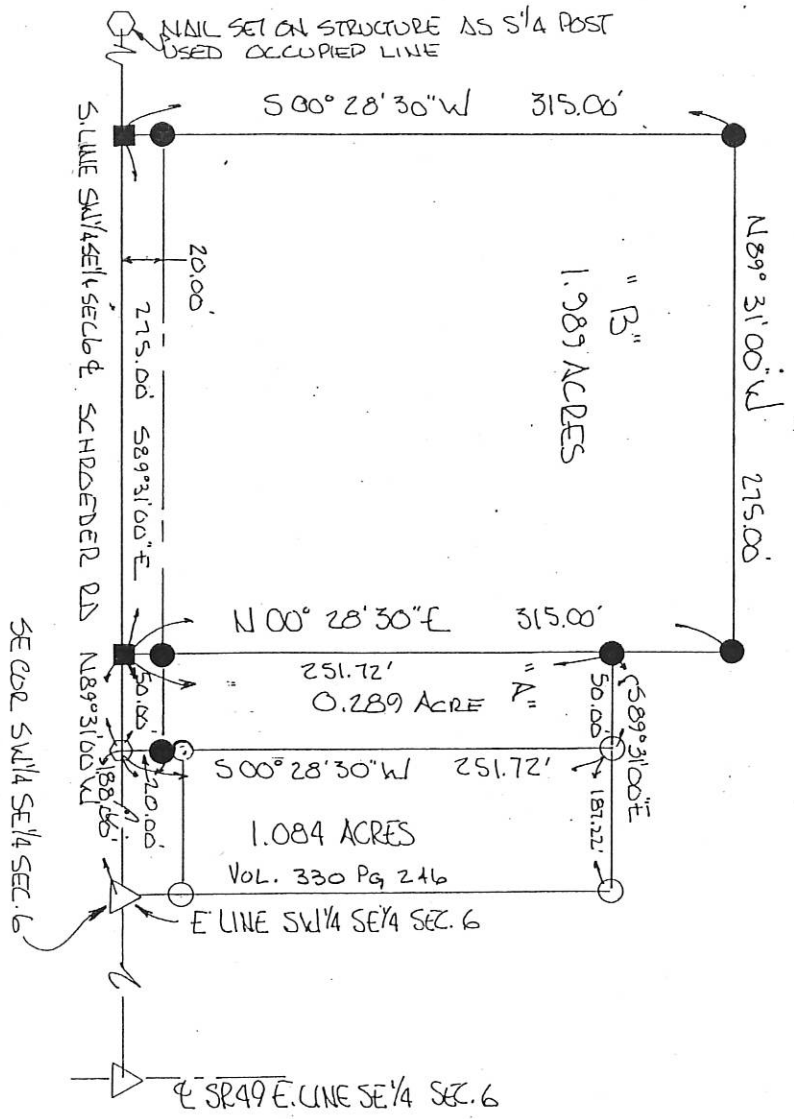

BEARINGS TURNED FROM SOUTH LINE
 SW 1/4 SE 1/4 SEC. 6 EST N89° 31' 00" W.
 ON PREVIOUS SURVEY.

PLAT BY SURVEY MARCH 1999.
 ROY F. THOMPSON SR. REG. SUR * 5379.



PERMANENT PARCEL No. _____		
Part of: <u>5514</u> Sec. <u>6</u> T6S R1E WASHINGTON Township		
Grantor: <u>TERRE</u>	Area Retained: <u>24.638</u> Acres	
Grantee: _____	Area Transferred: <u>2.278</u> Acres	
Deed References: <u>Vol 271 Pg 426</u>		
APPROVALS: <u>Michelle Kimmel</u>		
AGENCY: Board of Health	Co. Sanitary Engineer	County Engineer
DATE: <u>4/6/99</u>		

0706400003; 0706400007

0706400004

**Marbaugh
Land Surveying**

1518 Greenview Drive
Celina, Ohio 45822
(419) 586-4293

Kent Marbaugh
Kent B. Marbaugh P.S. 7421

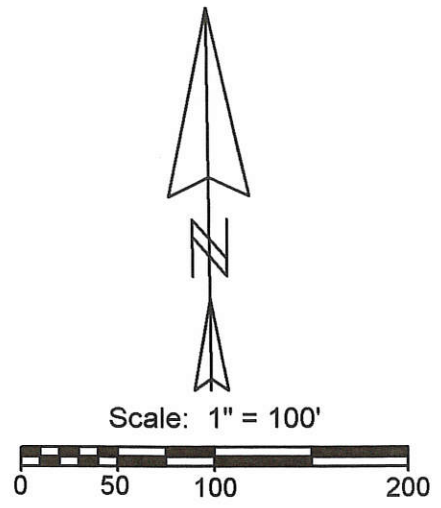
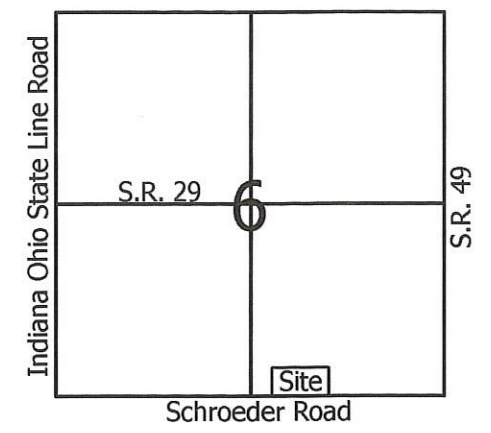
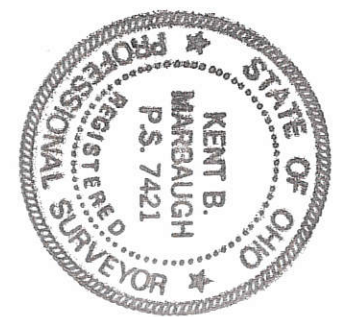

Legend:

- ▲ Cornerstone @ at the SE corner of Section 6
- △ Cornerstone @ the S1/4 post of the SE1/4 of Section 6
- 5/8" X 30" Iron pin w/cap set
- ⊗ Iron pin found (Thompson)
- Mag nail set

Notes: 1. Reference is made to a survey by Gordon Geeslin dated 9-5-89
2. Reference is made to surveys by Roy Thompson dated Sept. 1994 & March 1999

Alvin & Edna Tebbe
Vol. 271, Pg.426

Alvin & Edna Tebbe
Vol. 271, Pg.426

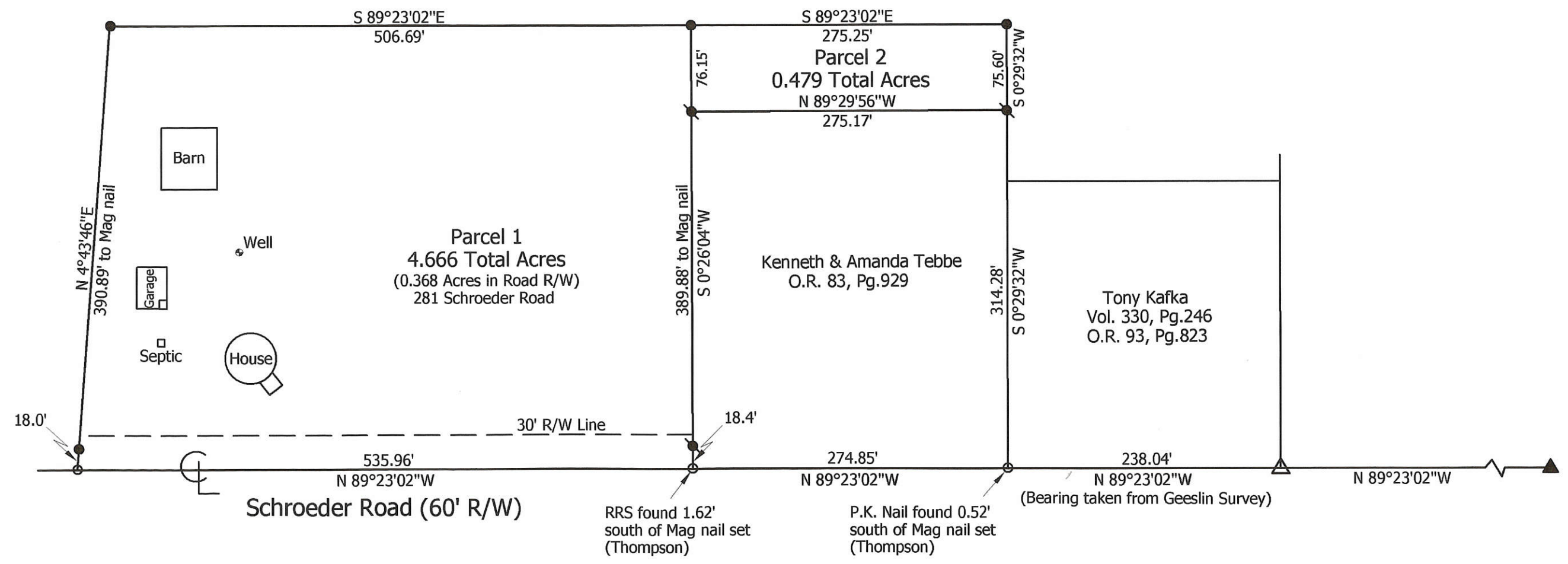

Alvin & Edna Tebbe Survey

State of: Ohio County: Mercer

Township: Washington Sec: 6 Town: 6S Range: 1E

City/Village: _____ Subdivision: _____ Lot: _____

Deed References: Vol. 271, Pg. 426 Date Surveyed: 12-22-06

Approvals: _____
Agency: Board of Health Township Zoning Inspector: _____
Date: _____ County Engineer: _____

Co. Engr

TERBIE SURVEY
PART SW 1/4, SEC. 6, T6S, R1E, WASHINGTON TWP.
MERCER CO., OHIO

0706400004

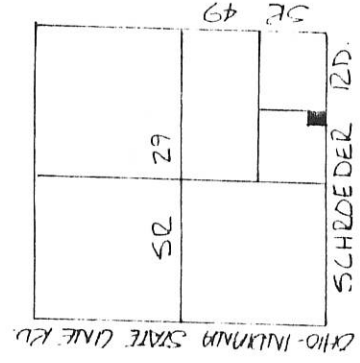

DEED REF. VOL 271 PG. 427

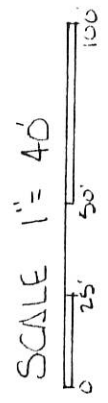
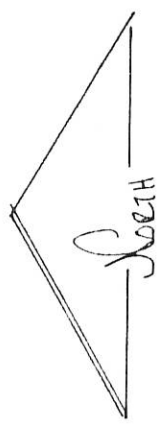

SEC. 6 WASHINGTON TWP.

GRANTORS DEDICATE ADDITIONAL LAND NORTH OF & ADJACENT TO THE EXISTING R/W OF THE SCHROEDER RD. TO CREATE A THIRTY (30.00) FOOT R/W ALONG THIS PARCEL.

LEGEND

- △ STONE REF.
- IRON PIN SET
- RR SPIKE SET
- NAIL SET



ALVIN W. TERBIE, GRANTOR DATE

EDNA D. TERBIE, GRANTOR DATE

PLAT BY SURVEY SEPT 1994 -

Roy F. Thompson Jr.
ROY F. THOMPSON JR., REG. SUR# 5379.

NAIL SET ON STRUCTURE AS S 1/4 POST SEC. 6 - USED
OCCUPIED &

BEARINGS TURNED OFF SOUTH LINE SE 1/4 SEC. 6
EST. N 89° 23' 02" W BY GEESON ON PREVIOUS SURVEY -

PERMANENT PARCEL No. _____

Part of: SE 1/4 Sec. 6 T6S R1E WASHINGTON Township

Grantor: TERBIE

Grantee: _____

Area Retained: 36.916 Acres

Area Transferred: 1.084 Acres

Deed References: Vol. 271 Pg. 427

APPROVALS:

AGENCY: Board of Health

DATE: _____

Co. Sanitary Engineer _____

County Engineer _____

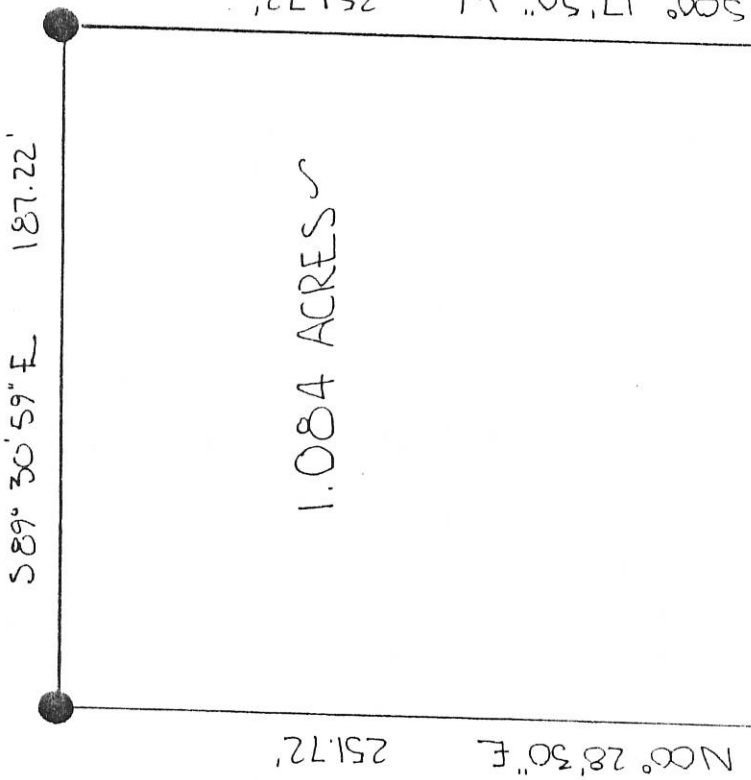

30' DEDICATED R/W

30.00' 20' OCCUPIED R/W

SOUTH LINE SEC. 6
SCHROEDER RD.

SE COR. SEC. 6

N 89° 23' 02" W
SE COR SW 1/4 SE 1/4 SEC. 6

500' 17' 50" W 251.72'

TERPBE SURVEY
 PART SW 1/4, SE 1/4, SEC. 6, T6S, R1E, WASHINGTON TWP.
 MERCER, CO., OHIO

0706400007

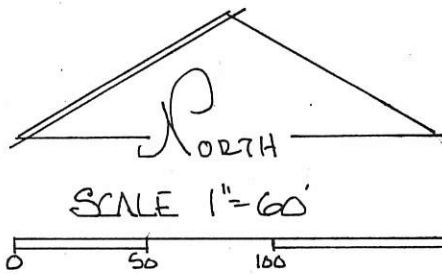
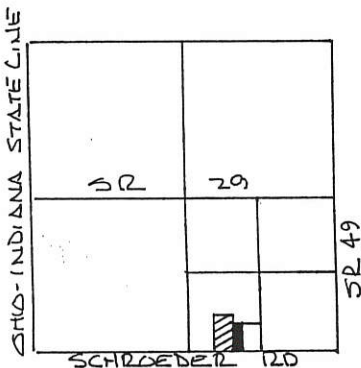

LEGEND -

- STONE REF.
- IRON PIN FOUND
- IRON PIN SET
- SPIKE FOUND
- NAIL SET

VOL. 271 Pg 426

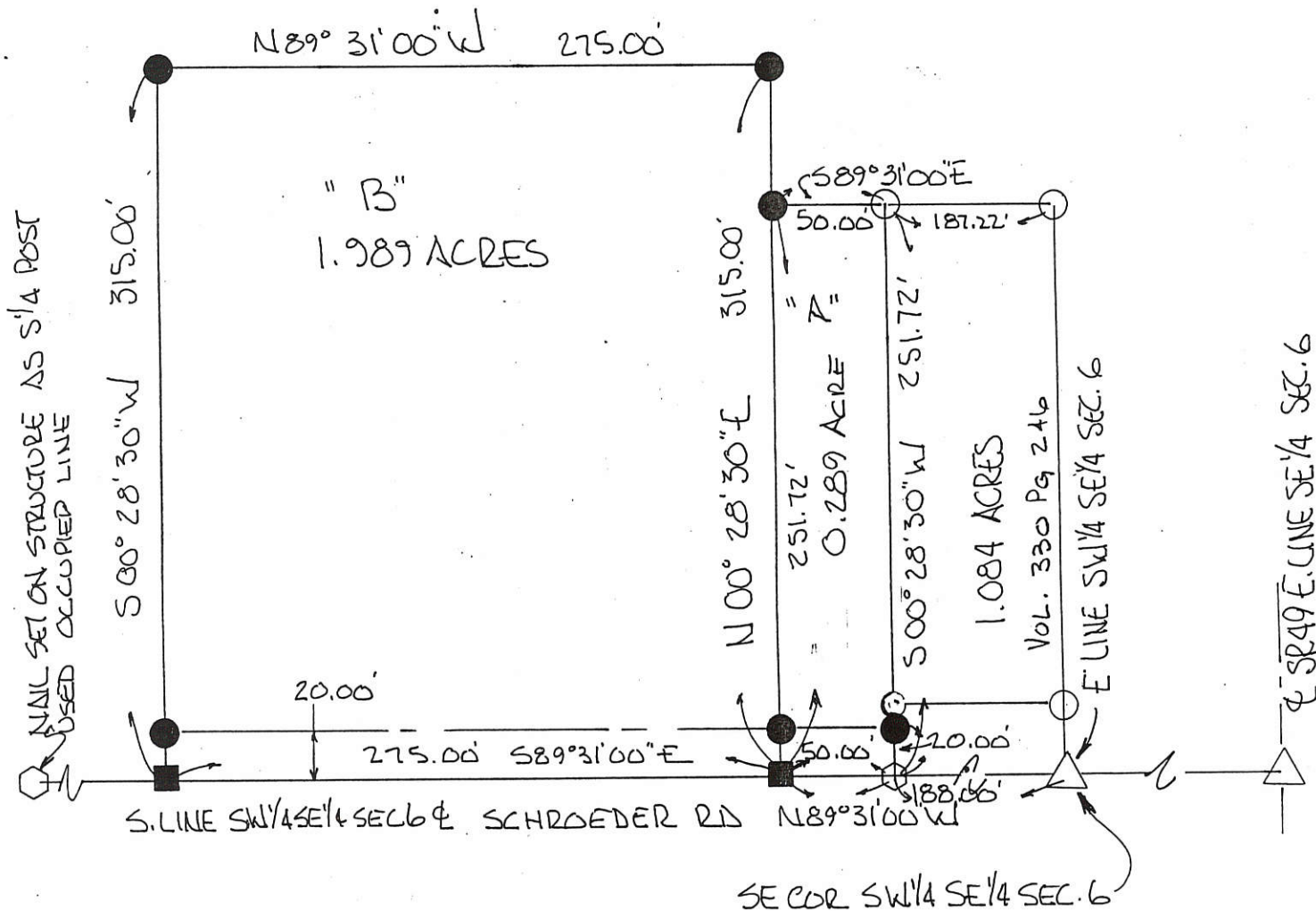

BEARINGS TURNED FROM SOUTH LINE
 SW 1/4 SE 1/4 SEC. 6 EST N 89° 31' 00\"/>

PLAT BY SURVEY MARCH 1999.

ROY F. THOMPSON JR. REG. SUR # 5379.



PERMANENT PARCEL No.	
Part of: 55/4 Sec. 6 T6S R1E WASHINGTON Twp	
Grantor: TERPBE	Area Retained: 34.638 Acres
Grantee:	Area Transferred: 2.278 Acres
Deed References: Vol. 271 Pg 426	
APPROVALS: <i>Michelle Kumona</i>	Co. Sanitary Engineer
AGENCY: Board of Health	County Engineer
DATE: 4/6/99	

070620004
070620005

HOMAN SUB-DIVISION

PT. SW 1/4 NE 1/4 FRAC. SECTION 6,
T6S, R1E, WASHINGTON TOWNSHIP
MERCER CO., OHIO

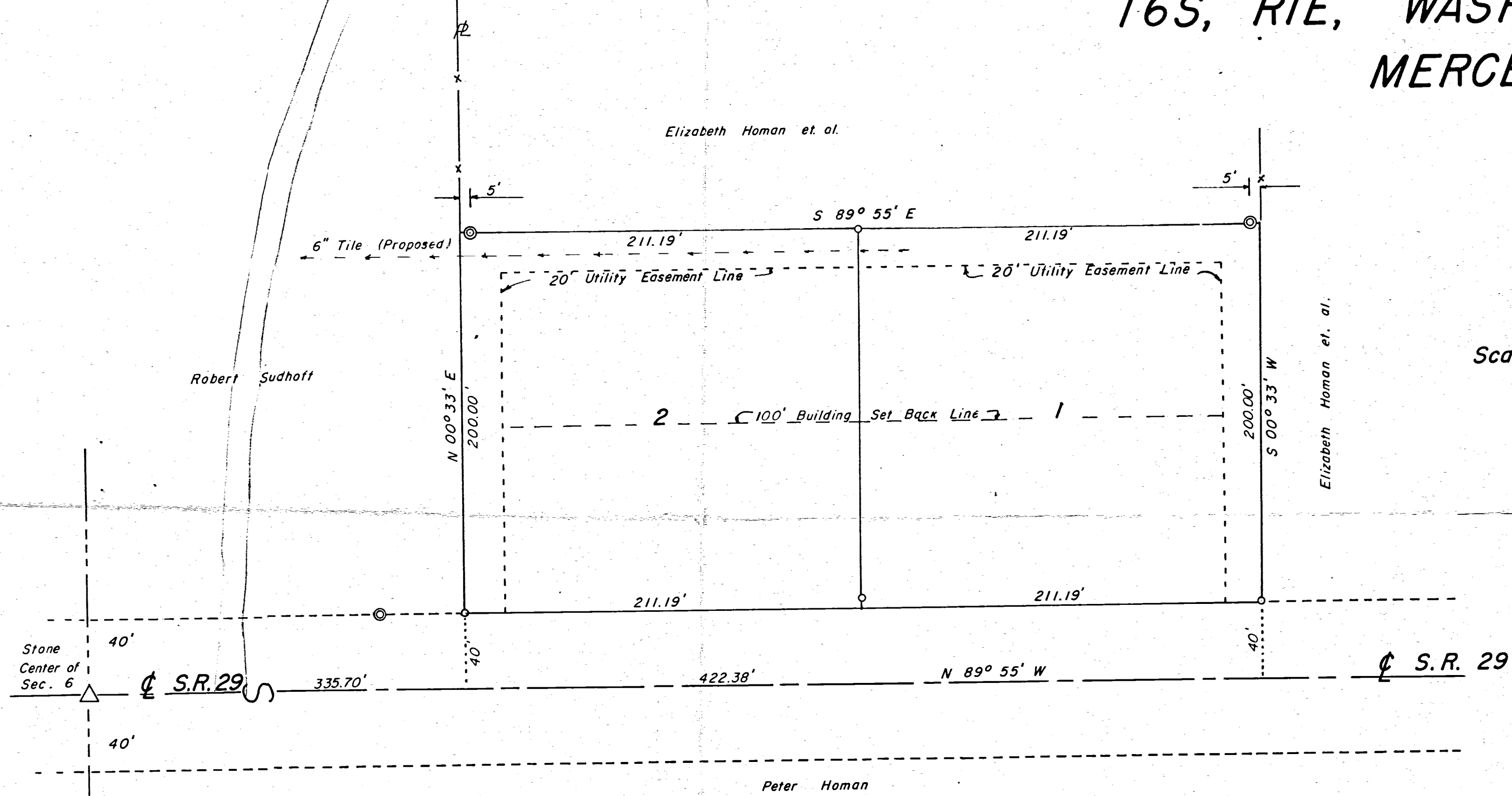

Scale: 1" = 50'

- Legend:
- Concrete Monument
 - Patented Iron Survey Stakes

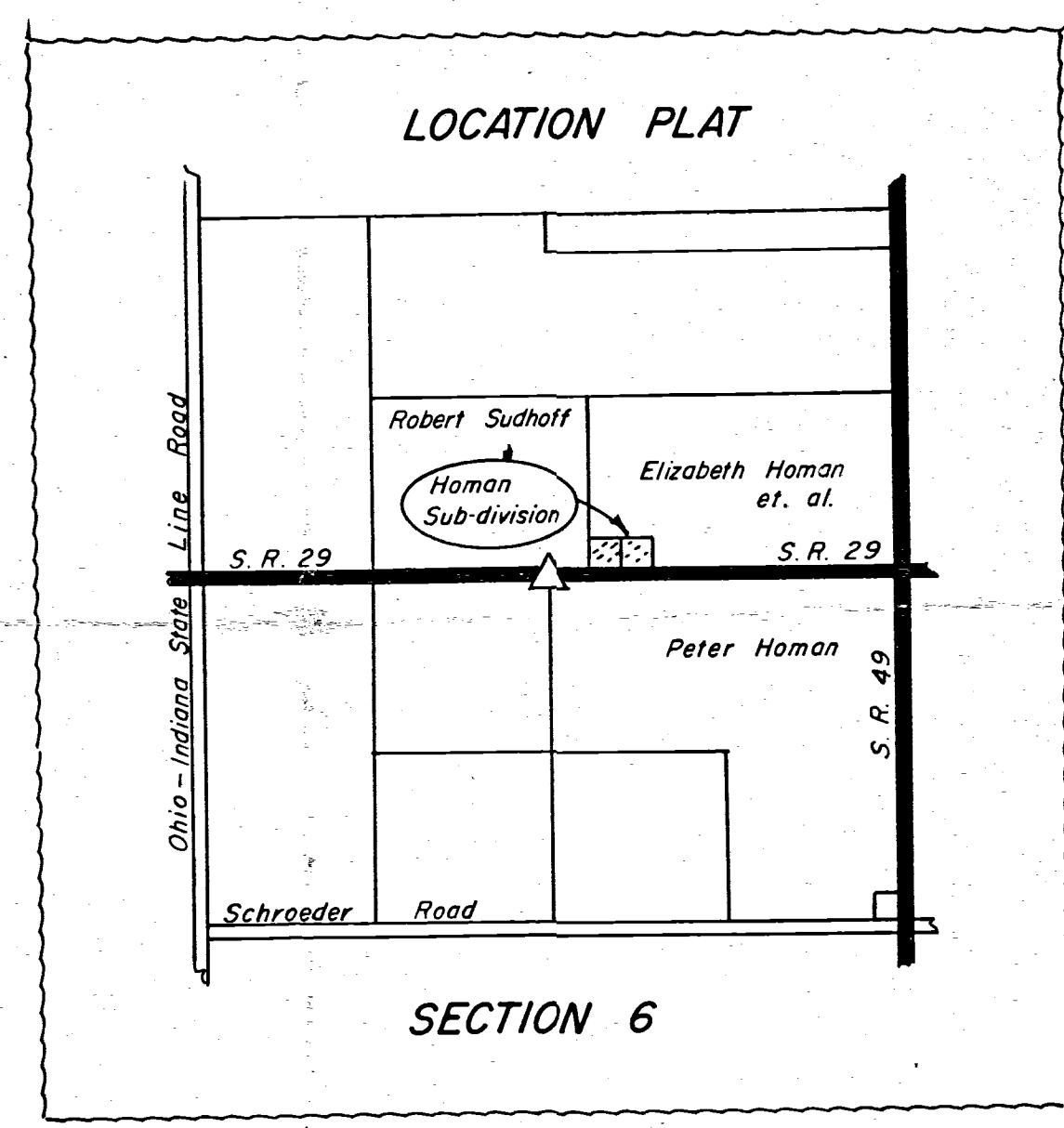

SURVEYOR'S CERTIFICATE:

To all persons interested in the area contained, I hereby certify this plat and survey to be correct to the best of my knowledge and belief. Plat consists of two (2) lots located in the South side of the South half of the Northeast quarter of Section 6, T6S, R1E, Washington Township, Mercer County, Ohio and more definitely described as follows.

Beginning at a point in the centerline of S.R. 29 (East and West centerline of Section 6) a distance of three hundred thirty five and seventy hundredths (335.70) feet S 89° 55' E of the center of Section 6; thence N 00° 33' E a distance of two hundred forty (240.00) feet to a point; thence S 89° 55' E parallel to the half section line a distance of four hundred twenty two and thirty eight hundredths (422.38) feet to a point; thence S 00° 33' W a distance of two hundred forty (240.00) feet to a point in the centerline of S.R. 29; thence N 89° 55' W on and along the centerline of the road a distance of four hundred twenty two and thirty eight hundredths (422.38) feet to the place of beginning. Concrete monuments and iron stake markers are set as shown.

The above described tract contains two and thirty three hundredths (2.33) acres of land, subject to a forty (40.00) foot strip of land along the entire South side, being the present right of way of S.R. 29 and heretofore dedicated for road purposes.

10/11/68
Date

B.R. Gebhart
B.R. Gebhart, Registered Surveyor No. 3909
204 Dogwood Drive Celina, Ohio

10-11-68
E.J.B.

OWNER'S DEDICATION:

Know all men by these presents that we, the undersigned owners, of the within described land, have caused the area encompassed by this plat to be surveyed, platted and to be known as the "HOMAN SUB-DIVISION", and do hereby certify that said plat is a true representation of the same.

Signed this 9th day of October 1968.

<u>Elizabeth Homan</u> Elizabeth Homan, R.R. 1, Celina, Ohio	<u>Madonna V. Homan</u> Madonna V. Homan, R.R. 1, Celina, Ohio
<u>Lueella J. Homan</u> Lueella J. Homan, R.R. 1, Celina, Ohio	<u>Walter J. Homan</u> Walter J. Homan, R.R. 1, Celina, Ohio
<u>Anna Marie Homan</u> Anna Marie Homan, R.R. 1, Celina, Ohio	<u>Wilfred F. Homan</u> Wilfred F. Homan, 204 Hillcrest Drive, Coldwater, Ohio

ACKNOWLEDGEMENT:

Before me, a Notary Public, in and for said County of Mercer, personally appeared the above signed owners and acknowledged the signing of the fore going instrument to be their free act and deed.

In testimony whereof, I have affixed my hand and seal this 9th day of October 1968.

LEE A. KUHN
NOTARY PUBLIC, Mercer Co., Ohio
My Commission Expires 8/6/69
Lee A. Kuhn

COUNTY COMMISSIONER'S ACCEPTANCE:

We hereby certify that the plat shown hereon has been found to comply with the SUB-DIVISION REGULATIONS OF MERCER COUNTY, OHIO and that we hereby approve same for recording in the Office of the Mercer County Recorder.

October 11th 1968
Date
Board of County Commissioners
MERCER COUNTY, OHIO
Lester J. Brandewie
George J. Pihl
John P. Suber

COUNTY AUDITOR'S CERTIFICATE:

I hereby certify that there are no unpaid taxes on this land comprising the HOMAN SUB-DIVISION, and that this plat was filed for transfer in the Office of the MERCER COUNTY AUDITOR this 11 day of October 1968.

Tom Timmerman
Mercer County Auditor

COUNTY ENGINEER'S RECOMMENDATION:

Having reviewed this plat of the "HOMAN SUB-DIVISION", I hereby certify compliance with the Mercer County Sub-Division Regulations and recommend acceptance for recording as presented.

10/11/68
Date
B.R. Gebhart
Mercer County Engineer

COUNTY RECORDER'S CERTIFICATE:

Received for recording this 11 day of October, 1968 at 10:05 AM o'clock and is recorded in Plat Book 9, page 48. Fees paid 7.50.

Gertrude M. Cain
Mercer County Recorder

RESTRICTIONS:

- No building other than one for residential purposes and attached garage or carport for same, shall be permitted, or constructed, on any one lot. All homes shall have a minimum of 1200 square feet of living area on the ground floor.
- No trailer, basement, garage or other outbuilding shall be used as a residence, temporary or permanent, nor shall any residence of a temporary character be permitted on any lot within this sub-division.
- The building lines indicated on this plat shall be strictly adhered to and no building may be erected nearer the road, or adjacent lot lines, than any building lines so established.
- Easements and right of ways as shown on the plat are expressly reserved in and over said lots for construction and maintenance of necessary utilities, drains etc. Easements as shown are to be used without incurring any liability from property owners for damage to sod, shrubbery, trees, fences or any other surface improvements.
- No fence shall be built between the road and the building lines to a height of more than three (3) feet.
- No garbage, waste or trash shall be dumped on any lot and all such garbage, waste or trash shall be kept in sanitary containers until proper disposal is made thereof.
- None of the property within this sub-division may be used for industrial or commercial purposes nor shall any industrial or commercial buildings be permitted on any lots within this sub-division.
- There shall be no kennels, breeding or raising of any animals within this area.
- The conditions, limitations and restrictions set forth herein shall be considered part of any contract, deed, lease or instrument relating to any lot in the HOMAN SUB-DIVISION without being incorporated therein, and the acceptance of any contract, deed, lease or instrument relating thereto shall operate as a covenant to use the premises in conformity with conditions, limitations and restrictions herein set forth. These conditions, limitations and restrictions shall run with the land and shall be considered conditions subsequent.
- All water and sanitary facilities are to be provided by the individual owners of the lots and must comply with all regulations of the County and State Health Departments.

0706200004; 0706200005

PRELIMINARY PLAT
 HOMAN SUB-DIVISION
 PT. SW 1/4 NE 1/4 SECTION 6
 T6S, R1E, WASHINGTON TWP.
 MERCER CO., OHIO

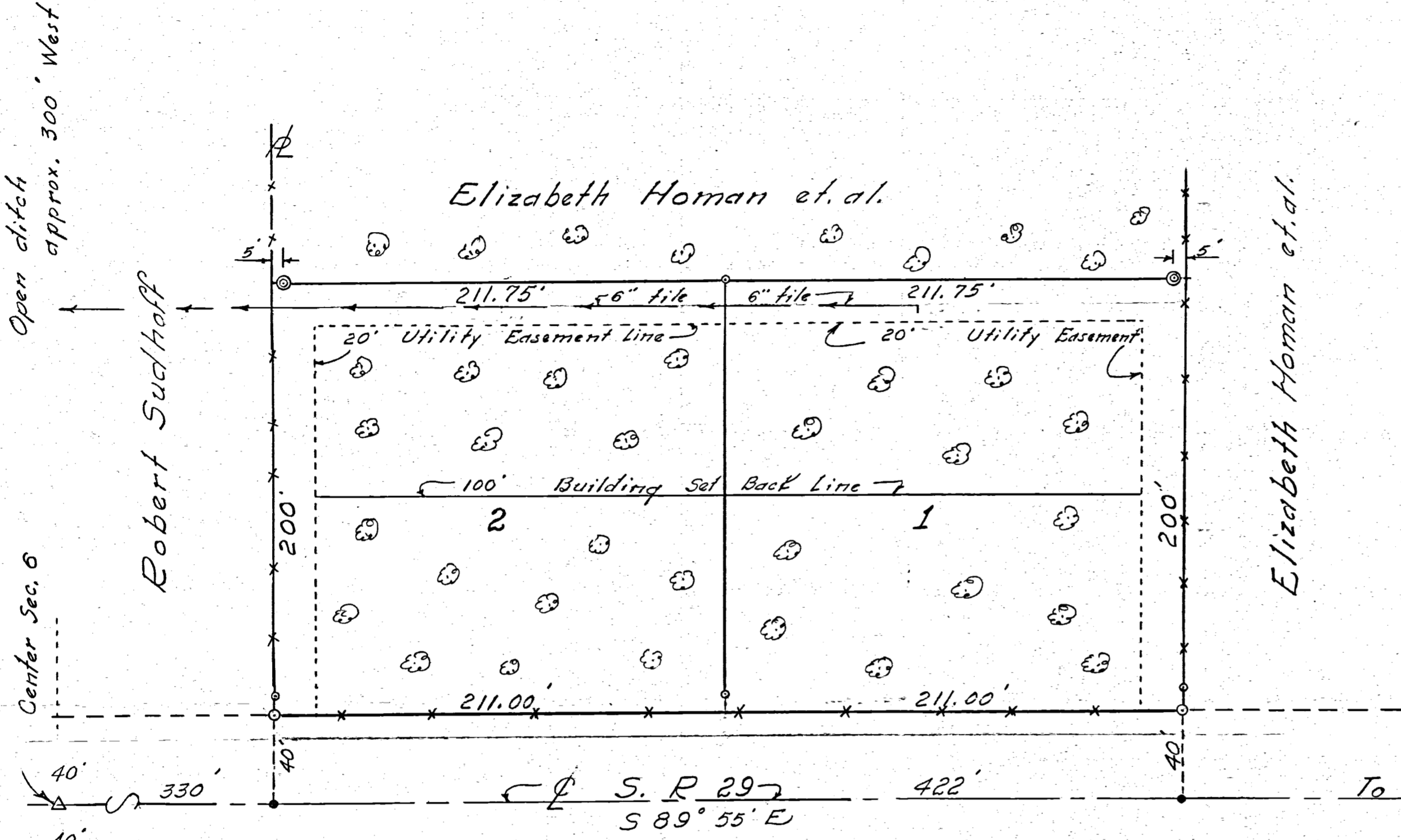

Scale: 1" = 50'
 Legend:
 Δ Section Stone
 ⊙ Con. Mon.
 ○ Iron Stakes

Peter Homan

HOMAN SUB-DIVISION:

The following named owners of the tract of land comprising this proposed Sub-division respectfully submit this proposed PRELIMINARY PLAT for approval for final platting.

Elizabeth Homan
 Elizabeth Homan, R.R. 1, Celina, O.

Madonna V. Homan
 Madonna V. Homan, R.R., Celina, O.

Luella J. Homan
 Luella J. Homan, R.R. 1, Celina, O.

Walter J. Homan
 Walter J. Homan, R.R. 1, Celina, O.

Anna Marie Homan
 Anna Marie Homan, R.R. 1, Celina, O.

Wilfred F. Homan
 Wilfred F. Homan, R.R. 1, Yorkshire, O.
 204 HILLCREST DR., COLDWATER, O.

DESCRIPTION:

Beginning at a point in the centerline of S.R. 29 (East & West centerline of Section 6) a distance of three hundred thirty (330.00) feet S 89° 55' E of the center of Fractional Section 6, T6S, R1E, Washington Township; thence Northerly along an existing property line between Robert Sudhoff and Elizabeth Homan, et. al. a distance of two hundred forty (240.00) feet to a point; thence S 89° 55' E a distance of four hundred twenty three and fifty hundredths (423.50) feet to a point; thence Southerly a distance of two hundred forty (240.00) feet to a point in the centerline of S.R. 29; thence N 89° 55' E on and along the centerline of S.R. 29 a distance of four hundred twenty two (422.00) feet to the place of beginning.

The above described tract is divided into two Lots numbered one (1) and two (2) and being of uniform size as shown on the plat.

Tract contains two and thirty three hundredths (2.33) acres of land subject to a forty (40.00) foot strip along the entire South side, being the present right of way of S.R. 29 and hereby dedicated for road purposes.

All water and sanitary facilities are to be provided by the individual owners of the lots and must comply with all regulations of the County and State Health Departments.

SURVEYOR'S CERTIFICATE:

I hereby certify this survey showing section stones, concrete markers, iron survey stakes and property lines to be correct to the best of my knowledge and belief.

8/30/68
 Date

B.R. Gebhart
 B.R. Gebhart, Reg. Sur. #3909, 204 Dogwood, Celina, Ohio

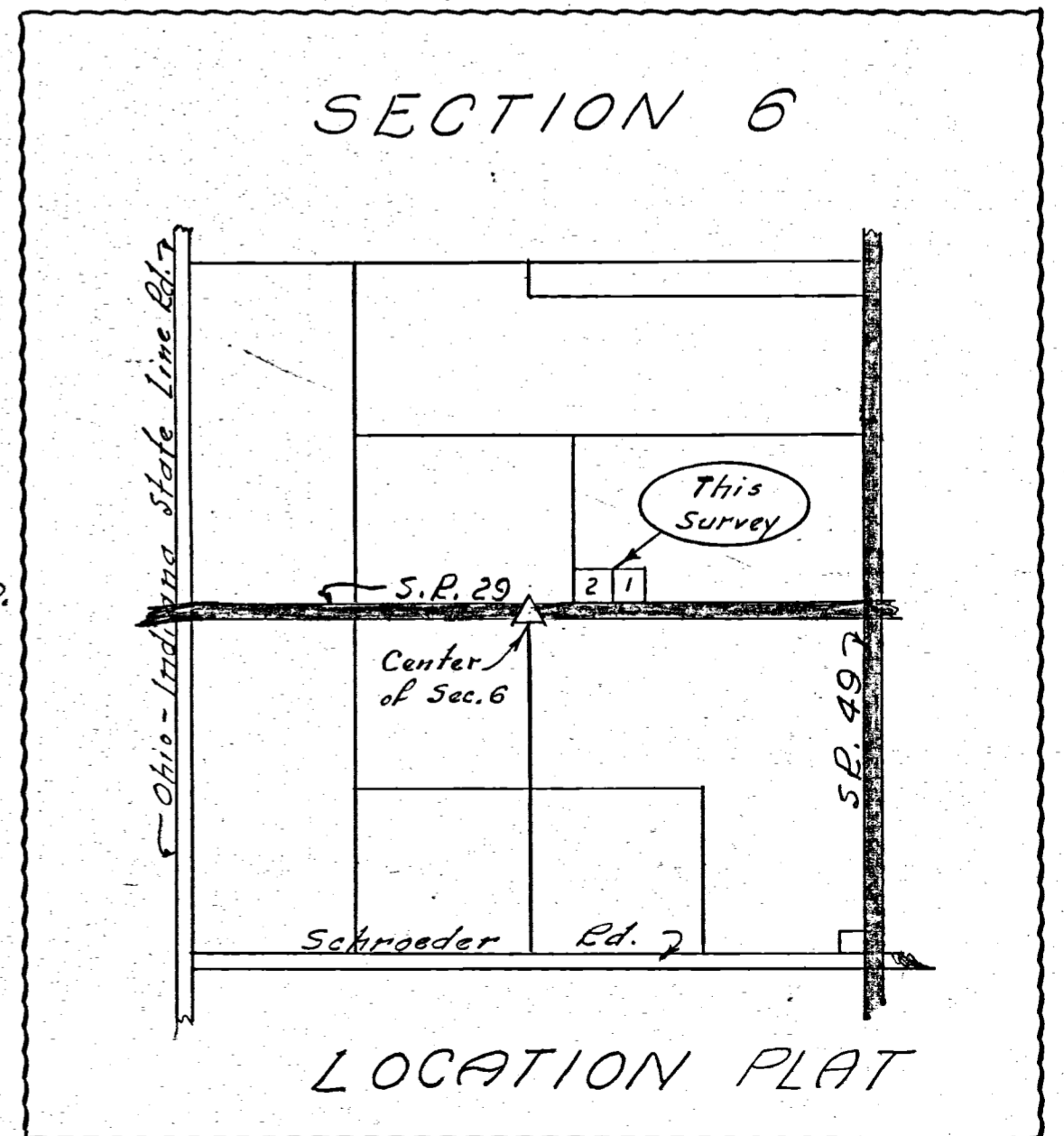

APPROVED FOR FINAL PLATTING:

Sept 10, 1968
 Date

Leslie Brandewie
George J. Fisher
John R. Suber

MERCER COUNTY
 BOARD OF COUNTY
 COMMISSIONERS

0706400005
0706400001

LOCATION SKETCH

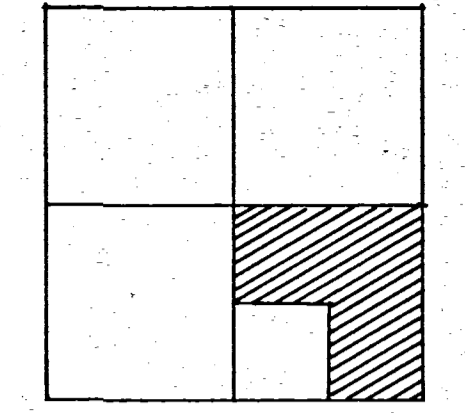

SECTION 6

PRIOR DEED REFERENCE ~ VOL. 290, PG. 614

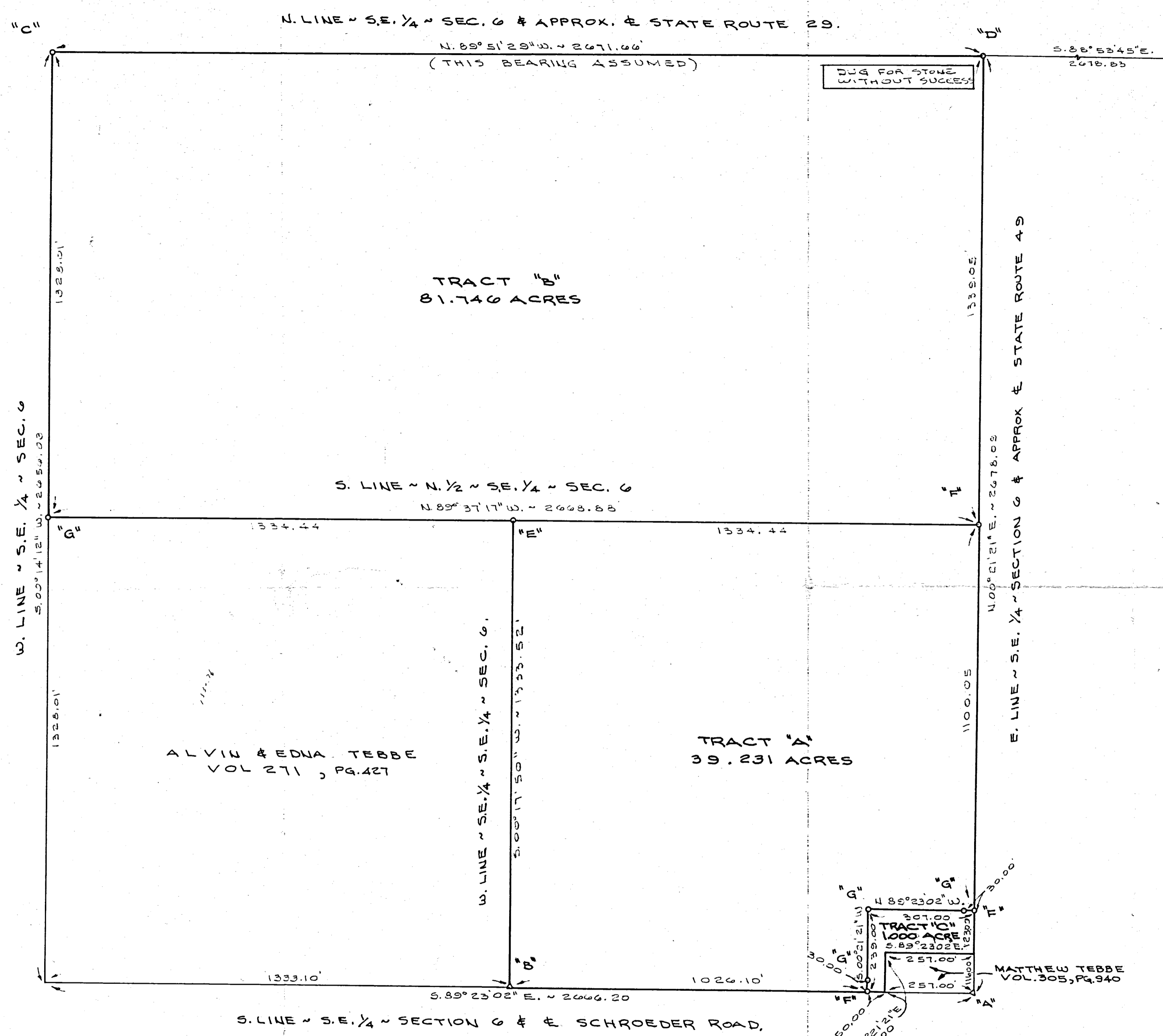

LEGEND

- "X" = COR. STONE AT S.E. COR. ~ SEC. 6 (SEE STATE RECORDS)
- "N" = COR. STONE AT S.W. COR. ~ S.E. 1/4 ~ SEC. 6. (SEE SURVEY BY THIS SURVEYOR IN SEC. 7, DATED DEC. 26, 1986.)
- "O" = MINE SPIKE SET AT CENTER OF SEC. 6. (SEE SURVEY BY THIS SURVEYOR DATED APRIL 27, 1984)
- "U" = RAILROAD SPIKE SET AT N.E. COR. ~ S.E. 1/4 ~ SEC. 6 BY PROTRACTING FROM SCHUYLER SURVEYS RECORDED IN SURVEY BOOK 1, PAGES 120 (SEC. 5) & 353 (SEC. 6).
- "E" = 5/8" X 30" IRON BAR SET AT CENTER OF S.E. 1/4 ~ SEC. 6. (FD. COR. STONE 23" X 10" X 6" DISTURBED & ON TOP OF GROUND)
- "T" = MINE SPIKE SET BY THIS SURVEY.
- "G" = 5/8" X 30" IRON BAR SET BY THIS SURVEY.

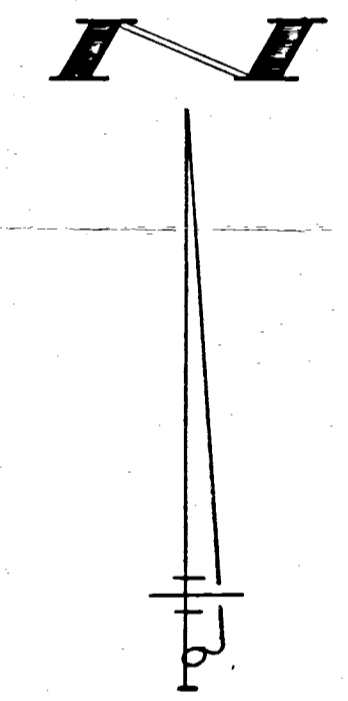

SURVEYED BY Gordon L. Geeslin
GORDON L. GEESLIN
REGISTERED SURVEYOR
NO 5372

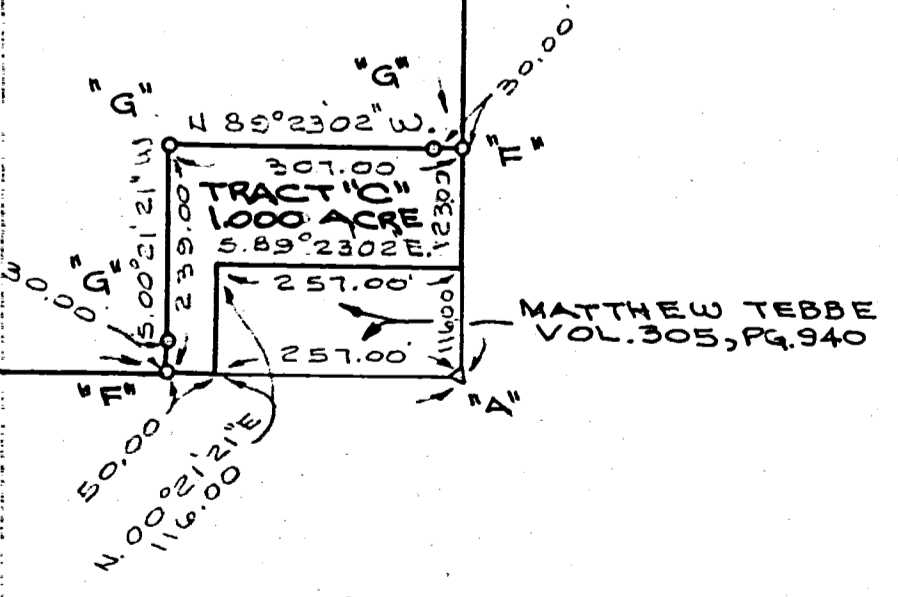

HUELSMAN SURVEY
PART OF THE S.E. 1/4 OF SECTION 6, TOWN 6
SOUTH, RANGE 1 EAST (WASHINGTON TOWNSHIP),
MERCER COUNTY, OHIO

SEPT. 5, 1989

SCALE 1" = 200'

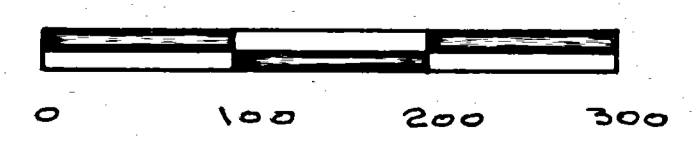

FILED IN SURVEY BOOK

0706300001
0706300002

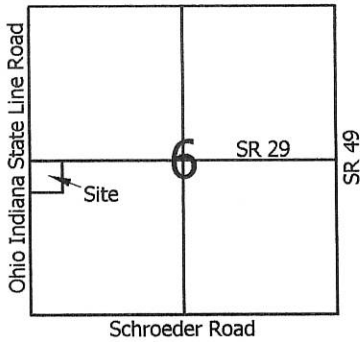

Scale: 1" = 100'

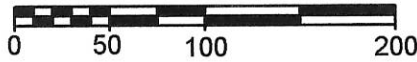

- Legend:**
- △ Mag nail @ the SW corner of Section 6
 - ▲ P. K. nail @ the W1/4 post of Section 6
 - 5/8" X 30" Iron pin w/cap set
 - Mag nail set
 - ⊙ Iron pin found (Thompson)
 - ⊗ Railroad spike found (Thompson)

1 Lot
MINOR SUBDIVISION
Carl Miller 8/21/13
Approved No Plat Required
For A Major Subdivision

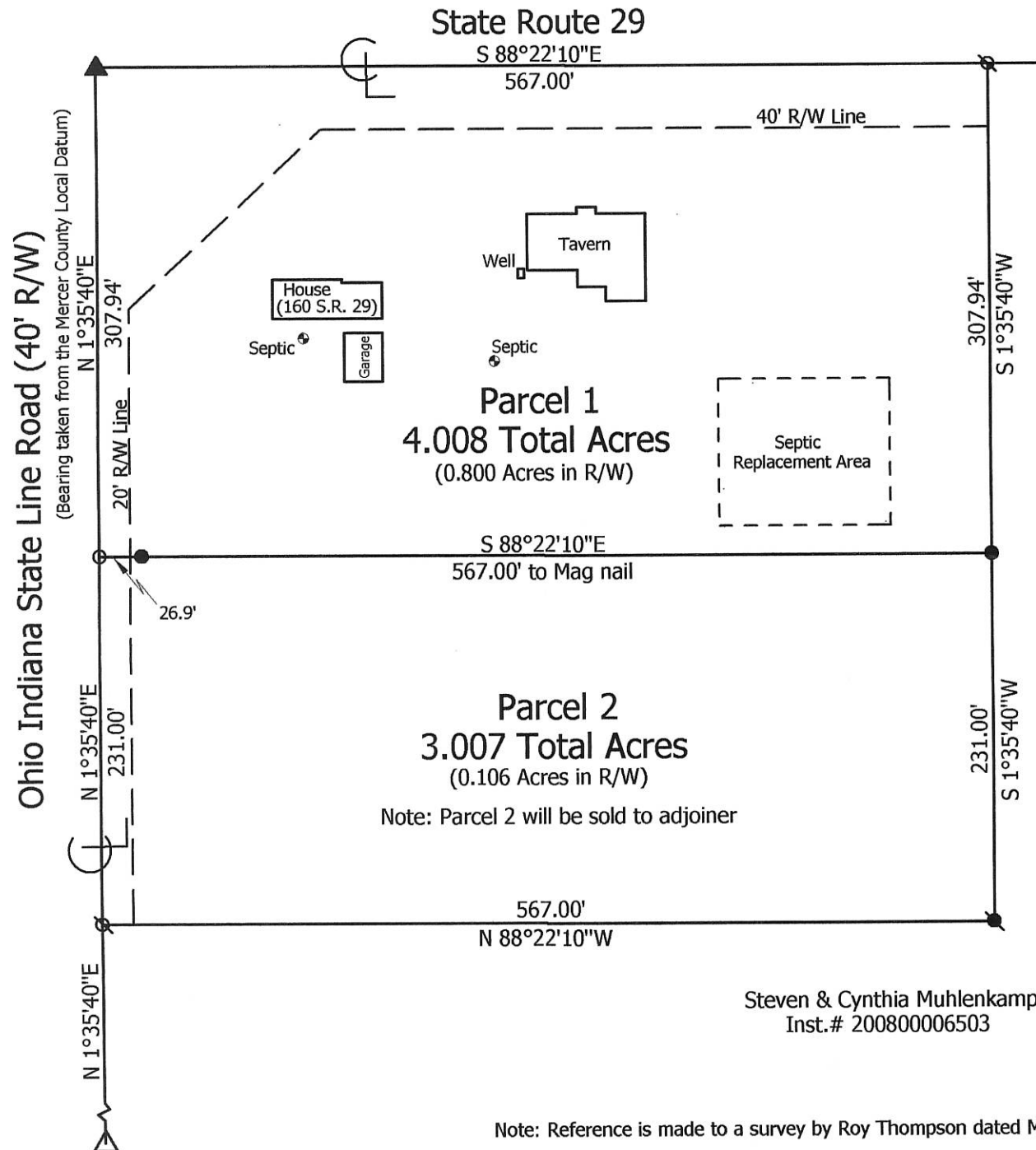

Note: Reference is made to a survey by Roy Thompson dated May 1994

Marbaugh Land Surveying

1901 Carolina Court
Celina, Ohio 45822
(419) 586-4293

Kent Marbaugh
Kent B. Marbaugh P.S.7421



Miller Survey

State of: Ohio County: Mercer
Township: Washington Sec: 6 Town: 6S Range: 1E
City/Village: _____ Subdivision: _____ Lot: _____
Deed Ref: Inst.# 200500001316 Date Surveyed: 8-3-13

Approvals: *James Fendley* Township Zoning Inspector
Agency: Board of Health Date: 8-21-13
Mike Borneo County Engineer Date: 8-15-13

07-A(6)