

05-18-10-001

LOCATION SKETCH

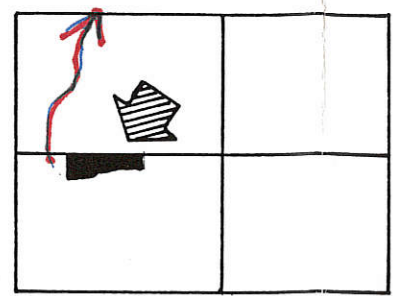

SECTION 18

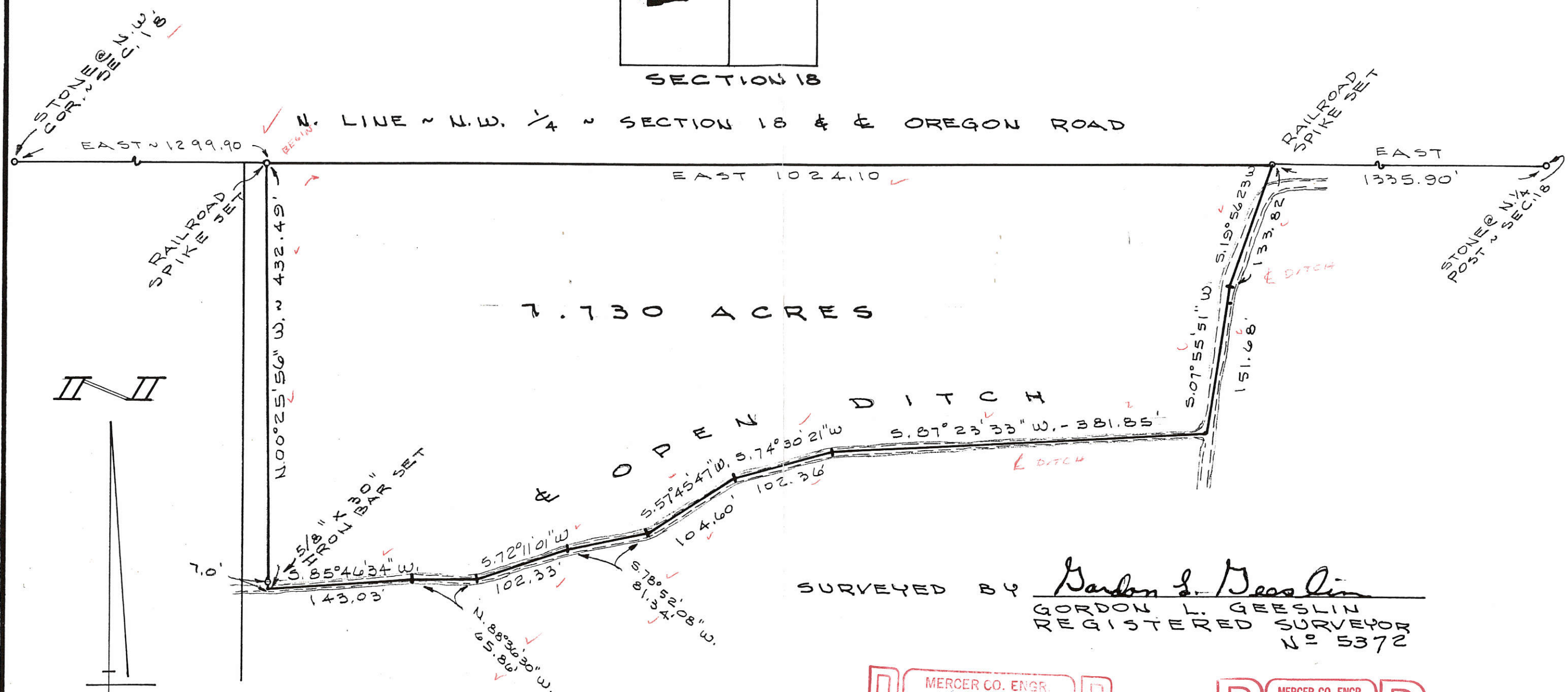

7.730 ACRES

SURVEYED BY Gordon L. Geeslin
GORDON L. GEESLIN
REGISTERED SURVEYOR
No 5372



WILLRATH SURVEY

PART OF THE N.W. 1/4 OF SECTION 18, TOWN 5 SOUTH, RANGE 2 EAST (HOPEWELL TWP.), MERCER COUNTY, OHIO.

MAY 2, 1986

SCALE 1" = 100'

LEGEND

- "A" = STONE N^o 412 @ N. 1/4 POST ~ SECTION 18.
- "B" = STONE N^o 425 @ N.W. COR. ~ SECTION 18.
- "C" = MINE SPIKE SET.
- "D" = 5/8" x 30" IRON BAR SET.

LOCATION SKETCH

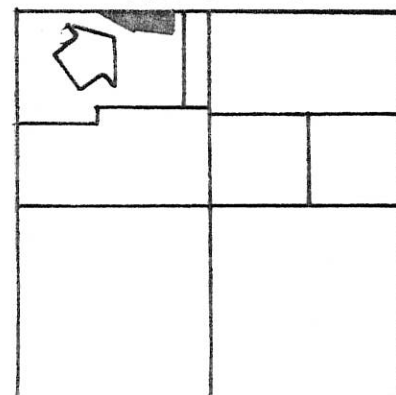

SECTION 18

SURVEYED BY Norton E. Dees
GORDON L. GEESLIN
 REGISTERED SURVEYOR
 N^o 5372

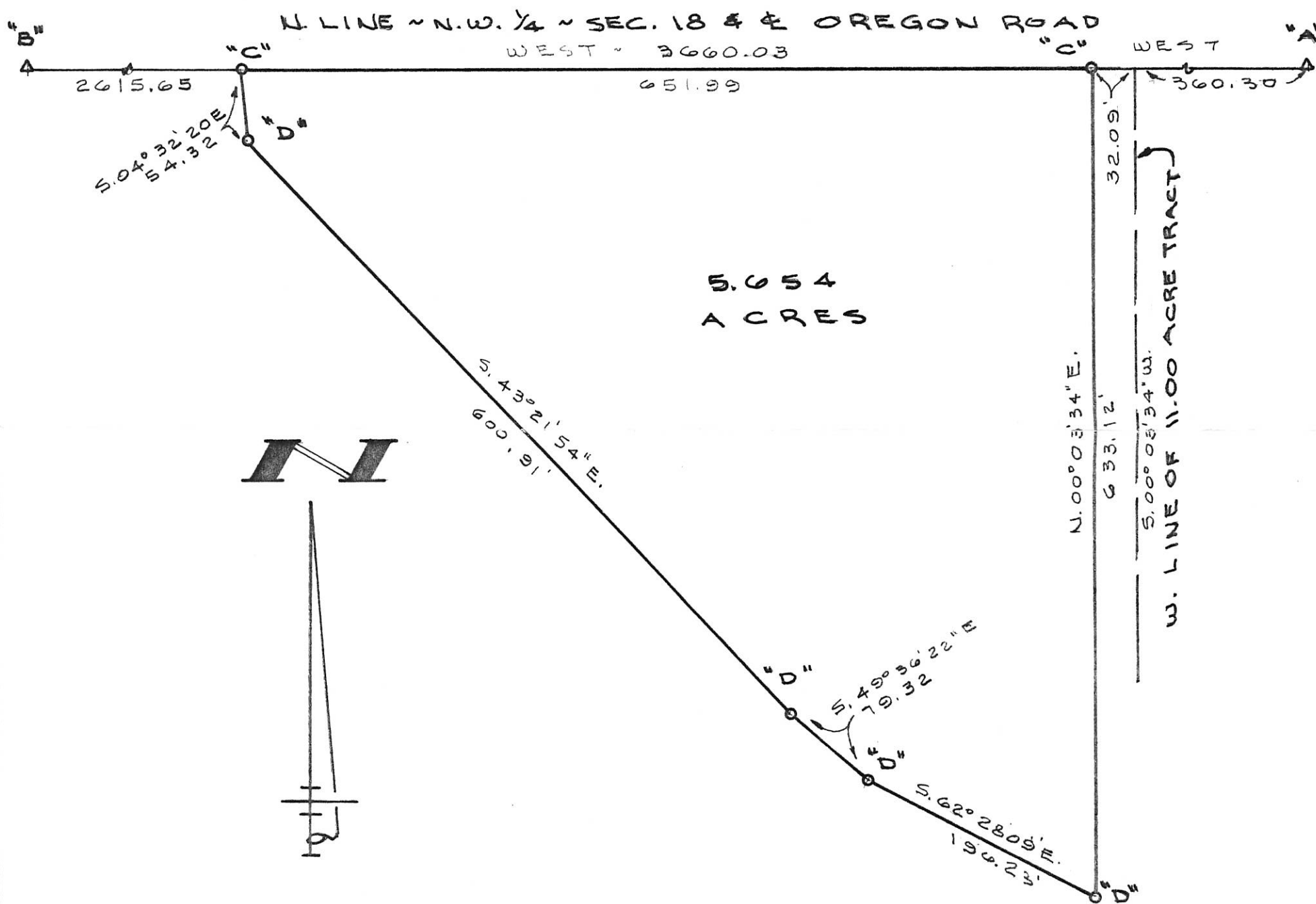

WILLRATH SURVEY
 PART OF THE N.W. 1/4 OF SECTION 18, TOWN 5 SOUTH,
 RANGE 2 EAST (HOPEWELL TWP.), MERCER COUNTY, OHIO.
 DECEMBER 15, 1993 SCALE 1" = 100'

GORDON L. GEESLIN

LAND SURVEYOR
 810 EAST MARKET STREET
 CELINA, OHIO
 PHONE (419) 586-6155



PERMANENT PARCEL No. _____

Part of: _____ Sec. _____ T _____ R _____ Township
 Grantor: _____ Area Retained: _____ Acres
 Grantee: _____ Area Transferred: _____ Acres
 Deed References: _____

APPROVALS:
 AGENCY: _____ Board of Health _____ County Sanitary Engineer _____ County Engineer

STONE # 425

LUTH SURVEY
PART NW 1/4, SEC. 18 T55, R2E
HOPEWELL TWP, MERCER CO., O.

05-18-110-004
-005
-006

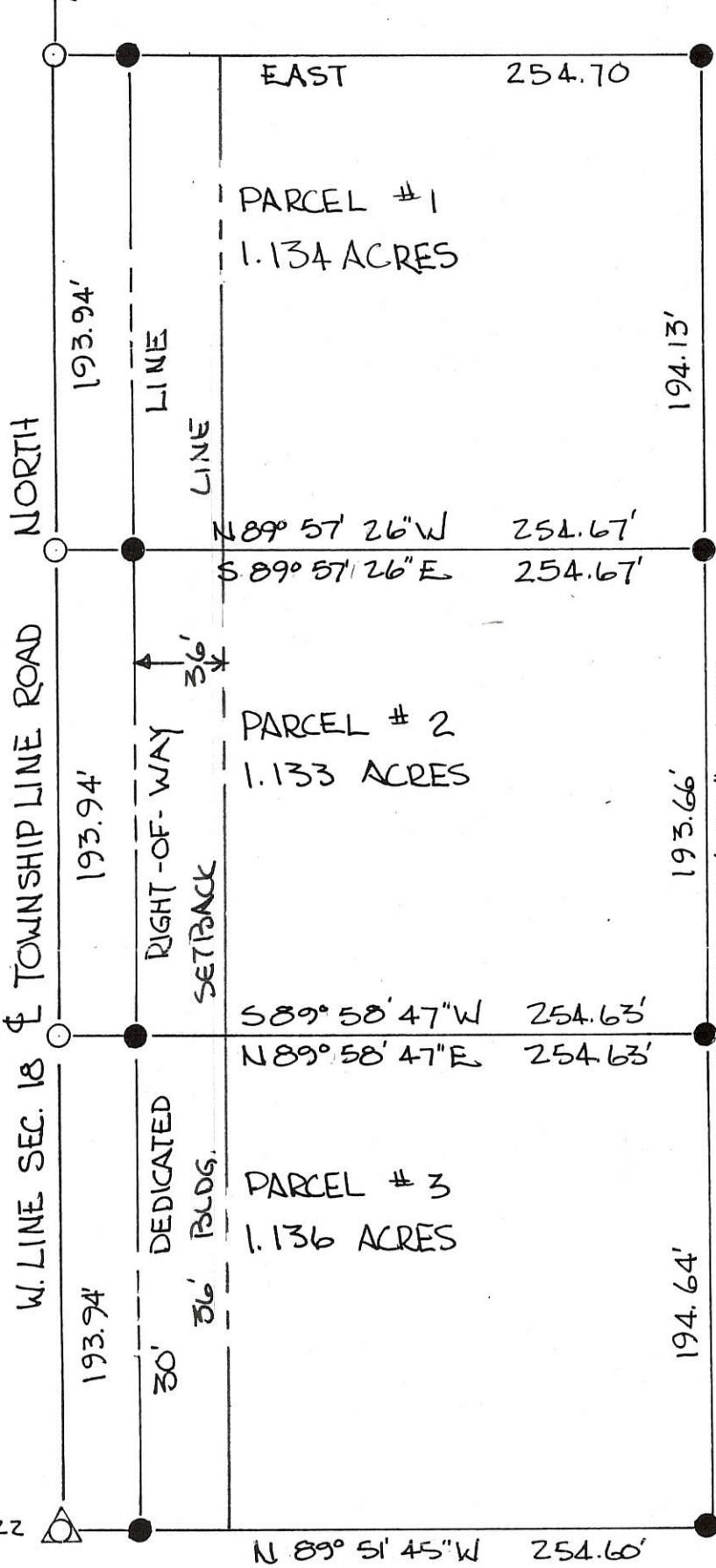

SCALE 1" = 50'

LOCATION PLAT

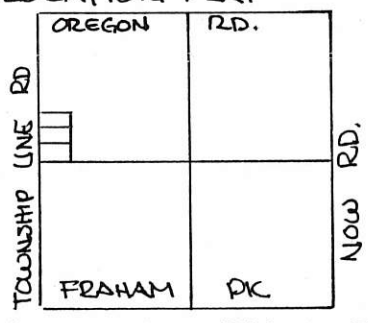

SEC. 18 - HOPEWELL TWP.

LEGEND

- 3/4" IRON PIN SET
- NAIL SET
- △ STONE REF.
- EXISTING COR. POST

THE GRANTORS DEDICATE ADDITIONAL LAND EAST OF AND ADJACENT TO THE EXISTING RIGHT OF WAY OF THE TOWNSHIP LINE ROAD TO CREATE A THIRTY (30.00) FT. RIGHT OF WAY ALONG THIS PARCEL.

Paul W. Luth 5-30-90
PAUL W. LUTH, GRANTOR DATE

Susan M. Luth 5-30-90
SUSAN M. LUTH, GRANTOR DATE

PARCEL NOT IN FLOOD HAZARD ZONE -
"FIRM" PANEL 390392-0075B

BEARINGS TURNED FROM WEST LINE OF SEC 18 - & TOWNSHIP LINE RD. ASSUMED NORTH-SOUTH -

OCCUPIED LINE

PLAT BY SURVEY MAY 1990

Roy F. Thompson, Jr.
ROY F. THOMPSON, JR.
REG. SUR # 5379

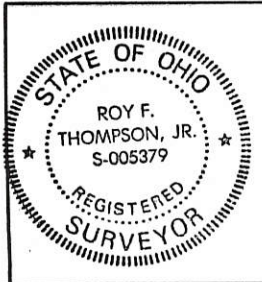

PERMANENT PARCEL No.	-----		
Part of:	NW 1/4	Sec. 18	T 55 R 2 E Hopewell Township
Grantor:	LUTH	Area Retained:	147.147 Acres
Grantee:		Area Transferred:	3.403 Acres
Deed References:	-----		
APPROVALS:	<u>Ben W. Gandy</u>	Co. Sanitary Engineer	<u>Roy F. Thompson</u>
AGENCY:	Board of Health		County Engineer
DATE:	30 MAY 90		5-30-90

Orig. Signatures

LUTH & MARTINO SURVEY
 PART NW 1/4, SEC. 18, T 55, R 2E, HOPEWELL TWP.
 MERCER CO., OHIO

05-0 ✓
 05-18-100-005

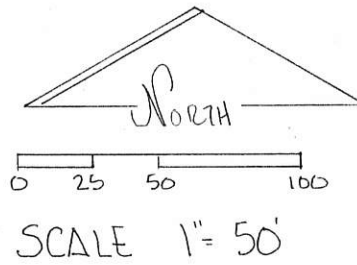
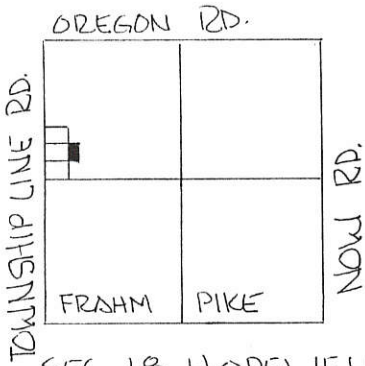

LEGEND

- △ STONE REF
- NAIL FOUND
- IRON PIN FOUND
- IRON PIN SET

SEC. 18 HOPEWELL TWP.

DEED REF. VOL 254 PGS. 353-357
 VOL. 307 PG 27

BEARING REF. W. LINE SEC 18 & TOWNSHIP LINE RD.
 ASSUMED NORTH-SOUTH-

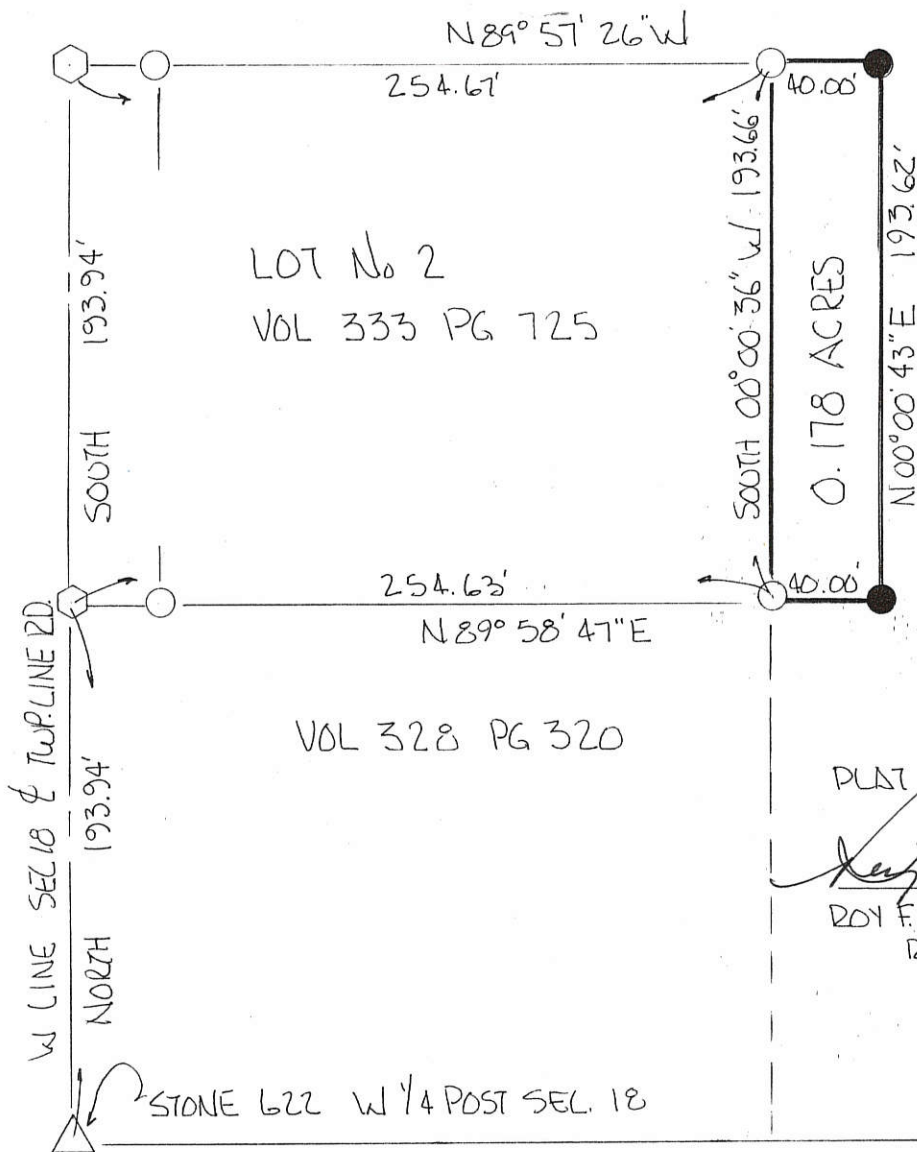

PLAT BY SURVEY SEPT 1995

Roy F. Thompson, Jr.
 ROY F. THOMPSON, JR.
 REG. SUR. # 5379



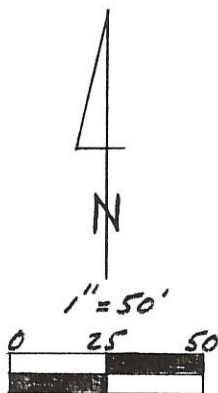
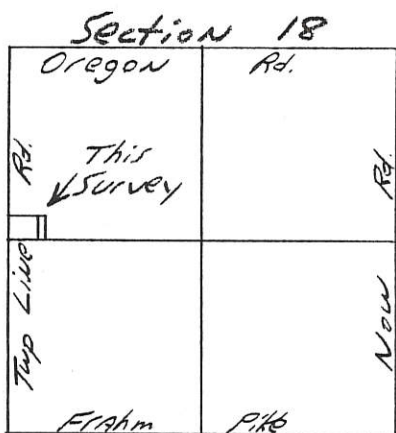

Legend:

- ▲ Stone @ NW Corner Sec. 18
- △ W¹/₄ Post Sec 18
- Existing Nail
- Existing Pin & Cap
- 5/8" x 30" Iron Pin w/cap Set

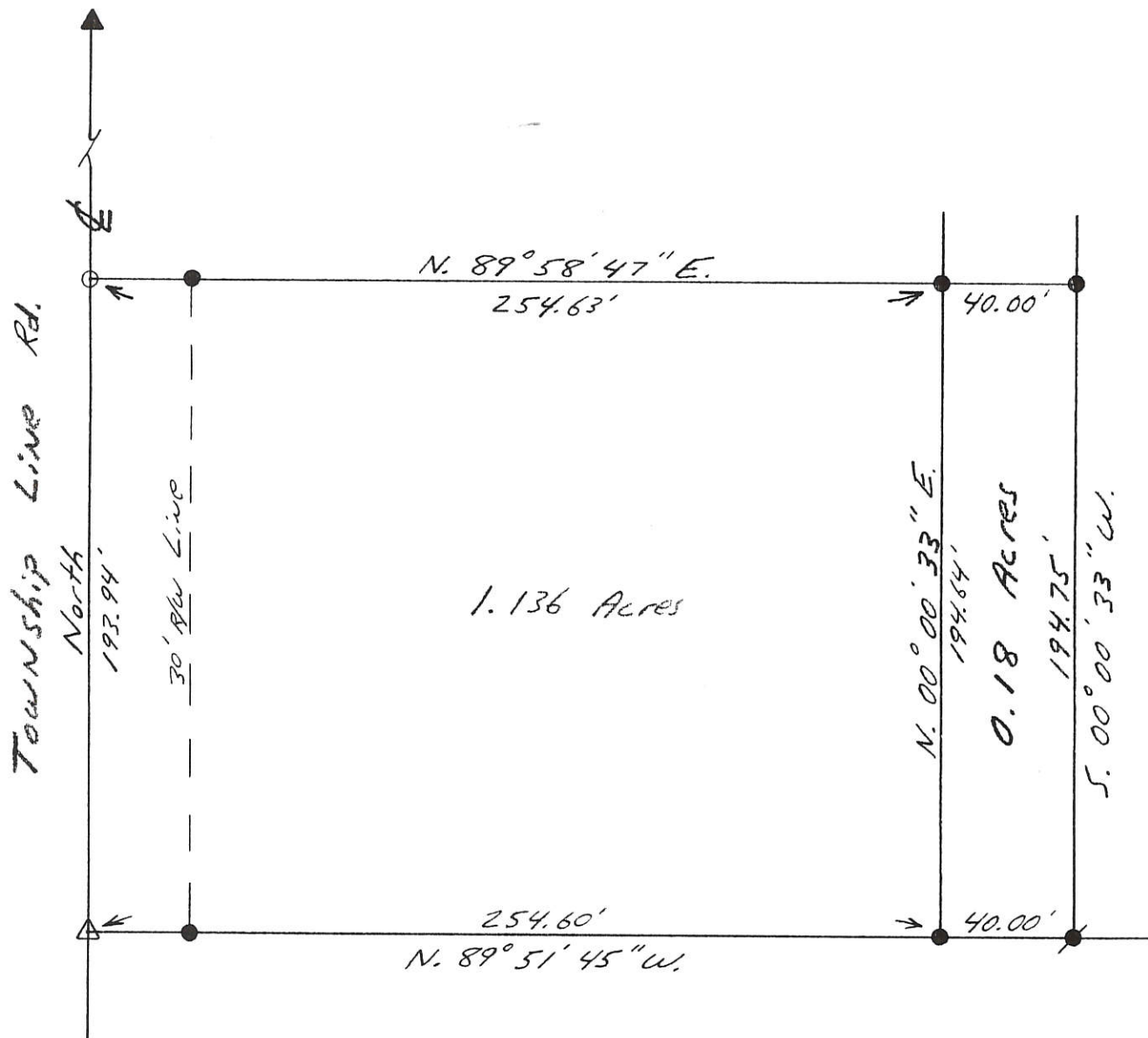

Note: Bearings used from Thompson Survey

Kent B. Marbaugh

P.S. 7421

1210 Yorkshire Court

Celina, Ohio 45822

(419) 586-4293

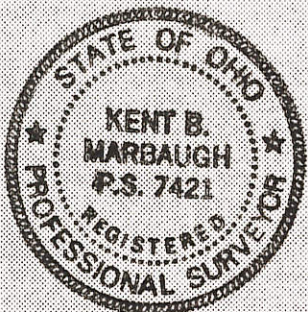

Kent Marbaugh

Luth Survey

Part of: NW¹/₄ Sec. 18 T 5S R 2E Hopewell Township

Grantor: _____ Area Retained: _____ Ac.

Grantee: _____ Area Transferred: _____ Ac.

Deed References: _____

Approvals: _____
Agency: Board of Health County Sanitary Engineer County Engineer
Date: _____

8-12-96

0518100007; 0518100008

Notes: 1. Reference is made to a survey by Jim Geeslin dated 11-7-05
 2. Reference is made to a survey by Gordon Geeslin dated 7-1982
 3. Reference is made to a prior survey by myself dated 8-12-96
 4. Reference is made to surveys by Roy Thompson dated Sept. 1995, May 1990 & Jan 1994

Note: In this surveyor's opinion, The 16' roadway called for in current deed would be an ingress and egress easement based on the wording when it was first drafted in deed volume 79, Page 630.

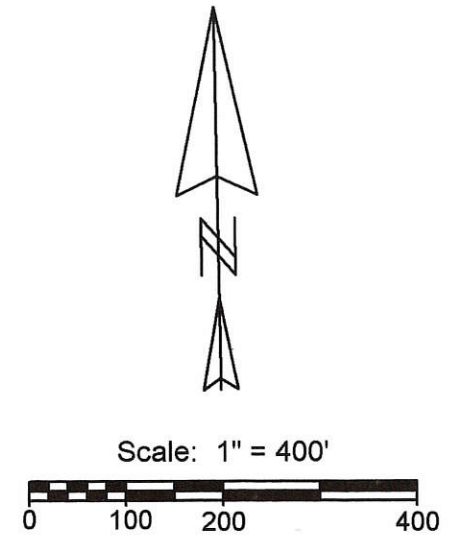

Township Line Road (40' R/W)
 (Bearing taken from the Mercer County Local Datum)

Oregon Road (50' R/W)

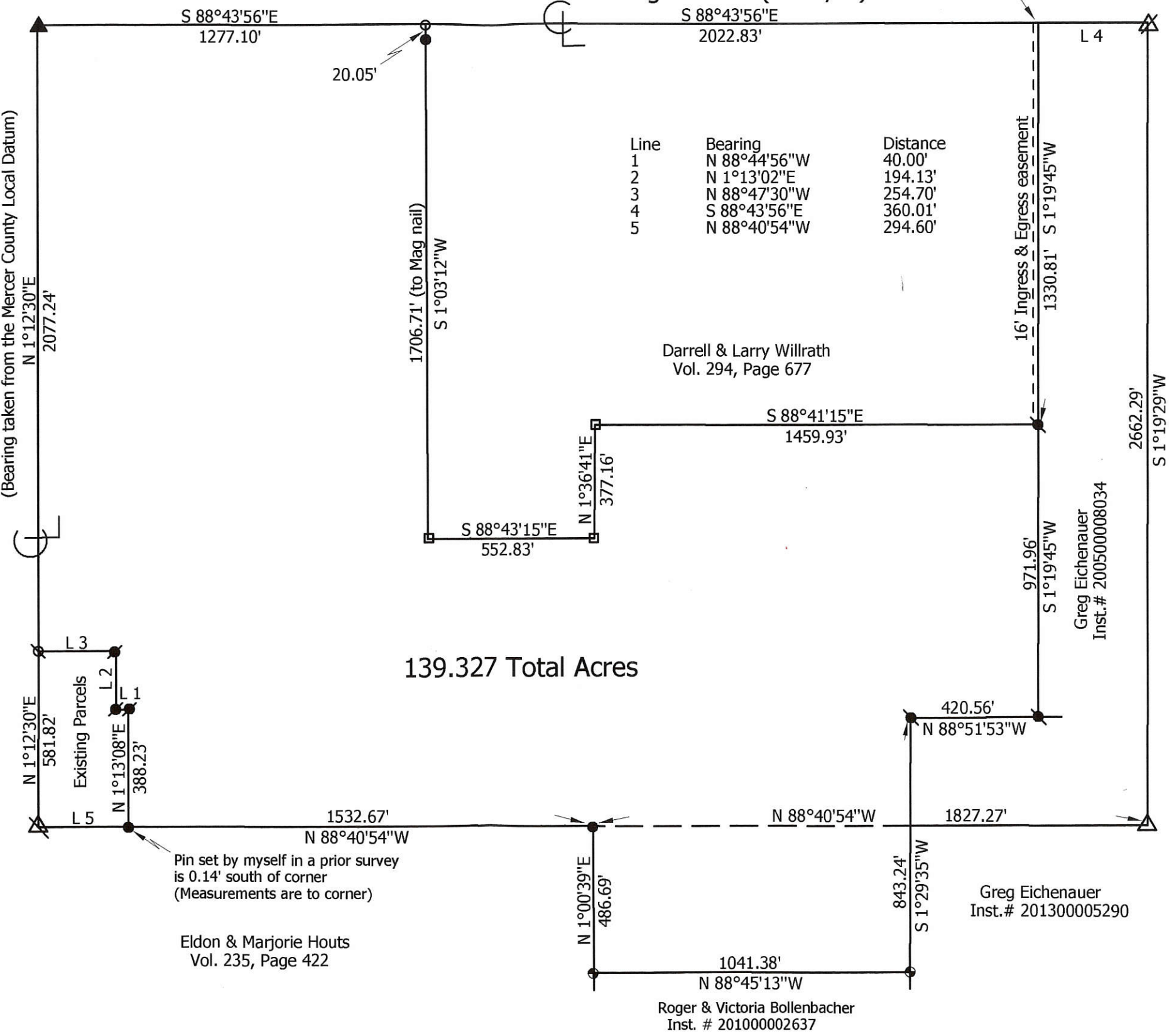

139.327 Total Acres

- Legend:**
- △ Center of section 18 (as per Roy Thompson)
 - ⊠ Cornerstone @ the W1/4 post of Section 18
 - ⊡ Cornerstone @ the N 1/4 post of Section 18
 - ▲ Cornerstone @ the NW corner of Section 18
 - Wood cornerpost
 - 5/8" X 30" Iron pin w/cap set
 - ⊙ Cornerstone Found (by Gordon Geeslin)
 - Mag nail set
 - Iron Pin found (Roy Thompson)
 - Iron Pin found (Jim Geeslin)
 - ⊙ P.K. nail found (Roy Thompson)



Marbaugh Land Surveying
 1901 Carolina Ct.
 Celina, Ohio 45822
 (419) 586-4293
Kent Marbaugh
 Kent B. Marbaugh P.S. 7421

Luth Survey

State of: Ohio County: Mercer
 Township: Hopewell Sec: 18 Town: 5S Range: 2E
 City/Village: Subdivision: Lot:
 Deed References: Vol. 307, Page 27 Date Surveyed: 9-11-13

Approvals: _____ County Engineer
 Agency: Board of Health Township Zoning Inspector
 Date: _____

Greg Eichenauer
 Inst. # 200500008034

Greg Eichenauer
 Inst. # 201300005290

Roger & Victoria Bollenbacher
 Inst. # 201000002637

Eldon & Marjorie Houts
 Vol. 235, Page 422

Pin set by myself in a prior survey is 0.14' south of corner (Measurements are to corner)

Parcel #1: 0518100008; 0518100008
0518100003

Notes: 1. Reference is made to a survey by Jim Geeslin dated 11-7-05
2. Reference is made to a survey by Gordon Geeslin dated 7-1982
3. Reference is made to surveys by myself dated 8-12-96 & 9-11-13
4. Reference is made to surveys by Roy Thompson dated Sept. 1995, May 1990 & Jan 1994

Note: In this surveyor's opinion, The 16' roadway called for in current deed would be an ingress and egress easement based on the wording when it was first drafted in deed volume 79, Page 630.

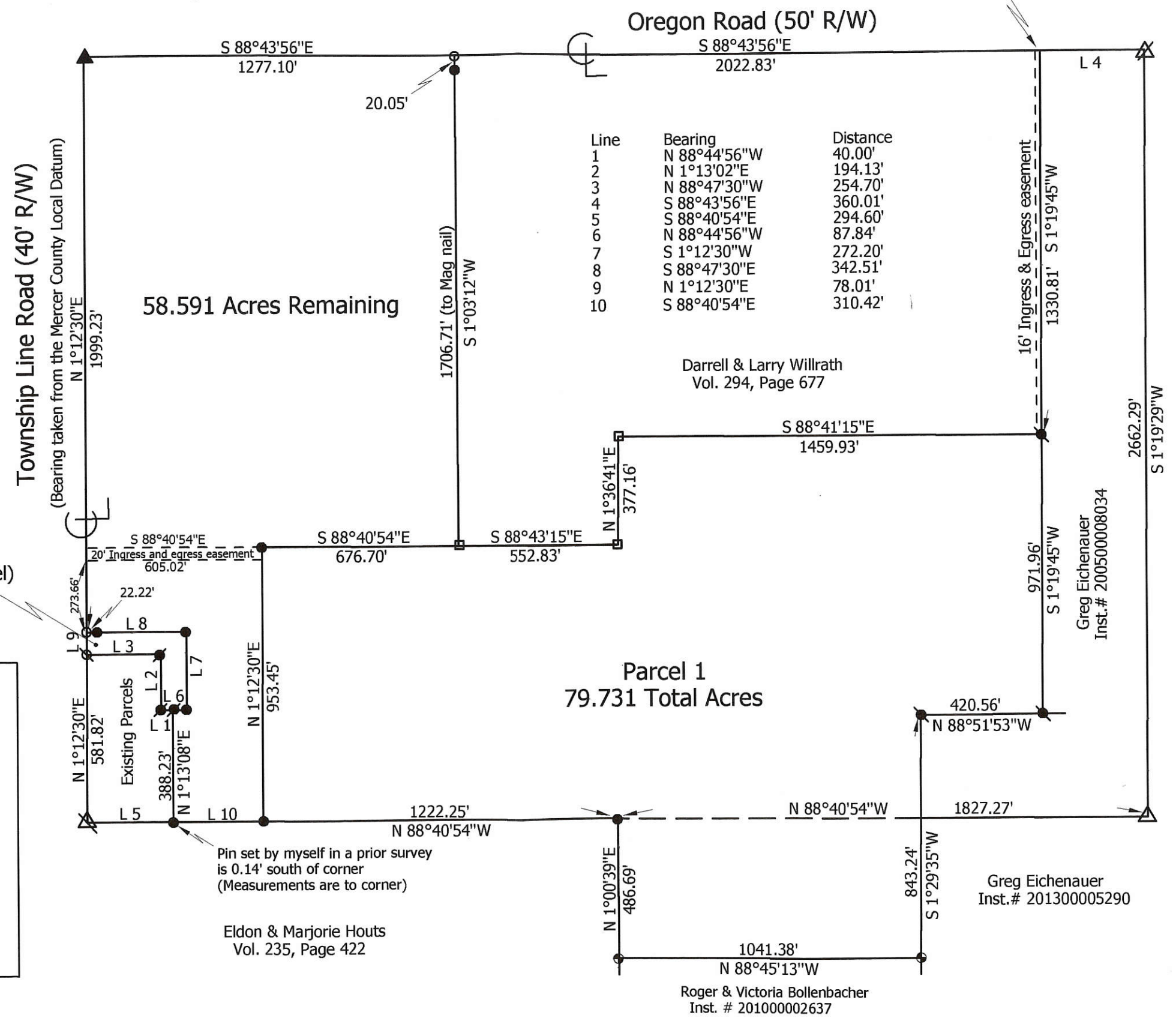
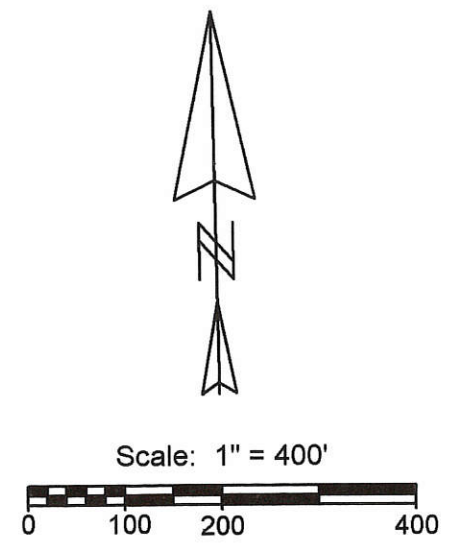

- Legend:**
- △ Center of section 18 (as per Roy Thompson)
 - ⊠ Cornerstone @ the W1/4 post of Section 18
 - ⊡ Cornerstone @ the N 1/4 post of Section 18
 - ▲ Cornerstone @ the NW corner of Section 18
 - Wood cornerpost
 - 5/8" X 30" Iron pin w/cap set
 - ⊕ Cornerstone Found (by Gordon Geeslin)
 - Mag nail set
 - Iron Pin found (Roy Thompson)
 - Iron Pin found (Jim Geeslin)
 - ⊕ P.K. nail found (Roy Thompson)

Luth Survey

State of: Ohio County: Mercer

Township: Hopewell Sec: 18 Town: 5S Range: 2E

City/Village: Subdivision: Lot:

Deed References: Inst. # 201400002621 Date Surveyed: 4-16-15

Approvals: Board of Health
Township Zoning Inspector
County Engineer

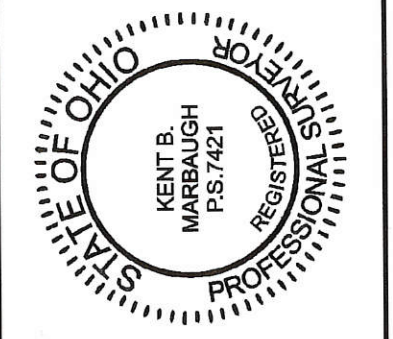

Marbaugh Land Surveying
1901 Carolina Ct.
Celina, Ohio 45822
(419) 586-4293

Kent Marbaugh
Kent B. Marbaugh P.S. 7421

05-D(18)

0518200003

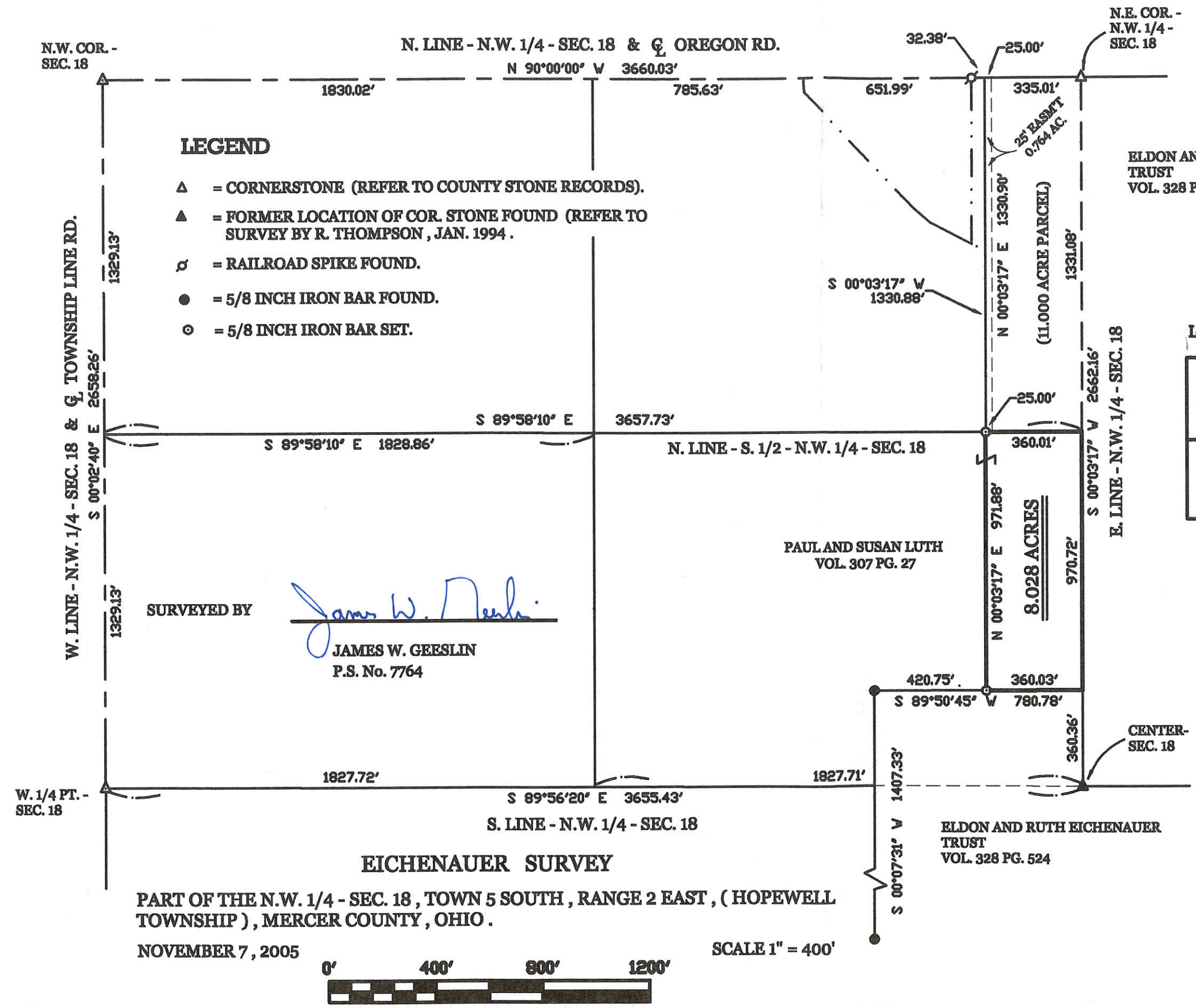

LEGEND

- △ = CORNERSTONE (REFER TO COUNTY STONE RECORDS).
- ▲ = FORMER LOCATION OF COR. STONE FOUND (REFER TO SURVEY BY R. THOMPSON, JAN. 1994).
- ⊕ = RAILROAD SPIKE FOUND.
- = 5/8 INCH IRON BAR FOUND.
- ⊙ = 5/8 INCH IRON BAR SET.

LOCATION SKETCH

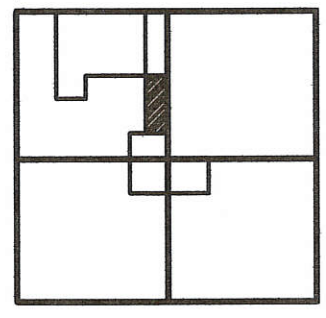

SECTION 18

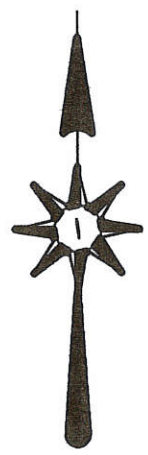

EICHENAUER SURVEY
PART OF THE N.W. 1/4 - SEC. 18, TOWN 5 SOUTH, RANGE 2 EAST, (HOPEWELL TOWNSHIP), MERCER COUNTY, OHIO.

NOVEMBER 7, 2005



SCALE 1" = 400'

PERMANENT PARCEL No. _____

Part of: _____ Sec. _____ T. _____ R. _____

Grantor: _____ Area Retained: _____ Acres

Grantee: _____ Area Transferred: _____ Acres

Deed References: _____

APPROVALS:
AGENCY: _____
DATE: _____

Board of Health

Township Zoning Officer

County Engineer

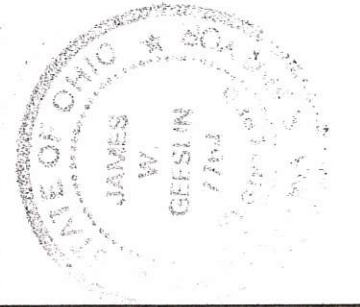

GEESLIN
LAND SURVEYING

P.O. BOX 422
CELINA, OHIO

PHONE (419) 586-6155
FAX (419) 678-9332

05-D ✓

OWNER :
TIM HANNA
 4.000 ACRES BY DEED
 VOL. 321 PG. 551

LOCATION SKETCH

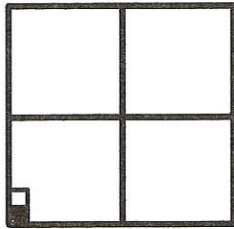

SECTION 18

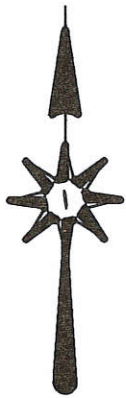

W. 1/4 PT. -
 SEC. 18

SURVEYED BY

James W. Geeslin
JAMES W. GEESLIN
 P.S. No. 7764

HOWELL
 O.R. 17 PG. 273
 5.000 ACRES

LEGEND

- △ = CORNERSTONE (REFER TO CO. STONE REC'S).
- ⊙ = IRON PIPE FOUND.
- ⊘ = MAG NAIL SET.
- ⊙ = 5/8 INCH IRON BAR SET.

C.B. = CATCH BASIN.
 C.O. = CLEAN OUT.

HANNA SURVEY

PART OF THE SOUTHWEST QUARTER
 OF SEC. 18, TOWN 5 SOUTH, RANGE 2
 EAST, (HOPEWELL TOWNSHIP),
 MERCER COUNTY, OHIO.

FEBRUARY 22, 2006 SCALE 1" = 100'



HOUTS
 VOL. 235 PG. 422
 75.00 ACRES BY DEED

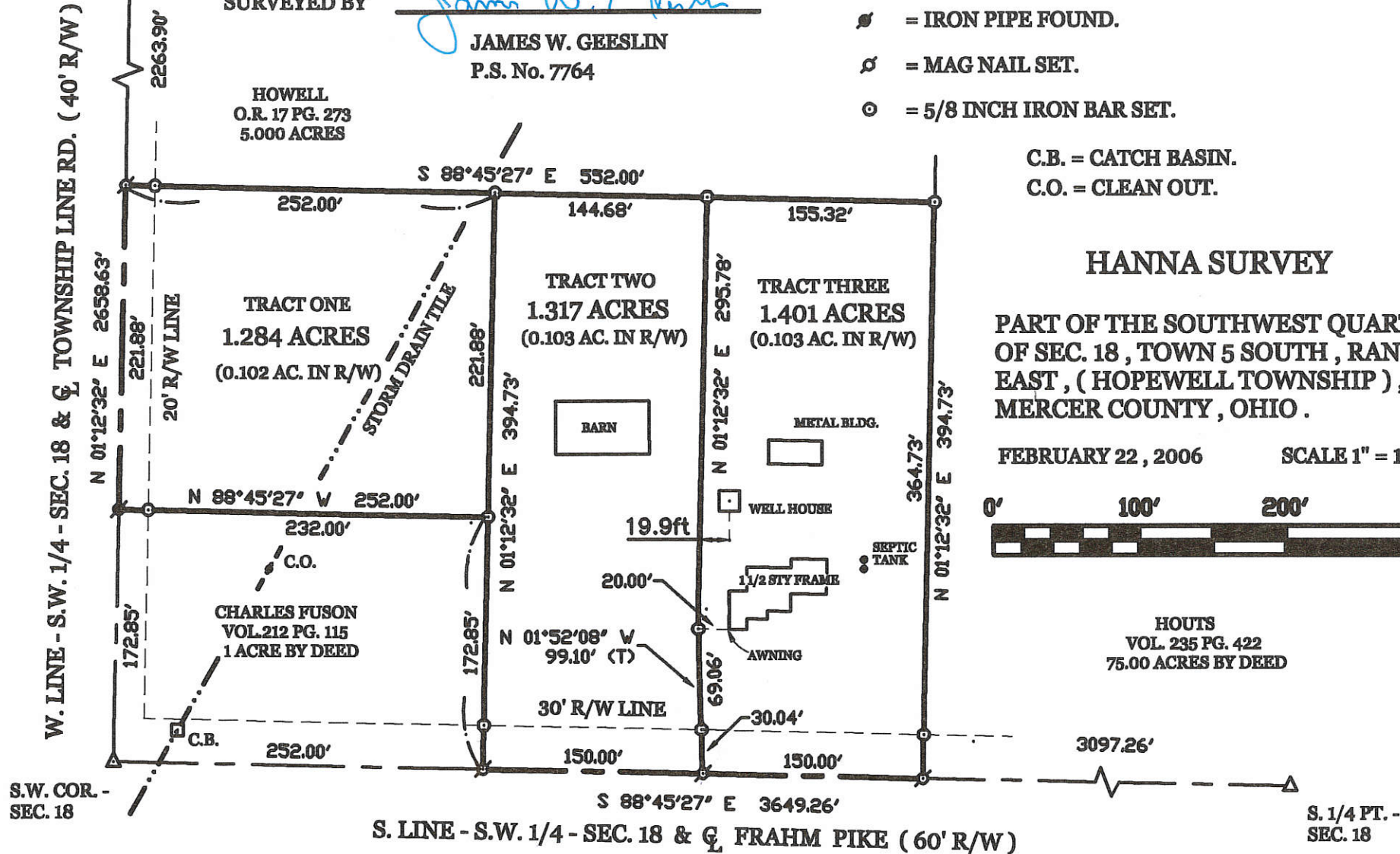

* PROPOSED SEPTIC SYSTEMS FOR TRACTS ONE AND TWO ARE TO
 OUTLET INTO THE STORM DRAIN TILE SHOWN.

PERMANENT PARCEL No. _____	Part of _____ Sec. _____ T. _____ R. _____ Township _____
	Greater _____ Area Retained _____ Acres Greater _____ Area Retained _____ Acres
Deed References _____	
APPROVALS AGENCY: _____ Date: _____	Board of Health _____ Date: _____ Township Zoning Officer _____ Date: _____ County Engineer _____ Date: _____

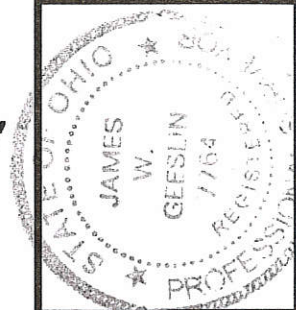

GEESLIN
LAND SURVEYING
 P.O. BOX 422
 CELINA, OHIO 45822
 PHONE: (419) 586-6155
 FAX: (419) 678-9332

05-18-300-006
 -012
 05-D
 2/19/06

WILSON SURVEY
 PART SW FRACTIONAL 1/4, SEC. 18, T55, R2E
 HOPEWELL TWP., MERCER CO., OHIO

Co Engr. ✓
 05-D
 05-18-300-007

LOCATION PLAT

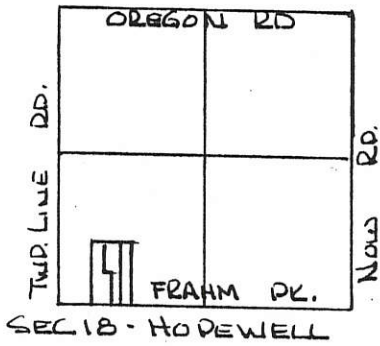

SCALE 1" = 50'

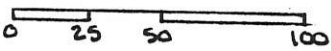

LEGEND

- PIN FOUND ○
- PIN SET ●
- SPIKE FOUND ◊
- SPIKE SET ◐
- STONE REF. ▲

PARCELS NOT IN FLOOD HAZARD ZONE.
 "FIRM" PANEL No. 390392-OUTSB
 SEPT 1989 -

WILSON (GEORGE) VOL 287 PG. 20

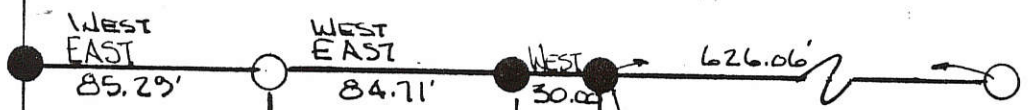

TRACT No. 3 1.412 AC.

TRACT No. 2 0.819 AC.

TRACT No. 1 0.395 AC.

HOBBS VOL. 235 PG 422

WILSON VOL. 287 PG. 20 (GEORGE)

WILSON (ROGER) VOL 287 PG 26

S 00° 09' 01" W 574.00'

N 00° 09' 01" E 374.00'

N 00° 09' 01" W 574.00'

S 00° 09' 01" W 574.00'

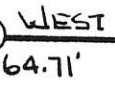

PLAT BY SURVEY

Roy F. Thompson Sr.
 ROY F. THOMPSON SR.
 REG. SUR. #5319
 AUGUST, 1993-

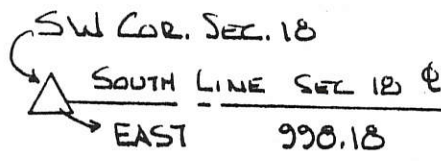

FRAHM PIKE



EXISTING R/W LINE

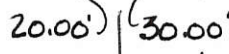

TRACT No. 2 to be COMBINED WITH TRACT No. 3 RESULTING PARCEL TO BE 2.240 ACRES.

TRACT No. 1 TO BE ACCESS TO RESIDUE OF LANDS DESC. VOL 287 PG 20.

PERMANENT PARCEL No. _____		
Part of:	SW 1/4 Sec. 18 T55 R2E Hopewell Township	
Grantor:	Wilson Area Retained: 28.786 Acres	
Grantee:	Wilson Area Transferred: 1.214 Acres	
Deed References:	Vol 287 P 26	
APPROVALS:		
AGENCY:	Board of Health	Co. Sanitary Engineer
DATE:		County Engineer

#1: 0518300013 ; #2: 0518300008 ; #3: 0518300010

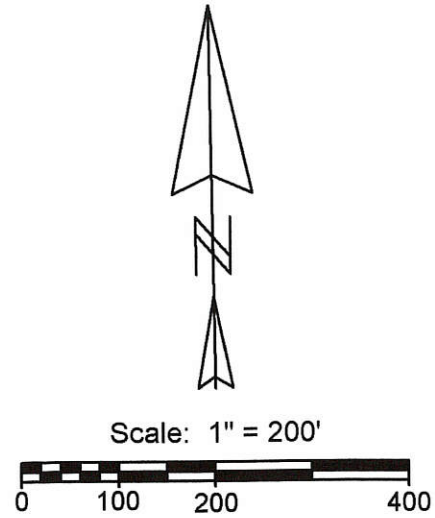
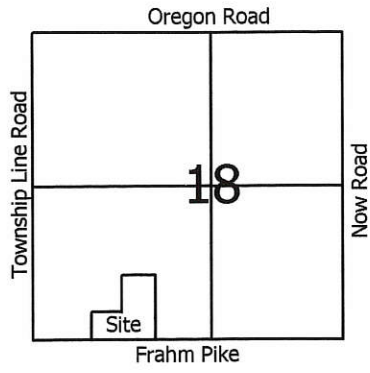

- Legend:**
- ▲ Cornerstone @ the S1/4 post of Section 18
 - △ Cornerstone @ the SW corner of Section 18
 - ⊙ 5/8" X 30" Iron pin w/cap set
 - Iron pin found
 - Railroad spike found
 - ⊙ Iron pin found 30.0' from corner

Line	Bearing	Distance
1	S 88°45'19"E	16.97'
2	S 88°46'58"E	50.00'
3	N 1°18'51"E	50.00'
4	N 88°45'27"W	150.00'
5	N 88°45'27"W	30.00'
6	N 88°45'27"W	150.00'

Notes:
 1. Reference is made to a survey by Gordon Geeslin dated July 1982
 2. Reference is made to surveys by Roy Thompson dated Aug. & Sept. 1993

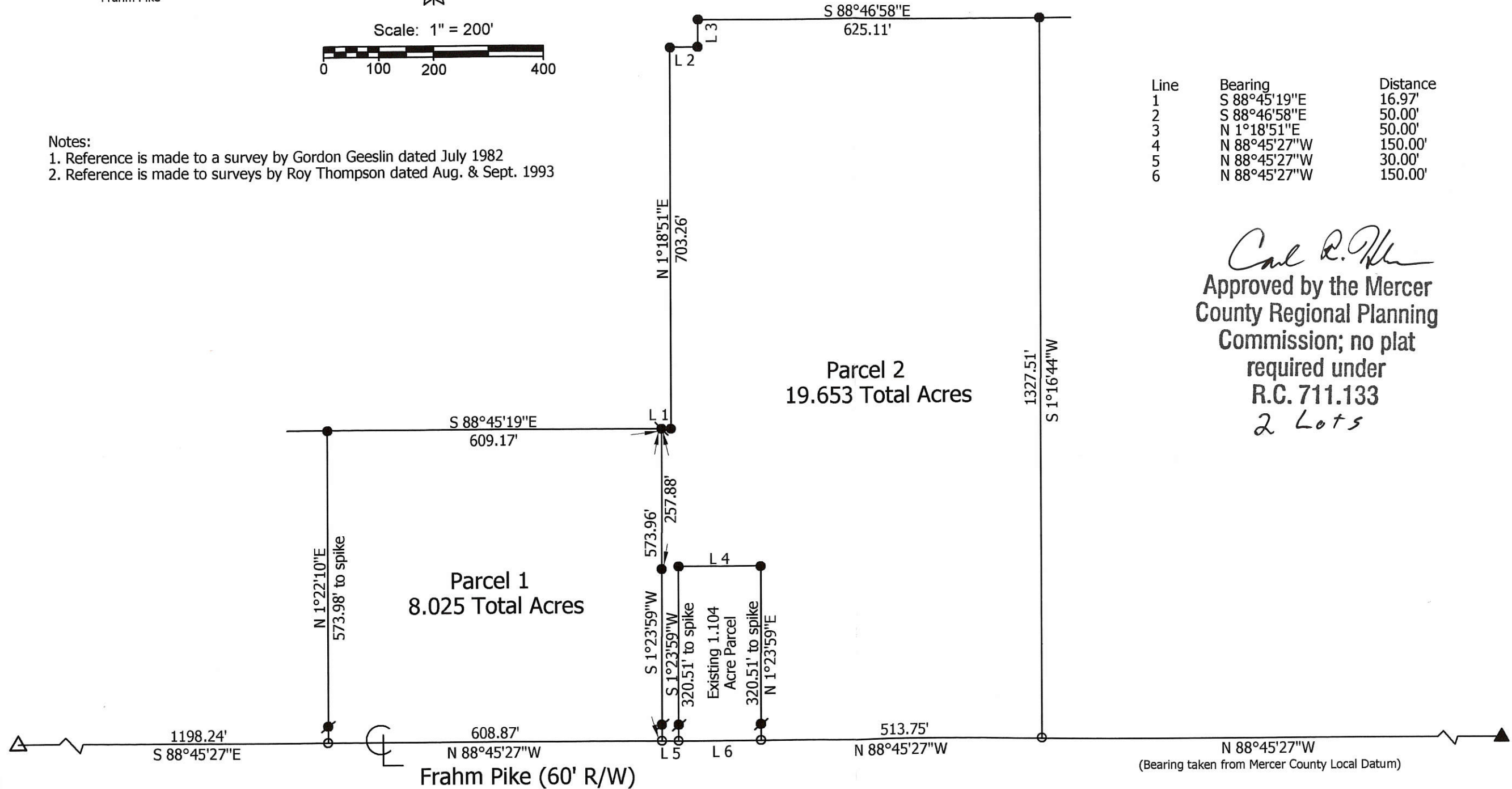

Carl R. Miller
 Approved by the Mercer
 County Regional Planning
 Commission; no plat
 required under
 R.C. 711.133
 2 Lots



**Marbaugh
 Land Surveying**
 1901 Carolina Court
 Celina, Ohio 45822
 (419) 586-4293
Kent B. Marbaugh
 Kent B. Marbaugh P.S. 7421

Wilson Survey

State of: Ohio County: Mercer
 Township: Hopewell Sec: 18 Town: 5S Range: 2E
 City/Village: _____ Subdivision: _____ Lot: _____
 Deed References: Vol. 287, Page 26 Date Surveyed: 6-30-09
 Approvals: *Carl R. Miller* County Engineer
 Agency: *Robert J. ...* Township Zoning Inspector
 Date: 7-13-09

05-D(18)

WILSON SURVEY
 PART SW 1/4, SEC. 18, T55, R2E, HOPEWELL TWP.
 MERCER CO., OHIO

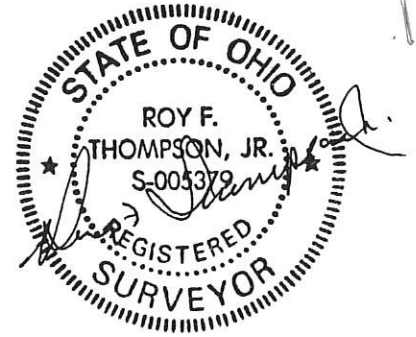

LEGEND

- △ STONE COR.
- ◻ SPIKE FND.
- IRON PIN FND.



NO SCALE

PLAT BY SURVEY SEPT 1993

Roy F. Thompson Jr.

ROY F. THOMPSON JR. REG. SUR. # 5379

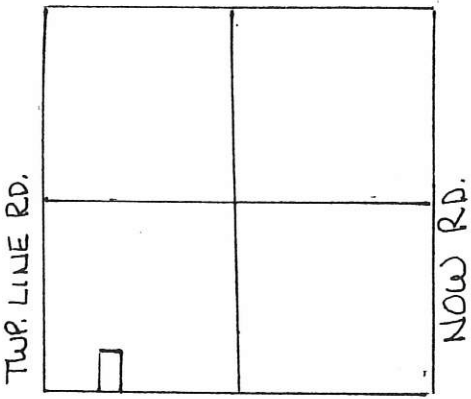

SEC 18 HOPEWELL TWP.

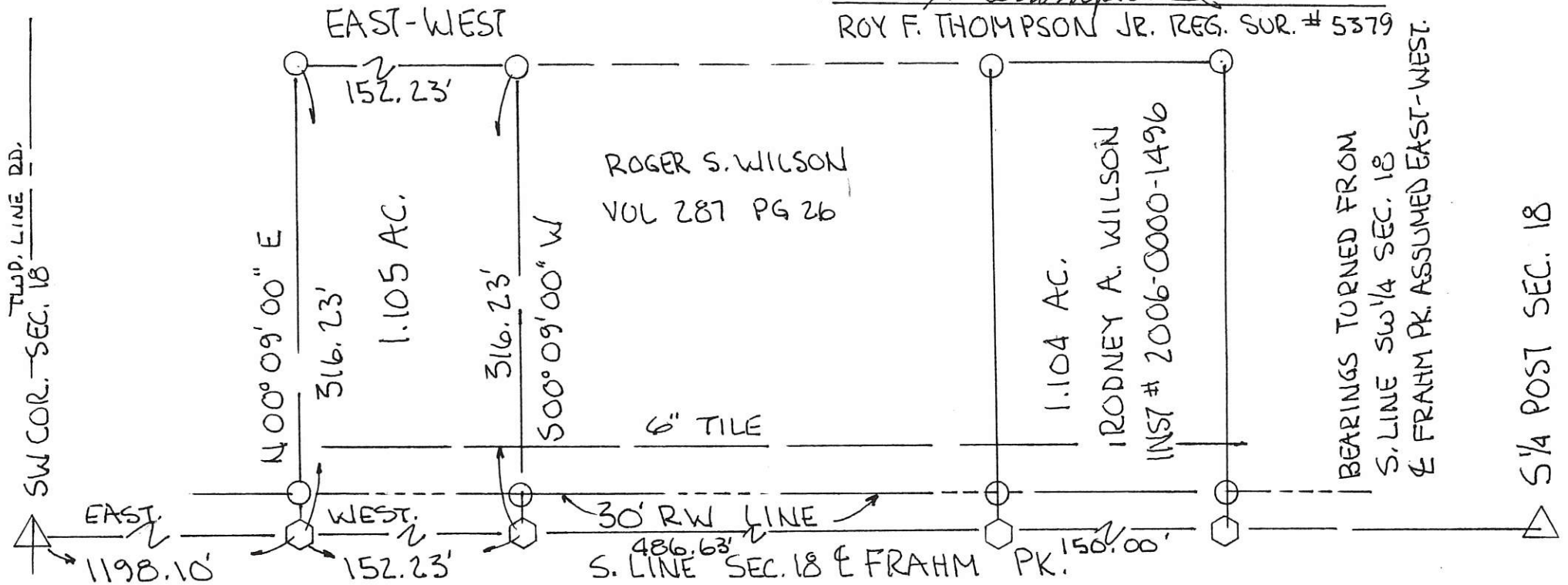

HOPEWELL TWP. ZONING INSP.

Todd Thomas 4/8/06

TODD THOMAS ZONING INSP. DATE

MERCER CO. HEALTH DEPT.

Chris Miller 6-9-06

CHRIS MILLER DEP. SANITARIAN

MERCER CO. ENGR

James A. Wiechart

JAMES WIECHART PE. P.S. DATE

0518 300 013

05-D

05-18-300-010

010



County

WILSON SURVEY

PART SW 1/4, SEC 18, T5S, R2E, HOPEWELL TWP., MERCER CO., OHIO

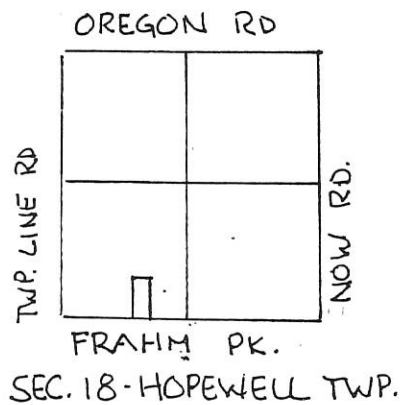

DEED REF. VOL 287 PG. 26

SCALE 1" = 60'

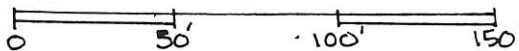

EAST 150.00'

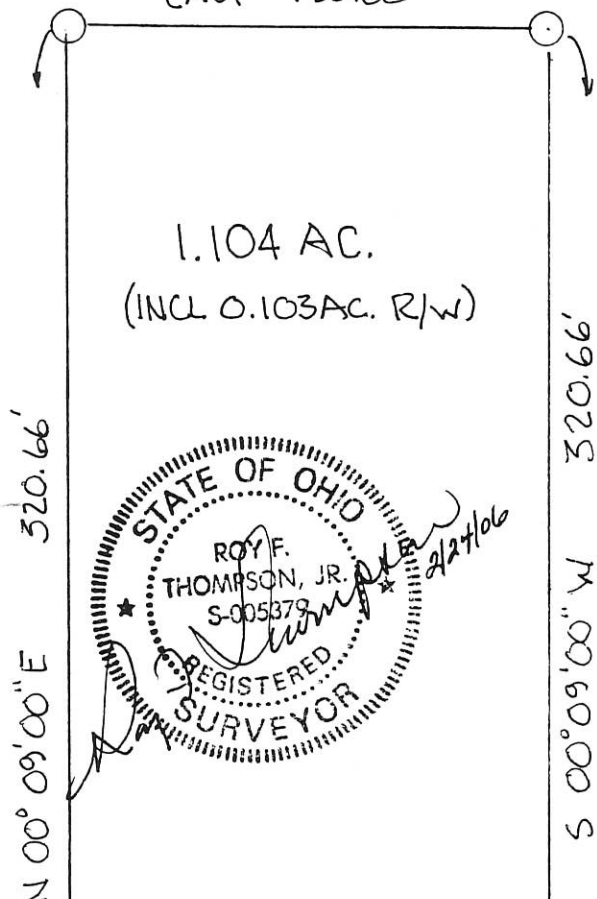

1.104 AC.
(INCL 0.103 AC. R/W)

BEARINGS TURNED FROM SOUTH
LINE SEC. 18 ASSUMED EAST-WEST.

PLAT BY SURVEY SEPT 1993

Roy F. Thompson, Jr.
 ROY F. THOMPSON, JR. REG. SUR. #5379

APPROVED:

HOPEWELL TWP ZONING INSP.

Todd Thomas
 TODD THOMAS, ZONING INSP.

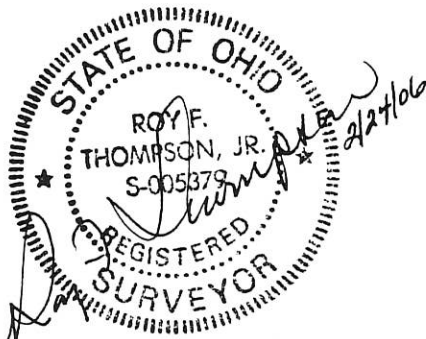

SW COR SEC. 18

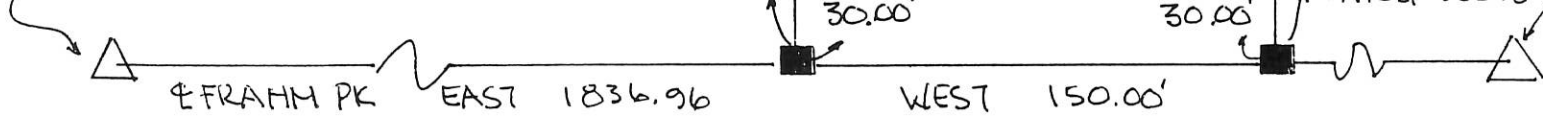

APPROVALS:

MERCER COUNTY HEALTH DEPT.

MERCER COUNTY ENGINEER

JAMES WIECHART, P.E.

05-D
05-18-300-010 ✓

KARCH SURVEY

Part of the S.E. 1/4 of SE 1/4 Sec. 18, T 5 S, R 2 E
Hopewell Twp., Mercer County, Ohio

Location Map

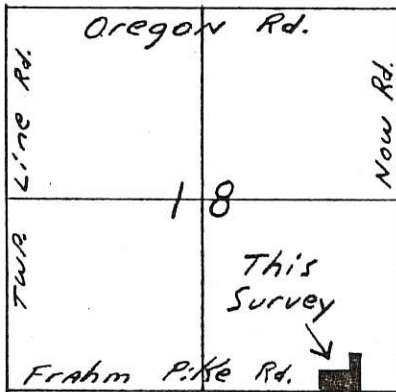

Scale: 1" = 50'



Legend

- Iron Pin Set
- ⊗ Railroad Spike Set

Owners:
 Donald & Ruth Karch
 Vol. 188 Pg. 475
 Vol. 309 Pg. 922

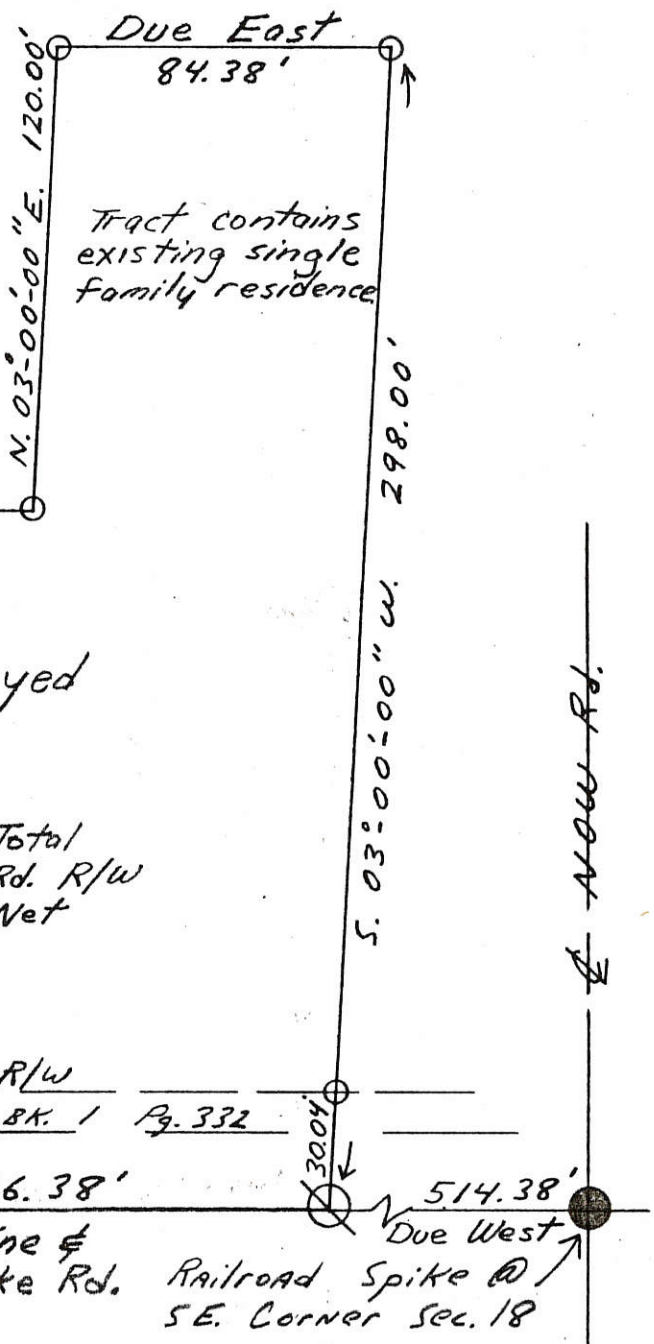

Area Surveyed
1.156 Ac.

1.156 Ac. Total
 0.156 Ac. Rd. R/W
 1.000 Ac. Net

30.00' Dedicated R/W
 20.00' Existing R/W Rd. BK. 1 Pg. 332
 Due West 226.38'
 Due West 514.38'
 Stone @ S 1/4 Post Sec. 18
 Railroad Spike @ SE Corner Sec. 18

Parcel not in Flood Hazard Zone Parcel # 390392 0075 B
 Frahm Pike Assumed to Bear AN East, West direction

Alvin J. Spraley
 Alvin J. Spraley
 Registered Surveyor
 No. 5016
 Field Work by:
 Kent Marbaugh, S.I.T.
 Steven Kremer, S.I.T.

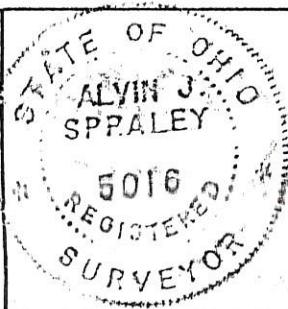

PERMANENT PARCEL No. _____	
Part of: SE 1/4 Sec. 18 T 5 S R 2 E Hopewell Township	
Grantor: Karch	Area Retained: 38.84 ± Acres
Grantee: Karch	Area Transferred: 1.156 ± Acres
Deed References: _____	
APPROVALS: <i>Ben W. Cady</i>	NA
AGENCY: Board of Health	Co. Sanitary Engineer
DATE: 23 Sep 91	<i>John F. Williams</i> County Engineer 9-23-91

05-18-30-004
-000

05-9

1" = 100'



N. 89°-30' E.
552.00'

9.00 Ac.

N. 0°-29' W.
616.60'

789.45'
S. 0°-29' E.

S. 89°-30' W.
252.00'

172.85'
N. 0°-29' W.

S. 89°-30' W.
300.00'

El Fahm
Pike

C. Fuson
1.00 Ac.

89°-59'

SW
Corner
Sec. 18

Twp. Line Road

BOLLENBACHER SURVEY
HOPEWELL TOWNSHIP
SECTION 18, TOWN 5S, RANGE 2E
MERCER COUNTY, OHIO

Bk. #4, Page 194

February 4, 1969

Surveyed by:

Donald J. Jarvis



Registered Surveyor 5258

John Bollenbacher et ux
75 Ac.

05-18-300-003
400-001
-002
-003
-004

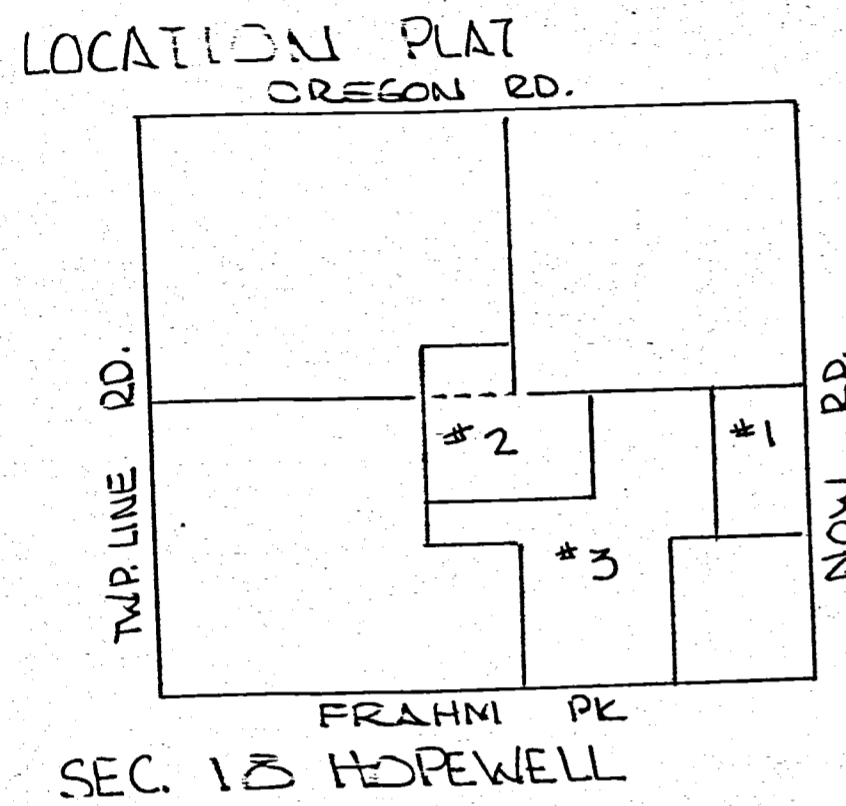
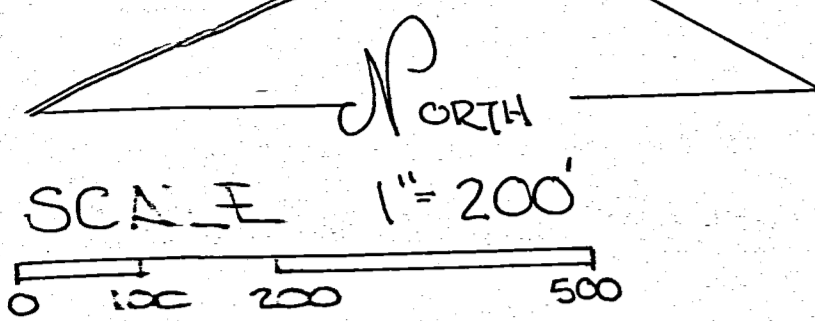

- LEGEND
- △ STONE REF.
 - IRON PIN SET
 - ⊕ SPIKE SET

BEARINGS TURNED FROM SOUTH LINE SECTION 18
& FRAHM PIKE ASSUMED EAST-WEST-

PLAT BY SURVEY JAN. 1994

Roy F. Thompson, Jr.
ROY F. THOMPSON, JR. REG. SUR. # 5379.

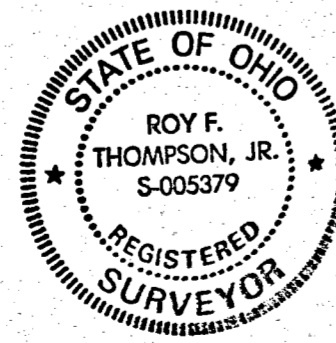

SLABAUGH SURVEY
W 1/2 SE 1/4, NE 1/4 SE 1/4, PART NE 1/4 SW 1/4, PART SE 1/4 NW 1/4,
SECTION 18, TOWN 5 SOUTH, RANGE 2 EAST,
HOPEWELL TOWNSHIP, MERCER COUNTY, OHIO

DEED REF. VOL. 137, PG. 270

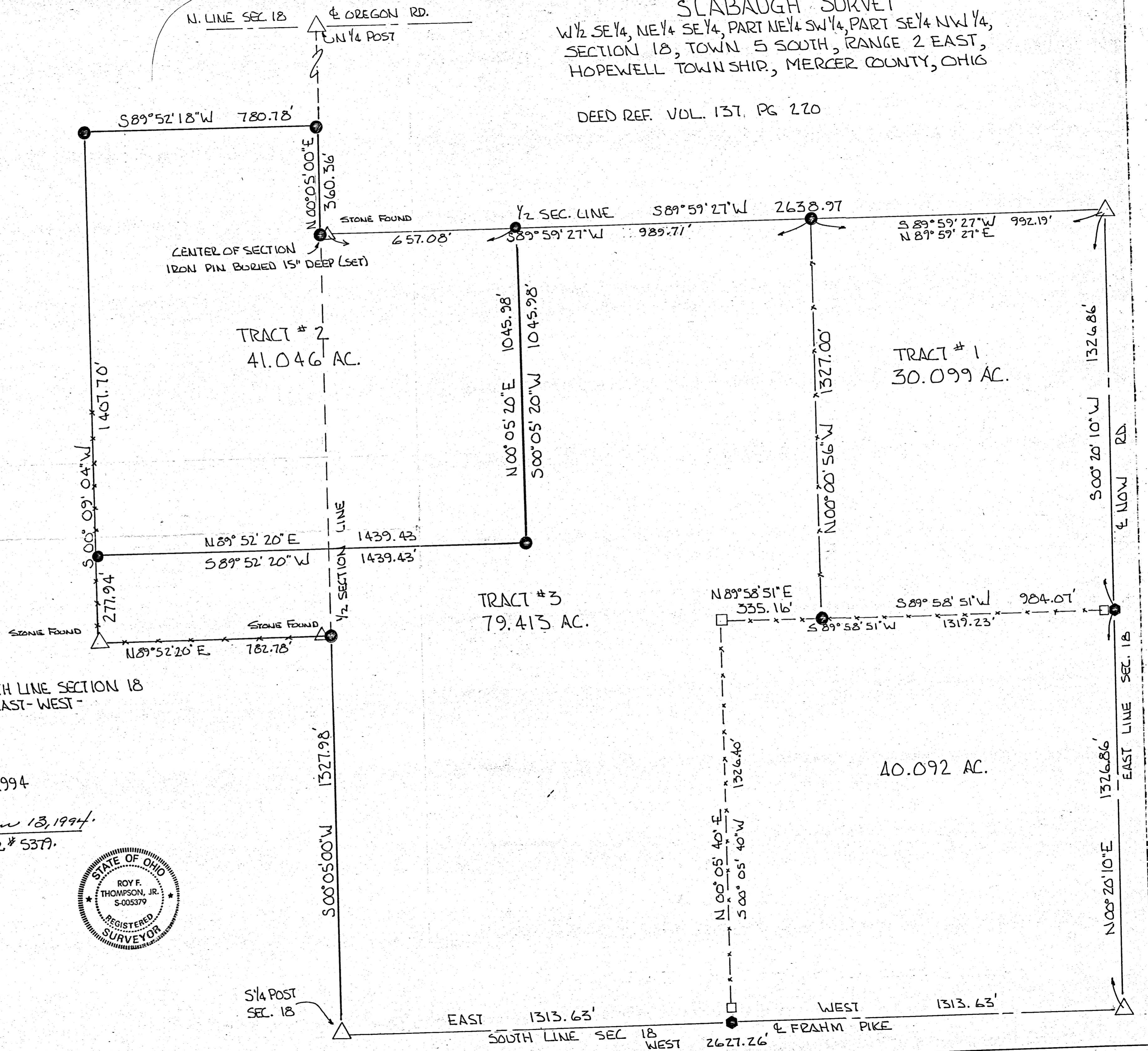

05-18-300-002
-007
-008
-009

WILSON SURVEY - PART OF THE S.W.
1/4 OF SECTION 18, TOWN 5 SOUTH, RANGE
2 EAST (HOPEWELL TWP.), MERCER CO., OHIO.
JULY, 1982 SCALE 1" = 100'

SURVEYED BY Gordon L. Geeslin
GORDON L. GEESLIN
REGISTERED SURVEYOR
No. 5372
540 E. MARKET STREET
CELINA, OHIO 45822

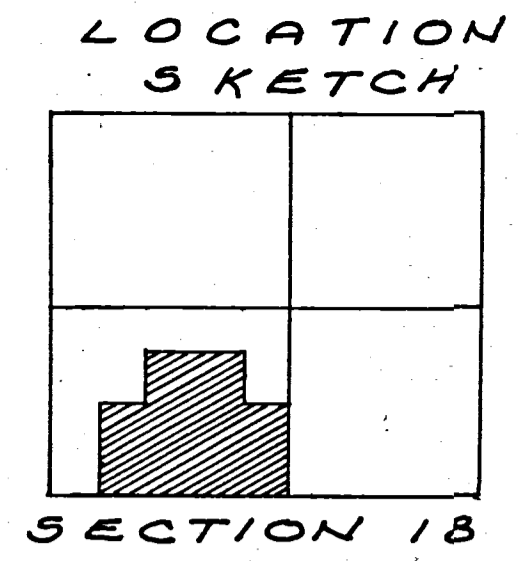
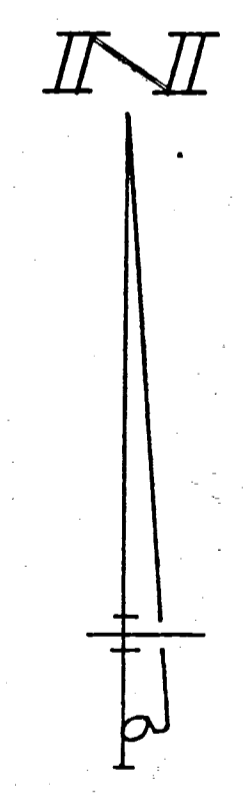
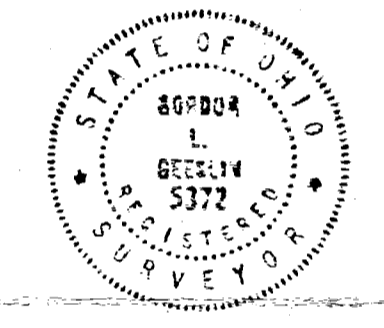

LEGEND

- "A" = CORNER STONE @ S. 1/4 POST - SEC. 18. BELIEVED TO HAVE BEEN SET BY MARCUS SCHUYLER IN 1841; ALSO FD. TILE WITH WOOD STAKE 1.5" WEST OF STONE. BELIEVED TO HAVE BEEN SET BY D. SMALLEY IN 1912. (SEE SURVEY BOOK 1, PAGE 90.)
- "B" = STONE @ S.W. COR. - SEC. 18. (SEE COUNTY STONE REFERENCES)
- "C" = RAILROAD SPIKE @ S.E. COR. - SEC. 18 (SEE COUNTY STONE REFERENCES)
- "D" = STONE, FD. BELIEVED TO HAVE BEEN SET BY A.W. FISHBAUGH IN 1919. (SEE SURVEY BOOK 2, PAGE 270.)
- "E" = STONE, FD. (SEE SURVEY BOOK 1, PAGE 90.)
- "F" = RAILROAD SPIKE SET.
- "G" = 3/8" x 30" IRON BAR SET.

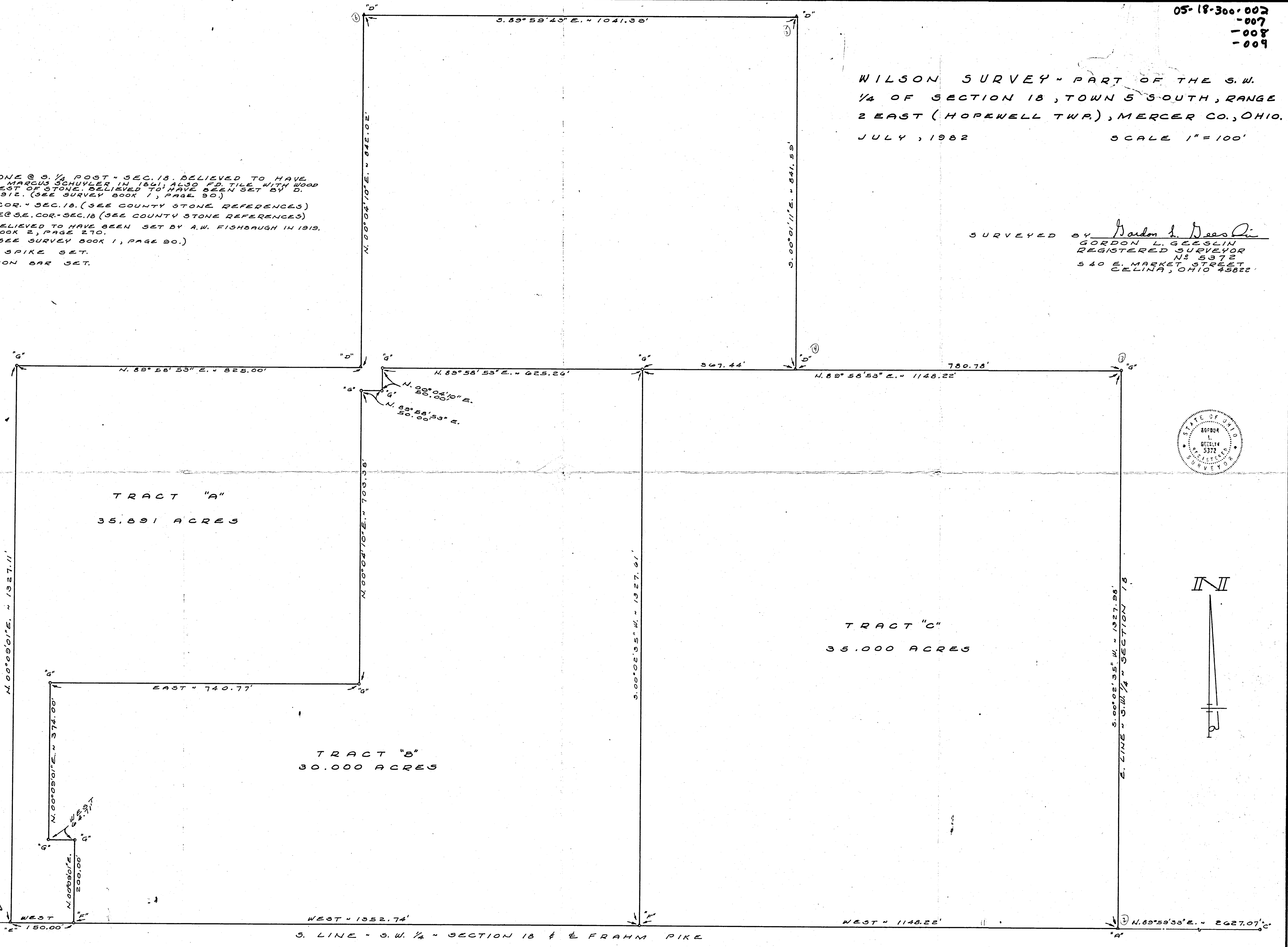

TRACT "A"
35.891 ACRES

TRACT "C"
35.000 ACRES

TRACT "B"
30.000 ACRES

S. LINE - S.W. 1/4 - SECTION 18 & E FRAHM PIKE

194 05-D

199

SURVEY No. _____ In Town 55 of Range 2 East. Plat and Notes of Survey made by me on the _____ day of Feb, A. D. 1969, in Sec. 18, Town 55, of Range 2E, at the instance of Bollenbacher Surveyor - Tevis # 5258

The Johnson-Watson Co., Dayton, Ohio - N-7609

BK 4 HOPEWELL TWP.

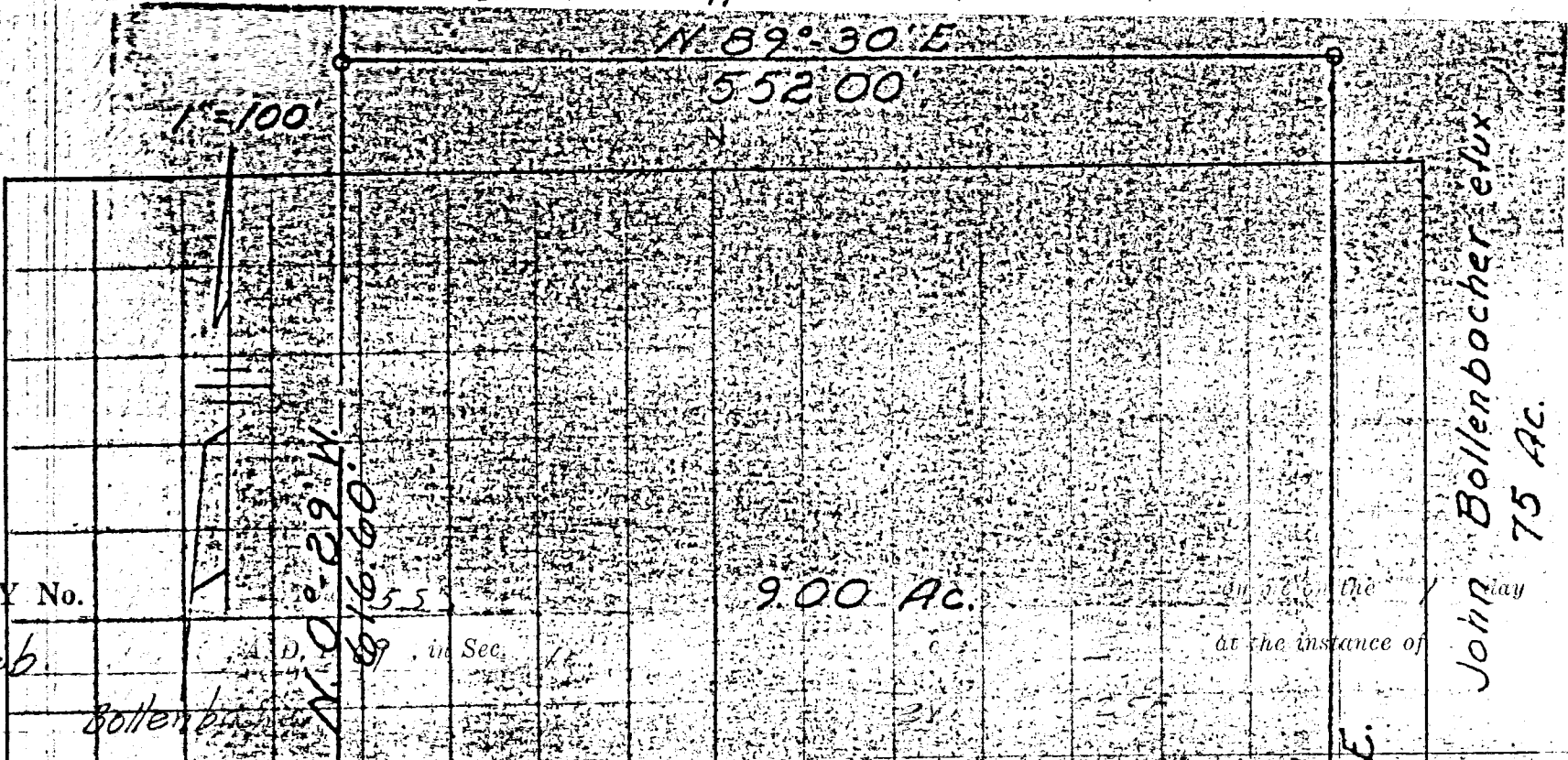

199

SURVEY No. _____ In Town 55 of Range 2 East. Plat and Notes of Survey made by me on the _____ day of Feb, A. D. 1969, in Sec. 18, Town 55, of Range 2E, at the instance of Bollenbacher Surveyor - Tevis # 5258

The Johnson-Watson Co., Dayton, Ohio - N-7609

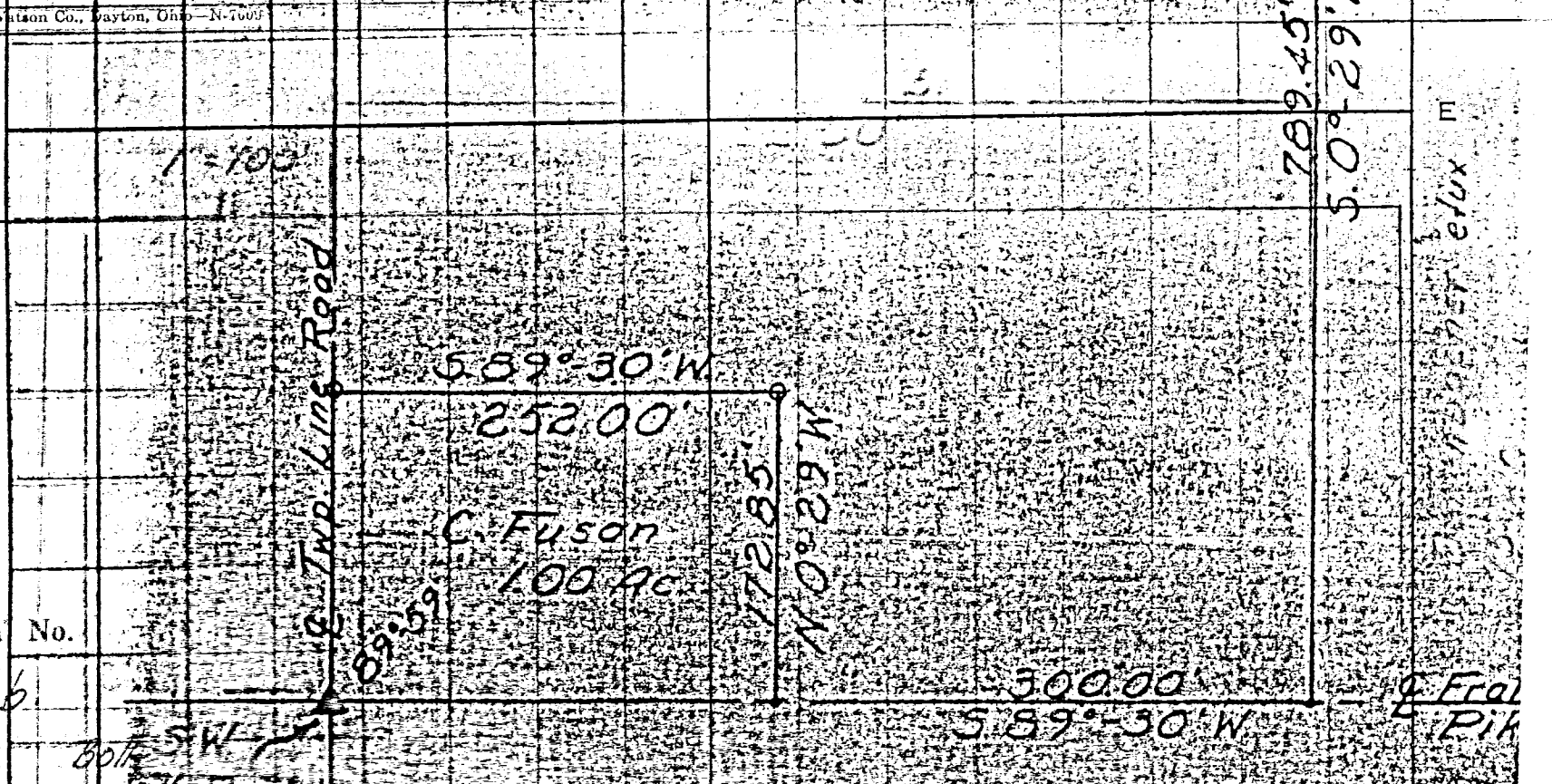

199

SURVEY No. _____ In Town 55 of Range 2 East. Plat and Notes of Survey made by me on the _____ day of Feb, A. D. 1969, in Sec. 18, Town 55, of Range 2E, at the instance of Bollenbacher Surveyor - Tevis # 5258

The Johnson-Watson Co., Dayton, Ohio - N-7609

ROLLENBACHER SURVEY
 HOPEWELL TOWNSHIP
 SECTION 18, TOWN 55, RANGE 2E
 MERCER COUNTY, OHIO
 February 1, 1969
 Surveyed by Donald L. Tevis
 Registered Surveyor 5258

0518300011
 0518300004
 05.18300012
 0518300006

199

SURVEY No. _____ In Town 55 of Range 2 East. Plat and Notes of Survey made by me on the _____ day of Feb, A. D. 1969, in Sec. 18, Town 55, of Range 2E, at the instance of Bollenbacher Surveyor - Tevis # 5258

The Johnson-Watson Co., Dayton, Ohio - N-7609

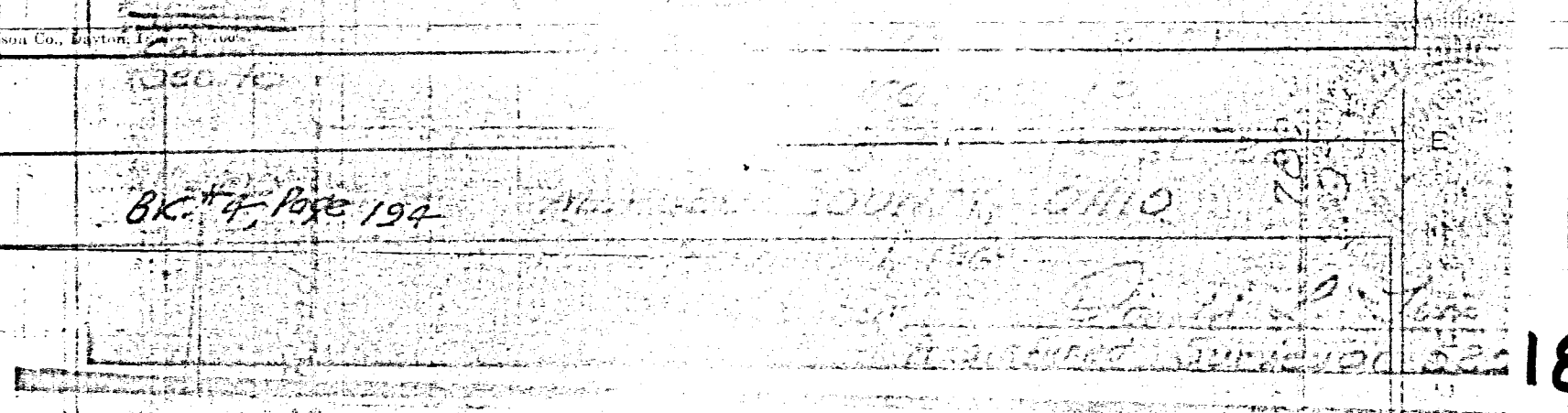

MERCER COUNTY.

Plat of N.W. 1/4 Sec 32 T5S R1E

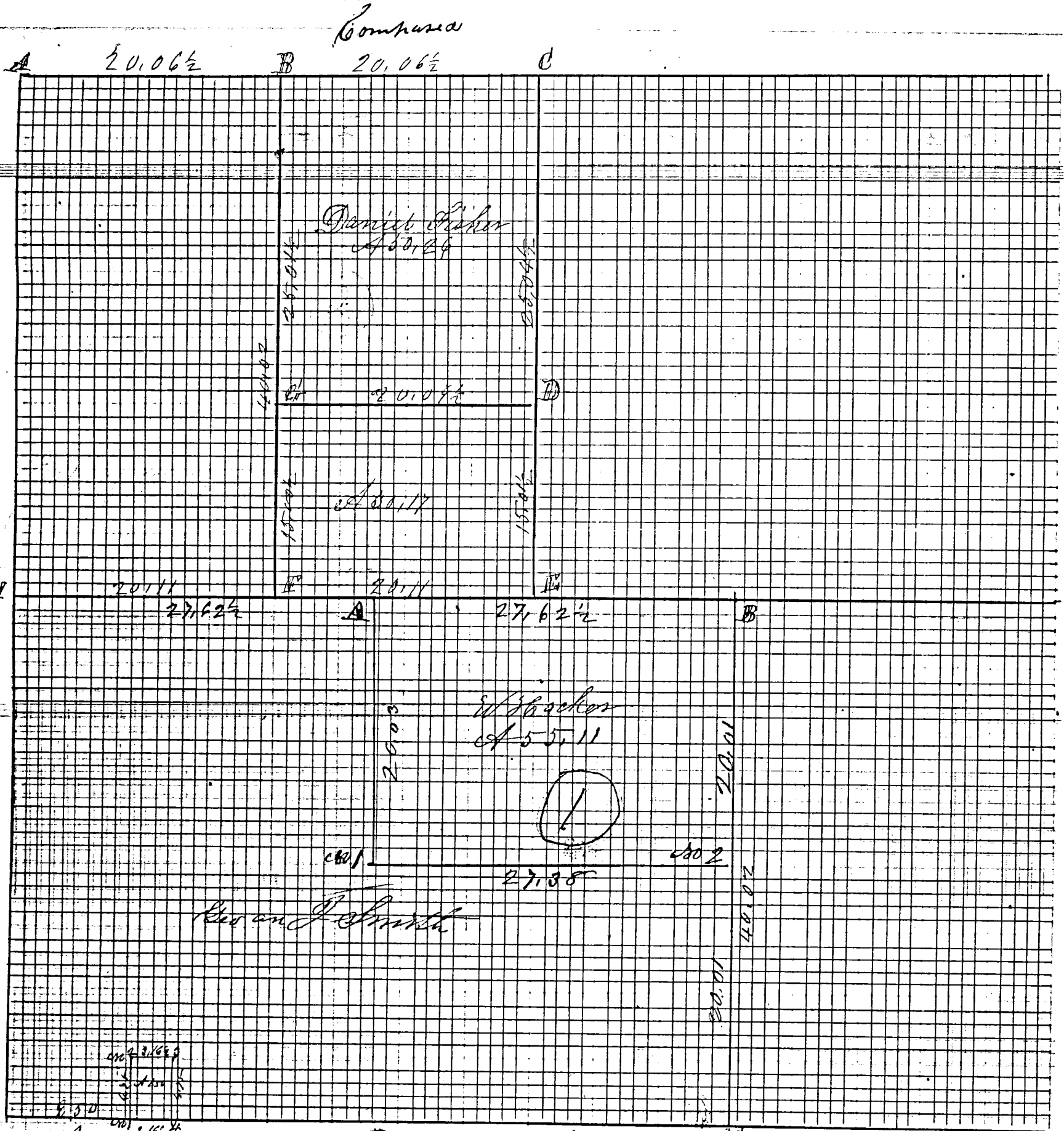

Plat of S.W. 1/4 of frac sec 18
from S. R. 2 East Hopewell Tp

Notes of Survey in the West 1/2 of N.W. fract sec 32 T5S, R1E for Welschmann Mueller
 No 1 being 26 chains east on Sp line from S.W. cor of sec 32 T5S, R1E Stake Sp corner 6 N47 W 3 1/2
 No 2 Stake 42.5 chains north of No 1 No 3 being 31 1/10 chains East of No 2 No 4 Stake
 on the Township line Maryland & N 55 W 42 1/2 gave Plat and notes
 The above is correct to the best of my knowledge and belief W. Schuyler
 Copied from Book 20 Page 78 by me July 23rd 1892 No Schuyler Surveyor

ROAD RECORD

①

Sec 18 T 5 S R 2 E Hopewell Township

Plat and notes of survey made in the South West fractional 1/4 of said Sec 18 T 5 S R 2 E on the 14th day of March 1879 at the Instance of W. Hacker -
 Chairmen: Sworn Anton Hacker and Geo J. Smith

- A Stone 10.8.4 Burr Oak Black Ash 13 N 80 E 61 Elm 36 E 53 1/2 W 31 1/2
- B Stone 12.7.6 Beech 18 E 19 E 13 Elm 24 N 12 E 10 1/2
- C Stake & Stone Burr Oak 20 E 5 1/2 W 17 1/2
- D Stone 16.8.5 Beech 12 N 41 E 33 Beech 24 E 24 W 36+
- No 1 Stake Stone 12.8.5 Beech 16 E 29 1/2 E 20 Beech 6 N 53 1/2 E 73 1/2
- No 2 Stake and Stone 14.9.6 no trees

The above I believe to be correct
 Hopewell Mar 14th 1879 Marcus Schuyler Esq of Mercer Co Ohio

The above notes of survey were this day copied by me and are correct to the best of my knowledge and belief
 Book 20 P 25
 Celina June 21st 1892
 Marcus Schuyler Surveyor

Sec 32 T 5 S R 1 E Blackrock Township

Plat and notes of survey made by me on the 21 and 22nd days of March 1879 at the Instance of Daniel Fisher in the N W 1/4 of Sec 32 T 5 S R 1 E. Chairmen Sworn Nathaniel Curles and Thomas Huston

- A Stake Burr Oak 12 E 44 1/2 W 45 - old witness tree grain
- B Stake Stone 16.7.6 White Ash 8 E 40 E 57 1/2 Elm 14 E 58 W 89 1/2
- C Stake Stone 18.11.9 Burr Oak 9 E 27 E 65 1/2 - new Hickory 9 E 25 1/2 W 63 1/2
- D Stake Cottonwood West 22 White Ash 4 N 72 E 14 1/2
- E Stake Stone 17.5.3 Black Ash 6 E 15 W 31 Burr Oak 12 N 82 E 46
- F Stake and Stone 12.10.3 Hickory 18 E 17 E 33 1/2 Burr Oak 40 E 30 1/2 W 74
- G Stake Sycamore 6 N 38 E 165 1/2 Hickory 6 E 68 1/2 E 148

The above is correct -
 March 22nd 1879 Marcus Schuyler Esq Surveyor of Mercer Co Ohio

The above notes of survey made by me and recorded in Book 20 Page 25 were this day copied by me and are correct to the best of my knowledge and belief
 Celina June 21st 1892 Marcus Schuyler Surveyor

Survey No 12. Plat and notes of survey, made by one in the N.E. 1/4 of sec 18 in Town 5 South of Range 2 East (Hopewell) on the 19th day of April A.D. 1859. At the instance of Henry Smith Chairman from Henry Smith, and Vincent Hacker, the bearings being taken from the established Meridian line in the County of Mercer Co. State of O. Plat drawn on a scale of 4 inches to a mile, the top being north. The length of lines are marked in chains and links or hundredths

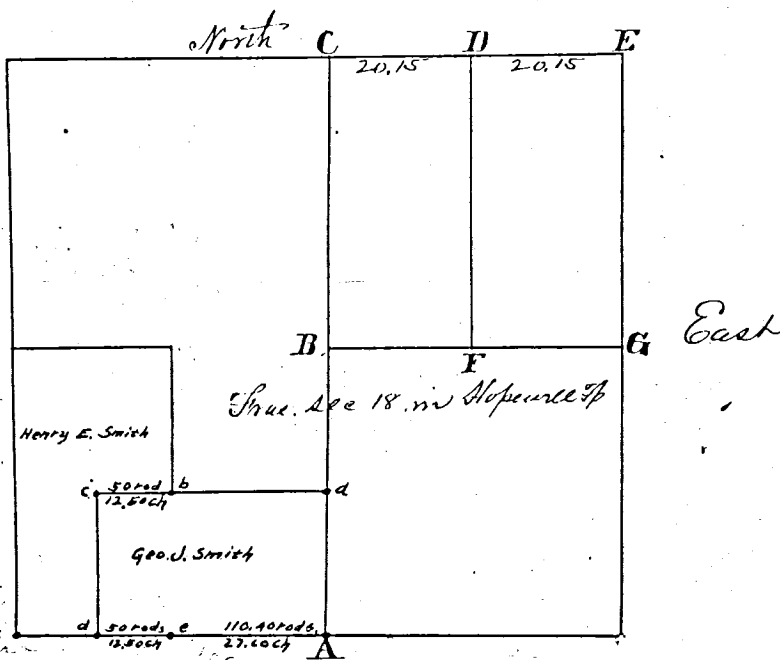

- A $S\frac{1}{4}$ post I find the Elm as in notes standing green marked also the B. Ash lying down also marked I drove stakes at said corner and marked Burr Oak 20 $S3\frac{1}{2}^{\circ}W 17\frac{1}{2}$
- B on a right line from C to A as run and corrected from C
- C the $N\frac{1}{4}$ post I find the 1 Beech as in notes standing green also the N° 9 Beech a growing with the original notes. I planted a stake deep brick bats and stone $13 \times 6 \times 6$. at said corner and marked Beech 10 $S15^{\circ}E 35$. Beech 18 $N33\frac{1}{2}^{\circ}W 51\frac{1}{2}$
- D on equal division of line. I planted stake deep and stone $12 \times 9 \times 6$ and marked Black ash 10 $S 62^{\circ}W 34$ + Burr Oak 10 $N 22^{\circ}E 24$
- E on an equal division of the line from G to B. Stake but no corner. the line being only run as far west as B.
- E N.E. corner of sec. I find the roots of both bearing trees and drove a stake a growing, therewith and marked new Beech 12 $N 78^{\circ}E 60\frac{3}{4}$ Hickory 16 $S 64^{\circ}W 7.8$
- G $E\frac{1}{4}$ post, I find both bearing trees standing green. drove stake

The above as far as surveyed I hereby certify to be correct.

Surveyors Office, Letchina

March 1st A.D. 1861.

Marcus Schuyler Surveyor of Mercer Co. Ohio

a Stone by Schuyler } Chainmen D.H. Smith & Albert Smith (Lewin)
b " " " }
c " " " } Survey to six corners between Henry E. Smith & Geo. J. Smith June 17th 1862
d " " " }
e " " " } Measured 50 rods, on ab produced & sec c.
f Scale, file bats & Stone } See d on line of 50rd. from e

205

Survey No 121. Plat and Notes of Survey made by me in the N W fractional quarter of Sec. 2 Town 5 S R 2 East on the 11th & 13th days of Jan. 1862. at the instance of Thomas May. Scale 4 inches to a mile. Chaimen sworn Caleb Mast and Jas Steen. Copied from Note book No 7 Page 63.

- A W¹/₄ Post. I find Beech 10. N 81 W 22. Standing dead and Stumps of Do. 14. S 76 E 18. all correct. I planted Stake deep and Stone 15. 12. 8. W. Elm 7 S 31¹/₂ E 76. Beech 18 S 47 W 55.
- B Stone corner planted by me in former Survey W Elm 6 S 29¹/₂ W 52 Beech 16. N 32¹/₂ W 31¹/₂
- C N¹/₄ Post made on equal division of N line Stake Hickory 6 N 68¹/₂ W 7 Sycamore 38 S 26 E 98¹/₂
- D Center of Sec. at crossing of right lines from 4 Posts. Stake brick bats and Stone 25. 20. 12. marked. Burr Oak 36 S 41¹/₂ E 166¹/₂ White Elm 9 S 42¹/₂ W 216¹/₂
- E Stake and Stone 10. 7. 5. Hickory 9 S 50¹/₂ E 30. Black Ash 6 N 71 E 30.

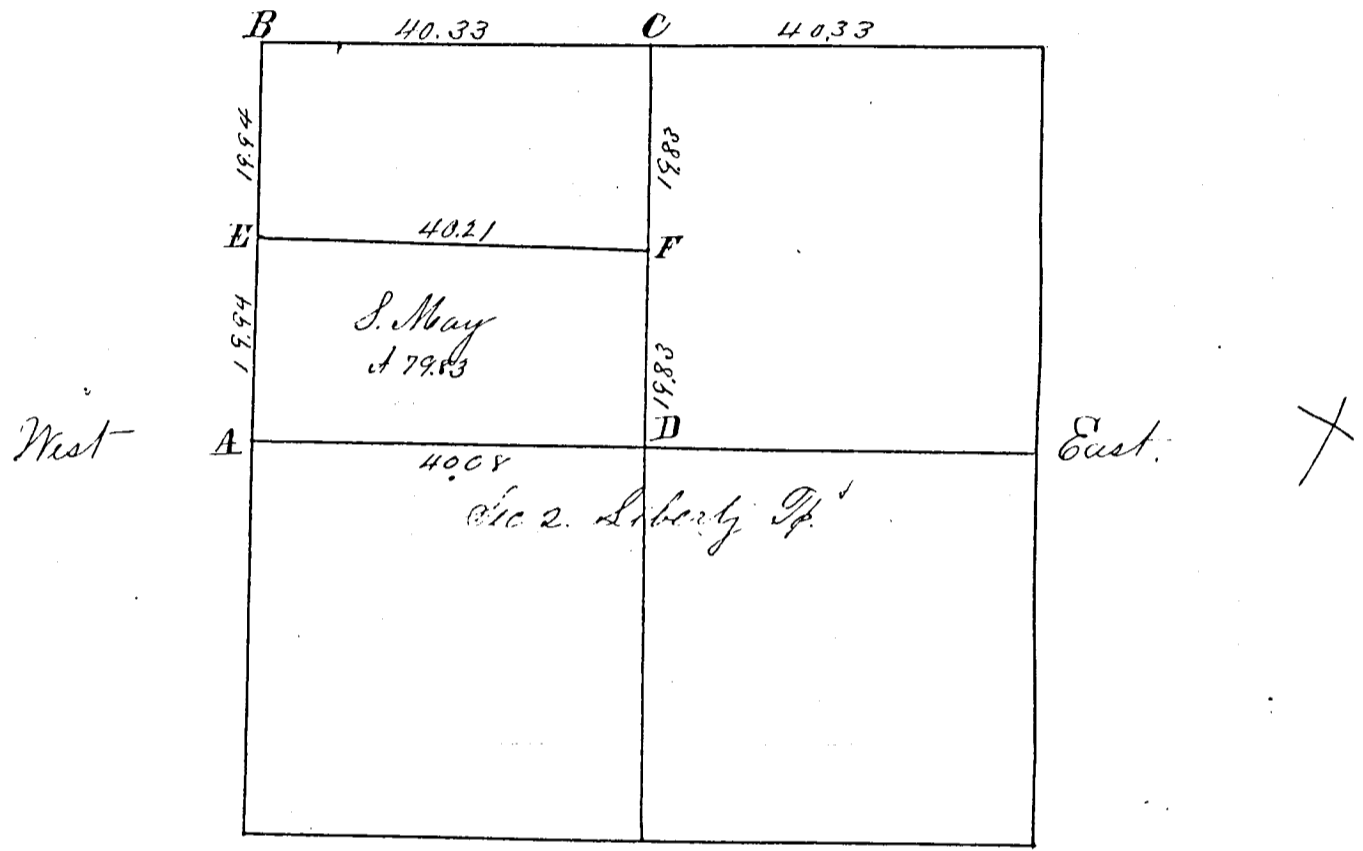

F Stake and Stone 10. 6. 6. White Ash 6 S 81¹/₂ W 78³/₄ Red Elm 6 S 74 W 65
 I certify the above Plat and Notes to be correct. Surveyors Office Indiana Ohio
 March 11th A.D. 1864. Marcus Schuyler Surveyor
 of Mercer County Ohio.
 Copied from Old Records by J. M. D. Ford
 Surveyor of Mercer County Ohio Jan 30 - 1889.

X Survey No 122. Plat and Notes of Survey made by me in the S E ¹/₄ of Sec. 18 Town 5 S R 2 E on the 11th day of Feb. 1862 at the instance of John Buracre. Chaimen sworn John Miller J^r and J. Buracre. Scale 4 inches to a mile. Copied from Note book No 7 Page 66

- A ³/₄ Post See Survey for Th. Smith Stake. B Burr Oak 18 N 55 W 71 Do 24 N 17¹/₂ W 55¹/₂. Stake on corrected line at equal division.
 - C S. E corner of Section. I find the original trees green
 - F ³/₄ Post witness trees standing green all correct
- I certify the above correct as far as Surveyed. Surveyors Office Indiana Ohio
 March 11 - 1864.

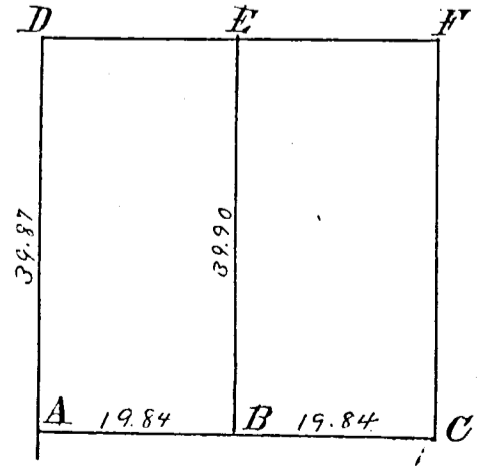

Marcus Schuyler Surveyor
 of Mercer County Ohio.
 Copied from Old Records by J. M. D. Ford
 Surveyor Jan. 30 - 1889.

Plot of N.W. frac 1/4 of frac sec 18 T5S. R2E East

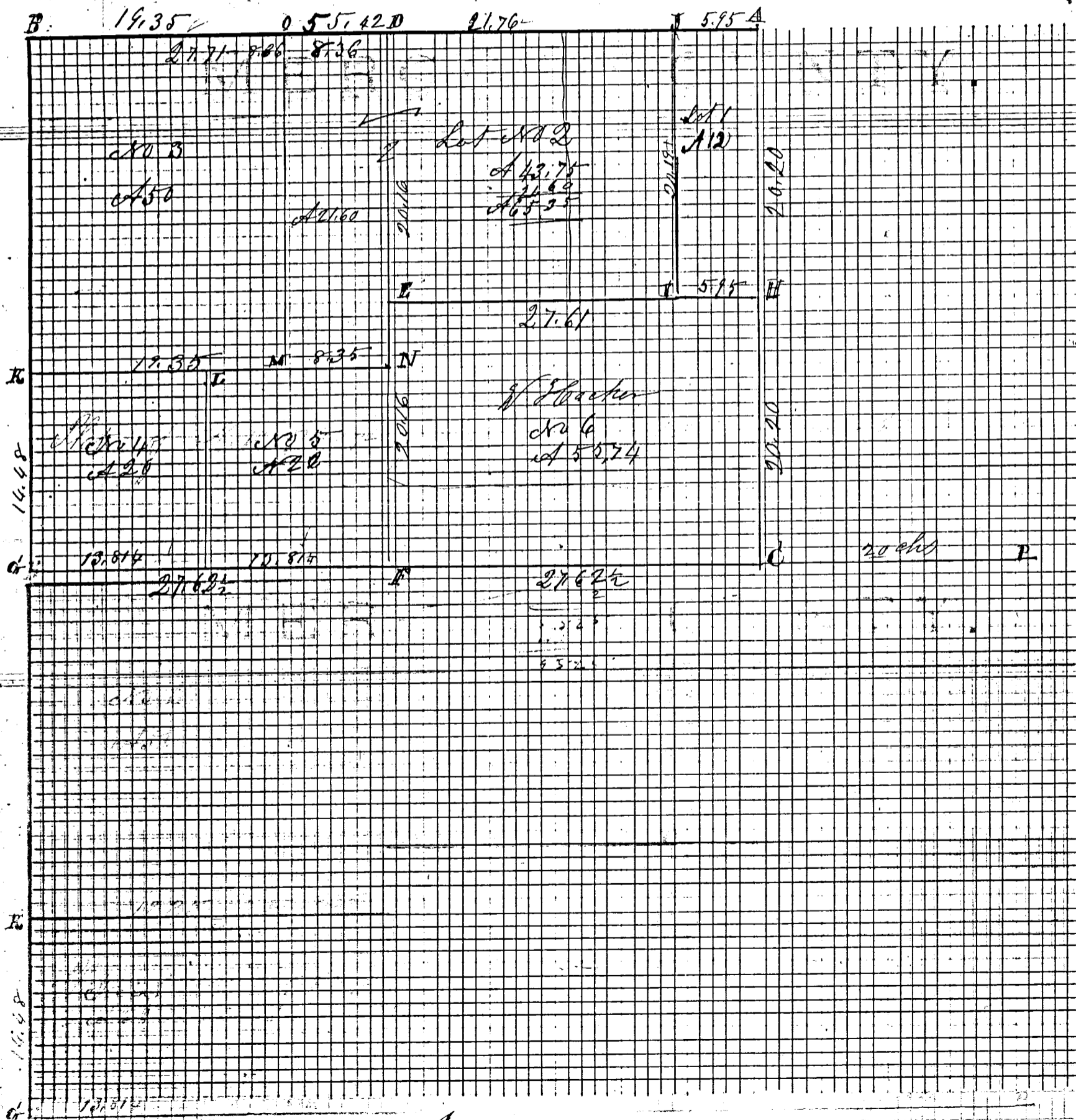

Inclosed

SURVEY BK. 3 ROAD RECORD

PAGE 70

Plot and Notes of Survey made by me in the N. W. 1/4
 14 of Sec 18 T. 28 N. R. 5 E of Range 2 East at the Instance of
 Wensel Hacker and others Chaimmen sworn William J. Cameron
 John Willenath Survey May 26th and June 7th 1871

A N. 1/4 East Stake and Stone

B Stake bat and Stone 14. 8. 4 Beech 14 S 43 E 66

C Stake bat Stone 12. 7. 6 Beech 6 S 19 E 13 Elm 24 N 12 E 10 1/2

D Stake Elm 20 S 17 1/2 E 89 Horn Oak 30 S 57 W 137 1/2

E Stake and Stone 10. 8. 6 Horn Oak 13 S 37 1/2 E 54 1/2 Beech 20 S 88 W 29

F Stake, Stone 12. 8. 4 Black Ash 13 N 80 E 61 Elm 36 S 3 1/2 W 31 1/2

G Stake and Stone 13. 7. 5 Beech 22 N 81 W 37 Beech 20 N 70 E 44

H Stake bat and Stone 8. 6. 6 no trees

I Stake and Stone 18. 12. 8 being 5. 95 chains West of H

J Stake and Stone 18. 10. 8 Elm 13 S 52 W 78 3/4

K Stake and Stone White Ash 3 N 22 E 47 Dog N 76 E 64

L Stake Beech 22 S 30 W 35 Horn Oak 15 N 30 E 58

M Stake Beech 18 S 76 E 43 Beech 12 S 3 W 50 1/2

N Stake Black Ash 20 S 11 W 57 1/2 Dog 14 N 22 W 8

O Stone 10. 8. 6 and Stake and bat no trees

P At the center of the East end of the cut out West center line

Stake and Stone 13. 7. 5 Beech 14 N 62 E 32 Hickory 20 S 67 W 32 1/2

The same being 20 chains East of O and marked P.

The above is correct to the best of my belief

June 8th 1871

M. Schuyler Cochran Member Co P

The above notes are copied by me from note Book 110 16 pgs 70. 71

May 19th 1892 and the same are correct to the best of my belief

Marcus Schuyler Surveyor

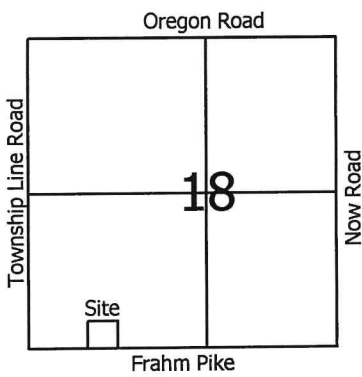

Scale: 1" = 100'

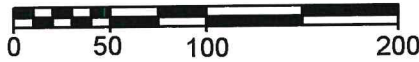

Legend:

- ▲ Cornerstone @ the S1/4 post of Section 18
- △ Cornerstone @ the SW corner of Section 18
- ⊙ 5/8" X 30" Iron pin w/cap set
- Iron pin found
- Railroad spike found
- ⊙ Iron pin found 30.0' from corner
- ⊗ Mag nail set

Note: Reference is made to a prior survey by myself dated 6-30-09

MINOR SUBDIVISION

1 Lot J. Weiss 4/4/19

Roger & Victoria Bollenbacher
Inst.# 20100002637

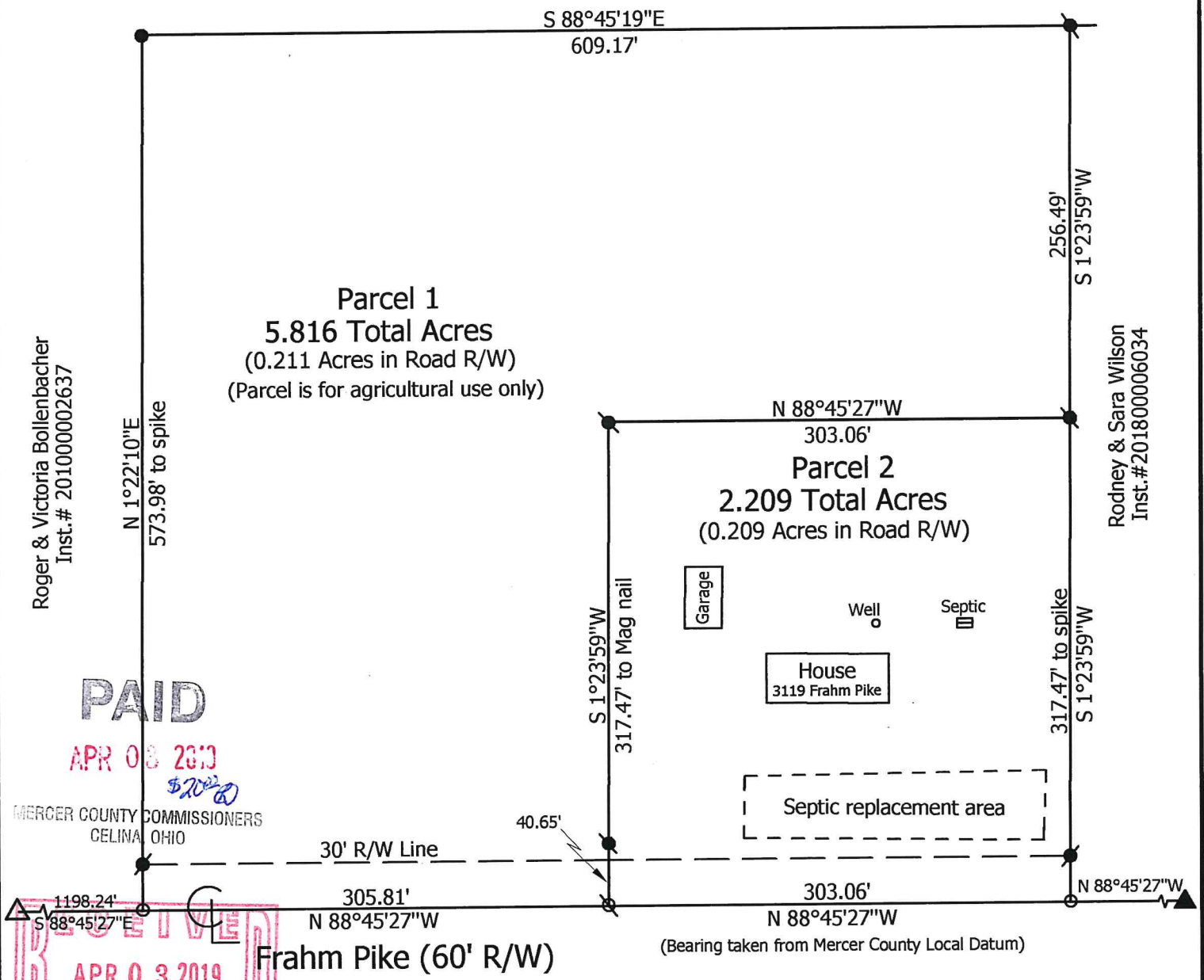

PAID

APR 08 2013

520.00

MERCER COUNTY COMMISSIONERS
CELINA, OHIO

RECEIVED
APR 03 2019
By Health Dept (MSK)

Marbaugh Land Surveying
1901 Carolina Court
Celina, Ohio 45822
(419) 586-4293

Kent Marbaugh
Kent B. Marbaugh P.S.7421



Vian Survey

State of: Ohio County: Mercer
 Township: Hopewell Sec: SW1/4 18 Town: 5S Range: 2E
 City/Village: _____ Subdivision: _____ Lot: _____
 Deed Ref: Inst.# 201600003346 Date Surveyed: 3-13-19

Approvals: *Michelle Kinimel* *Richard Couper* *Jason Moeller*
 Agency: Board of Health Township Zoning Inspector County Engineer
 Date: 4-3-19 4-3-2019

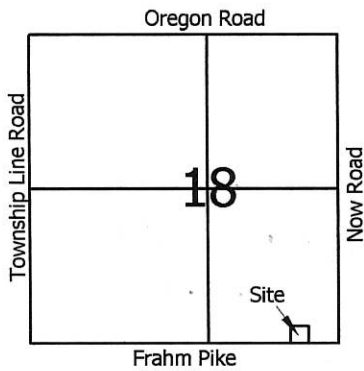

Scale: 1" = 80'

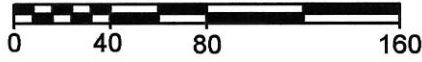

Legend:

- ▲ Cornerstone @ the S1/4 post of Section 18
- △ Mag nail @ the SE corner of Section 18
- Iron pin found from prior survey
- ⊗ Railroad spike found from prior survey
- 5/8" X 30" Iron pin w/cap set
- Mag nail set

Note: Reference is made to a survey by Alvin Spraley in Sept. 1991 with field work by myself & good friend Steven Kremer R.I.P.

Mark & Michelle Houts
Inst.# 201700002571

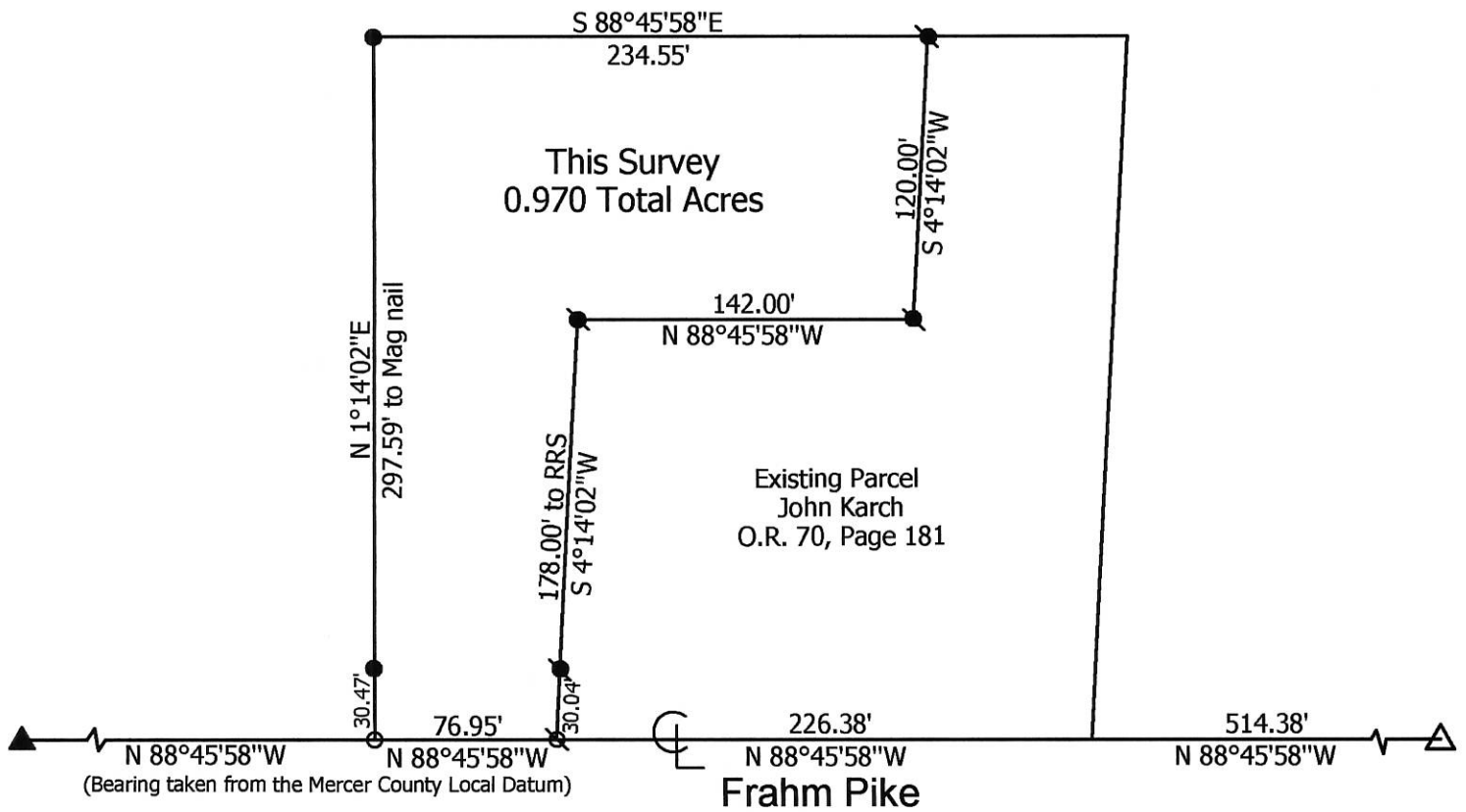

**Marbaugh
Land Surveying**

1901 Carolina Court
Celina, Ohio 45822
(419) 586-4293

Kent Marbaugh
Kent B. Marbaugh P.S.7421



Houts to Karch Survey

State of: Ohio County: Mercer
Township: Hopewell Sec: 18 Town: 5S Range: 2E
City/Village: _____ Subdivision: _____ Lot: _____
Deed Ref: _____ Inst.# 201700002571 Date Surveyed 10-17-17

Approvals: _____	_____	_____
Agency: Board of Health	Township Zoning Inspector	County Engineer
Date: _____		

05- D(18)

WILSON SURVEY

PART OF THE S.W. FRACTIONAL 1/4 OF SECTION 18, TOWN 5 SOUTH, RANGE 2 EAST, (HOPEWELL TOWNSHIP), MERCER COUNTY, OHIO.

OCTOBER 13, 2018

SCALE 1" = 200'



LEGEND

- △ = CORNERSTONE FOUND.
- = 5/8 INCH IRON BAR FOUND.
- ⦿ = RAILROAD SPIKE FOUND.
- = 5/8 INCH IRON BAR SET.
- ⊘ = MAG NAIL SET.

LOCATION SKETCH

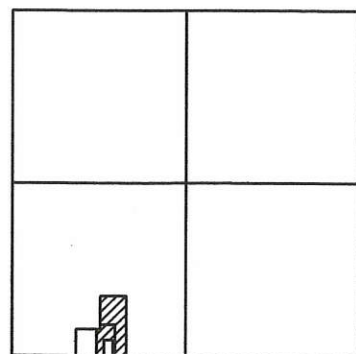

SECTION 18

S.W. COR. -
SEC. 18

1198.24'

☉ FRAHM PIKE (60' R/W)

608.87'

S 88°45'27" E 3649.26' (BEARING BASED ON MERCER CO. LOCAL GPS DATUM)

S. LINE S.W. FRACT. 1/4 - SEC. 18

30.00'

17.61'

1.104
ACRE
PARCEL

LINE TABLE

LINE	BEARING	DISTANCE
L1	N 01°23'59" E	320.51'
L2	S 88°45'27" E	150.00'
L3	S 01°23'59" W	320.51'

LINES 2 & 3 ARE TOTAL DISTANCES TO CENTERLINE/SEC. LINE

30' R/W LINE

150.00'

496.14'

1148.40'

S. 1/4 POST -
SEC. 18

S 01°18'51" W 703.26'

N 88°46'58" W 625.11'

S 01°18'51" W 50.00'

N 88°46'58" W 50.00'

TRACT TWO
18.153 ACRES
(0.342 AC. IN R/W)

SULLENBERGER ETAL
INST. # 2016-5767
19.657 AC. BY DEED

S 88°45'19" E 180.64'

TRACT ONE
1.500 ACRES
(0.033 AC. IN R/W)

N 88°45'19" W 626.14'
609.17'

8.025 AC. PARCEL

S 01°23'59" W 573.96' (T)

S 01°23'59" W 573.95' (T)

N 01°16'44" E 1327.51' (T)



NOTE: TRACT ONE IS AN ADD ON PARCEL TO THE 1.104 AC. PARCEL AND IS NOT A SEPARATE BUILDING LOT.

THIS PLAT REPRESENTS AN ACTUAL FIELD SURVEY PERFORMED UNDER MY SUPERVISION, AS DATED HEREIN.

James W. Geeslin

ATTEST: JAMES W. GEESLIN
PROFESSIONAL SURVEYOR 7764

SURVEY REFERENCES :

- 1) G. GEESLIN SURVEY, P.S. 5372, JULY 1982.
- 2) R. THOMPSON SURVEY, P.S. 5379.
- 3) K. MARBAUGH SURVEY, P.S. 7421, 6-30-09.

PERMANENT
PARCEL No.

Part of: Sec. T. R. Township

Grantor: Area Retained: Acres

Grantee: Area Retained: Acres

Deed References:

APPROVALS:

Board of Health

Township Zoning Officer

Mercer County Engineer

DATE:

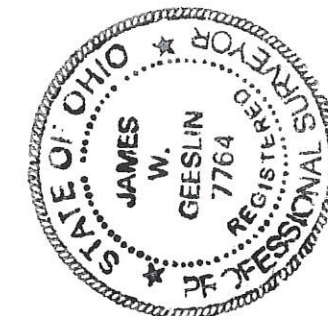

**GEESLIN
LAND SURVEYING**

525 S. SECOND ST.
COLDWATER, OHIO 45828

PHONE: (419)678-7233
geeslinsurveying@gmail.com