

Property Address: 530 E BOUNDARY ST,

DTE Code: 454



17-001100.0000

GIBSON TWP-FT RECOVERY CORP
 FT RECOVERY SD
 13-09-476-006

LEGAL INFORMATION

UNPLATTED S E SEC

NEIGH-GROUP: CIVIL50-50
 Acres:2.4500

M	4A
B	
C	1

RTS: 001-15-09
COOPER FARMS INC
 COOPER FARMS INC
 PO BOX 339
 FORT RECOVERY, OH 45846

COMMENT
 TY2018:Net Gen=\$5,058.98, Other Assessment=\$2.00
 NC20 40 X 60 STRG BLDG
 DE19 NC NOT STARTED
 DE18 COR LISTING. AUTO SALES HAS BEEN CONVERTED TO OFFICE
 DE17 DESKTOP RVW CHGS: COR SK

Sales Data							Date
Date	Amount	Deed:Conv#	Use	Valid	Lister:	TR	04/22/19
05/12/2017	350,000		WDC : 306	454	■	Pricer:	
05/16/1990	175,000		: F : 0	454	□	Reviewer:	
					□	Final:	
					□	Call Back:	
					□	Visit:	

VALUATION SUMMARY				
VALUE YEAR	2018	2017	2017	2014
REASON FOR CHANGE	MISC	RAPP	MISC	RAPP
ESTIMATED	29,400	29,400	27,440	27,440
MARKET VALUE	251,760	265,200	266,350	262,070
	TOTAL	281,160	293,790	289,510
ASSESSED	10,290	10,290	9,600	9,600
VALUE	88,120	92,820	93,220	91,720
	TOTAL	98,410	102,820	101,320

LAND TYPE	SIZE	M	RATE	C	INF	M	VALUE	C
IL:ICE Land	A:2.45		20,000				29,400	0
Totals:	Total Acres 2.4500						29,400	0

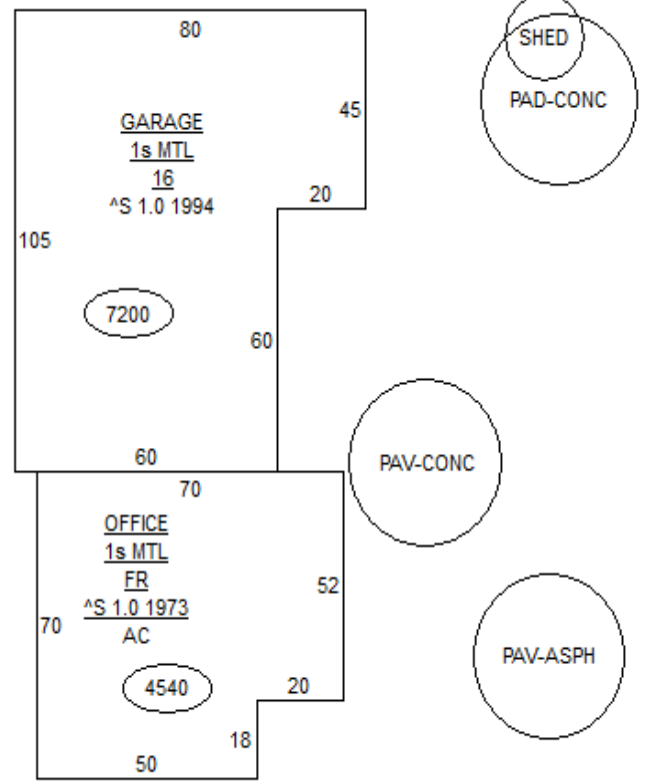

STREET/ROAD	TOPOGRAPHY	PU-UTILITIES-PR	ZONING
<input type="checkbox"/> PAVED	<input type="checkbox"/> LEVEL	<input type="checkbox"/> WATER	<input type="checkbox"/> AG-RES
<input type="checkbox"/> GRAVEL	<input type="checkbox"/> HIGH	<input type="checkbox"/> SEWER	<input checked="" type="checkbox"/> COMMERCIAL
<input type="checkbox"/> DIRT	<input type="checkbox"/> LOW	<input type="checkbox"/> GAS	<input type="checkbox"/> INDUSTRIAL
<input type="checkbox"/> SIDEWALKS	<input type="checkbox"/> ROLLING	<input type="checkbox"/> ELECTRIC	
<input type="checkbox"/> CURBS	<input type="checkbox"/> STANDARD	<input checked="" type="checkbox"/> STANDARD	

INFLUENCE FACTORS		
A. NO ROAD	E. SZ/SHAPE	I. WATER FRONT
B. TOPGRHY	F. RESTRICT	J. OTHER/CDU
C. Ex Front	G. WOOD LT	
D. QUANTITY	H. VACANCY	

		EX WALL	A	ROOFING	A	WINDOW	A	DOORS	A	FOUNDATION	A	FRAMING	A		
		STONE	<input type="checkbox"/>	GABLE/HIP	<input type="checkbox"/>	STORE FRT	<input type="checkbox"/>	OVERHEAD	<input type="checkbox"/>	SLAB	<input checked="" type="checkbox"/>	PRE ENG	<input type="checkbox"/>		
CLASS/QUALITY RANK		BRICK	<input type="checkbox"/>	SHED/FLAT	<input type="checkbox"/>	CASEMENT	<input type="checkbox"/>			CRAWL	<input type="checkbox"/>	STEEL	<input type="checkbox"/>		
A) FP STRUCT. STEEL FRAME	1. BASIC	CON BLK	<input type="checkbox"/>	CON DECK	<input type="checkbox"/>	DBLH	<input type="checkbox"/>			PILE/COL	<input type="checkbox"/>	REINF CONC	<input type="checkbox"/>		
B) R.C. FRAME	2. FAIR	WD/MTL	<input checked="" type="checkbox"/>	MTL DECK	<input checked="" type="checkbox"/>	SLIDE BY	<input type="checkbox"/>			REINFOR	<input type="checkbox"/>	CB/MASON	<input type="checkbox"/>		
C) MASONRY BEARING WALLS	3. AVE	ENAM STL	<input checked="" type="checkbox"/>	WD DECK	<input type="checkbox"/>	CANOPY	A			STEEL	<input type="checkbox"/>	FRAME	<input type="checkbox"/>		
D) WD OR STEEL FR EX. WALLS	4. GOOD	ALUM/VYL	<input type="checkbox"/>	METAL	<input type="checkbox"/>	LIGHTED	<input type="checkbox"/>	STEEL INS	<input type="checkbox"/>	BRICK	<input type="checkbox"/>	POLE	<input type="checkbox"/>		
S) METAL M) MILL P) POLE	5. EXCEL	CON PANEL	<input type="checkbox"/>	ASPH	<input type="checkbox"/>	SOFFITS	<input type="checkbox"/>	WOOD	<input type="checkbox"/>	STONE	<input type="checkbox"/>	TILT UP	<input type="checkbox"/>		
TOTAL AREA	PERIMETER	690	PLATE GLS	<input type="checkbox"/>	RUBBER	<input type="checkbox"/>	C S W	<input type="checkbox"/>	MTL	<input type="checkbox"/>	CON BLK	<input type="checkbox"/>	SANDWICH	<input type="checkbox"/>	
# STORIES	1	STORY HT	12	STUCCO	<input type="checkbox"/>	BUILT UP	<input type="checkbox"/>	FACADE	A	GLASS	<input type="checkbox"/>	FRAME	<input type="checkbox"/>	STANDARD	<input checked="" type="checkbox"/>
AGE		SPRINKLER		INSULATED	<input type="checkbox"/>	INSULATED	<input type="checkbox"/>			STANDARD	<input checked="" type="checkbox"/>	STANDARD	<input type="checkbox"/>		

H.V.A.C.		FLOORS				PARTITIONS					INTERIOR FINISH										
Electric	<input type="checkbox"/>	Electric Wall	<input type="checkbox"/>	CONCRETE	<input type="checkbox"/>	<input checked="" type="checkbox"/>	<input type="checkbox"/>	<input type="checkbox"/>	<input type="checkbox"/>	<input type="checkbox"/>	MASONRY	<input type="checkbox"/>	<input type="checkbox"/>	<input type="checkbox"/>	<input type="checkbox"/>	UNFINISHED	<input type="checkbox"/>	<input checked="" type="checkbox"/>	<input type="checkbox"/>	<input type="checkbox"/>	<input type="checkbox"/>
Forced Air Unit	<input type="checkbox"/>	Hot Water	<input type="checkbox"/>	WOOD	<input type="checkbox"/>	<input type="checkbox"/>	<input type="checkbox"/>	<input type="checkbox"/>	<input type="checkbox"/>	<input type="checkbox"/>	WD STUD	<input type="checkbox"/>	<input type="checkbox"/>	<input type="checkbox"/>	<input type="checkbox"/>	FINISH OPEN	<input type="checkbox"/>	<input checked="" type="checkbox"/>	<input type="checkbox"/>	<input type="checkbox"/>	<input type="checkbox"/>
Hot Water, Rad	<input type="checkbox"/>	Space/ Wall Furnace	<input type="checkbox"/>	TILE A Q V T	<input type="checkbox"/>	<input type="checkbox"/>	<input type="checkbox"/>	<input type="checkbox"/>	<input type="checkbox"/>	<input type="checkbox"/>	MTL STUD	<input type="checkbox"/>	<input type="checkbox"/>	<input type="checkbox"/>	<input type="checkbox"/>	FINISH DIV	<input type="checkbox"/>	<input checked="" type="checkbox"/>	<input type="checkbox"/>	<input type="checkbox"/>	<input type="checkbox"/>
Steam	<input type="checkbox"/>	Warm & Cld Air	<input checked="" type="checkbox"/>	CARPET	<input type="checkbox"/>	<input type="checkbox"/>	<input type="checkbox"/>	<input type="checkbox"/>	<input type="checkbox"/>	<input type="checkbox"/>	CEILINGS	B	1	2	3	U	PANEL	<input type="checkbox"/>	<input type="checkbox"/>	<input type="checkbox"/>	<input type="checkbox"/>
Ventilation	<input type="checkbox"/>	Heat Pump	<input type="checkbox"/>	ASPHALT	<input type="checkbox"/>	<input type="checkbox"/>	<input type="checkbox"/>	<input type="checkbox"/>	<input type="checkbox"/>	<input type="checkbox"/>	ACCUT/PANEL	<input type="checkbox"/>	<input type="checkbox"/>	<input type="checkbox"/>	<input type="checkbox"/>	<input type="checkbox"/>	PLASTER / DW	<input type="checkbox"/>	<input type="checkbox"/>	<input type="checkbox"/>	<input type="checkbox"/>
Package Unit	<input checked="" type="checkbox"/>	Ind TW Heat Pump	<input type="checkbox"/>	GRAVEL	<input type="checkbox"/>	<input type="checkbox"/>	<input type="checkbox"/>	<input type="checkbox"/>	<input type="checkbox"/>	<input type="checkbox"/>	PLASTER/DW	<input type="checkbox"/>	<input type="checkbox"/>	<input type="checkbox"/>	<input type="checkbox"/>	<input type="checkbox"/>	BLOCK	<input type="checkbox"/>	<input type="checkbox"/>	<input type="checkbox"/>	<input type="checkbox"/>
Hot & Cld Water	<input type="checkbox"/>	Evaporated Cool	<input type="checkbox"/>	DIRT	<input type="checkbox"/>	<input type="checkbox"/>	<input type="checkbox"/>	<input type="checkbox"/>	<input type="checkbox"/>	<input type="checkbox"/>	SUSP/OPEN	<input type="checkbox"/>	<input type="checkbox"/>	<input type="checkbox"/>	<input type="checkbox"/>	<input type="checkbox"/>	GLAZED TILE	<input type="checkbox"/>	<input type="checkbox"/>	<input type="checkbox"/>	<input type="checkbox"/>
Floor Furnace	<input type="checkbox"/>	Co-Ray-Vac	<input type="checkbox"/>	STANDARD	<input type="checkbox"/>						STANDARD	<input type="checkbox"/>					STANDARD	<input type="checkbox"/>			

Complete HVAC	<input type="checkbox"/>	No Heat	<input type="checkbox"/>	PLUMBING					LIGHTING				
Refrig. Cooling	<input type="checkbox"/>	Standard	<input type="checkbox"/>	NO PLUMBING					A				
				<input type="checkbox"/>					EXTRA FIXTURES				
				2 FIXTURE BATH					2				
				STANDARD					<input type="checkbox"/>				
				3 FIXTURE BATH					SODIUM VAP				
									<input type="checkbox"/>				
									MERCURY VAP				
									<input type="checkbox"/>				

ITEM	CONST	HT	SIZE X SIZE	FL	AREA	UNITS	AGE	REM	CND	GRD	\$/UNIT	UNADJUSTED \$	PHY	FC	EC	MARKET VALUE
A 901.002:Paving: Concrete		7140			11,595	ORS	1994		N	N	.00	0	0	0	0	0
B 901.001:Paving: Asphalt					14,940		1994		N	N	.00	0	0	0	0	0
C 901.002:Paving: Concrete			8 X 15	1	120		2017		A	A	3.00	360	50	0	0	180
D 499.066:Shed			8 X 10	1	80		2017		A	N	.00	0	0	0	0	0

ITEM	CONST	HT	SIZE X SIZE	FL	AREA	UNITS	AGE	REM	CND	GRD	\$/UNIT	UNADJUSTED \$	PHY	FC	EC	MARKET VALUE
A 447.000:Office: 1-2 story-walkup (per		12		1	4,540		1973	1987F	A	F	34.00	154,360	40	0	0	92,620
1 455.000:SHOP ADDITION		16		1	7,200		1994		A	A	26.00	187,200	17	0	0	155,380
2 900.068:AC				1	7,960		1973	1987F	A	A	1.00	7,960	55	0	0	3,580

AMENITY TOTAL																0
TOTAL IMPR															251,760	

COMMENTS

FRAMING IS RECORDED AS FIRE RESISTANT.

Property Address: 530 E BOUNDARY ST,

DTE Code: 454



17-001100.0000

GIBSON TWP-FT RECOVERY CORP
 FT RECOVERY SD
 13-09-476-006

LEGAL INFORMATION

UNPLATTED S E SEC

NEIGH-GROUP: CIVIL50-50
 Acres:2.4500

M	4A
B	
C	1

RTS: 001-15-09
COOPER FARMS INC
 COOPER FARMS INC
 PO BOX 339
 FORT RECOVERY, OH 45846

COMMENT

Sales Data							Date
Date	Amount	Deed:Conv#	Use	Valid	Lister:	TR	04/22/19
05/12/2017	350,000		WDC : 306	454	■	Pricer:	
05/16/1990	175,000		: F : 0	454	□	Reviewer:	
					□	Final:	
					□	Call Back:	
					□	Visit:	

VALUATION SUMMARY			
VALUE YEAR	2011		
REASON FOR CHANGE	RAPP		
ESTIMATED	LAND	27,440	
MARKET VALUE	IMPR	262,070	
	TOTAL	289,510	
ASSESSED	LAND	9,600	
VALUE	IMPR	91,720	
	TOTAL	101,320	

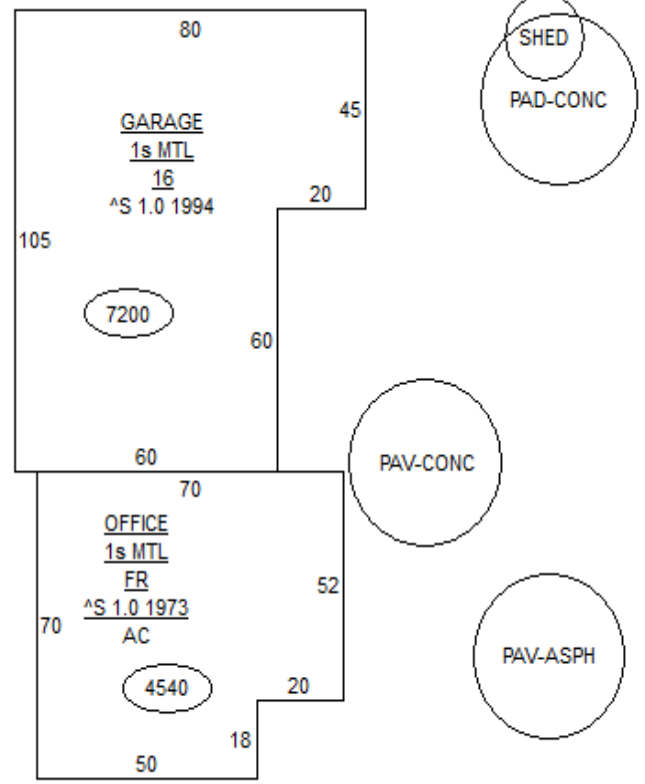

STREET/ROAD	TOPOGRAPHY	PU-UTILITIES-PR	ZONING
<input type="checkbox"/> PAVED	<input type="checkbox"/> LEVEL	<input type="checkbox"/> WATER	<input type="checkbox"/> AG-RES
<input type="checkbox"/> GRAVEL	<input type="checkbox"/> HIGH	<input type="checkbox"/> SEWER	<input checked="" type="checkbox"/> COMMERCIAL
<input type="checkbox"/> DIRT	<input type="checkbox"/> LOW	<input type="checkbox"/> GAS	<input type="checkbox"/> INDUSTRIAL
<input type="checkbox"/> SIDEWALKS	<input type="checkbox"/> ROLLING	<input type="checkbox"/> ELECTRIC	
<input type="checkbox"/> CURBS	<input type="checkbox"/> STANDARD	<input checked="" type="checkbox"/> STANDARD	

INFLUENCE FACTORS		
A. NO ROAD	E. SZ/SHAPE	I. WATER FRONT
B. TOPGRHY	F. RESTRICT	J. OTHER/CDU
C. Ex Front	G. WOOD LT	
D. QUANTITY	H. VACANCY	

LAND TYPE	SIZE	M	RATE	C	INF	M	VALUE	C
Totals:	Total Acres 2.4500						29,400	0
							29,400	

