



16-023100.0100

LINK GUSTAVE C & TESSA R

LINK GUSTAVE C & TESSA R
302 S WAYNE ST
FORT RECOVERY, OH 45846

GIBSON TWP / FT RECOVERY SD

13-23-400-003

LEGAL INFORMATION

PT SE SE

RTS: 001-15-23
Acres:4.4440

1 OF 1		
PROP. CLASS		
5	1	0
NEIGHBORHOOD		
009165-R150		
M	08	
B		
C	08	

	OWNERSHIP	ADDRESS	CITY	STATE	ZIP	DATE	AMOUNT	DEED:CONV#	JS	VALID
1	LINK GUSTAVE C & TESSA R	302 S WAYNE ST	FORT RECOVERY	OH	45846	03/05/2018	315,000	WDC : 109	<input type="checkbox"/>	<input checked="" type="checkbox"/>
2	SCHMITZ DANIEL L & MARILYN	1909 SHARPSBURG RD	FT RECOVERY	OH	45846		0	: 0	<input type="checkbox"/>	<input type="checkbox"/>
3							0	0	<input type="checkbox"/>	<input type="checkbox"/>

X:	<input type="checkbox"/> TTO	LISTER: NS	DATE: 10/13/2004	TIME: 01:14:52 PM	<input checked="" type="checkbox"/> LETTER	<input type="checkbox"/> LETTER REC'D	GIS CODE
STREET/ROAD	TOPOGRAPHY	PU-UTILITIES-PR	NEIGHBORHOOD	INFLUENCE FACTORS		PROPERTY LOCATION	
<input checked="" type="checkbox"/> PAVED	<input checked="" type="checkbox"/> LEVEL	<input type="checkbox"/> WATER	<input type="checkbox"/> IMPROVING	<input type="checkbox"/> A. NO ROAD	<input type="checkbox"/> F. RESTRICT	1909 SHARPSBURG RD, FT RECOVERY	
<input type="checkbox"/> GRAVEL	<input type="checkbox"/> HIGH	<input type="checkbox"/> SEWER	<input checked="" type="checkbox"/> STATIC	<input type="checkbox"/> B. TOPGRHY	<input type="checkbox"/> G. WOOD LT	COMMENT TY2018:Net Gen=\$1,771.14, Other Assessment=\$0.72 DE09 PER DATA MAILER CORRECTED PLMG DE17 DESKTOP RVW CHG:ADD PAT, BW, ENCLOSE OMP	
<input type="checkbox"/> DIRT	<input type="checkbox"/> LOW	<input type="checkbox"/> GAS	<input type="checkbox"/> DECLINING	<input type="checkbox"/> C. Ex Front	<input type="checkbox"/> H. VACANCY		
<input type="checkbox"/> SIDEWALKS	<input type="checkbox"/> ROLLING	<input type="checkbox"/> ELECTRIC	<input type="checkbox"/> OLD	<input type="checkbox"/> D. QUANTITY	<input type="checkbox"/> I. WATER FRONT		
<input type="checkbox"/> CURBS	<input type="checkbox"/> STANDARD	<input checked="" type="checkbox"/> STANDARD	<input type="checkbox"/> STANDARD	<input type="checkbox"/> E. SZ/SHAPE	<input type="checkbox"/> J. OTHER/CDU		

LAND COMPUTATIONS							
LAND TYPE	SIZE	M	RATE	C	INF	M VALUE	C
HS:Home Site	AC:1	16500				16,500	0
SM:Small Acreage	AC:3.444	6400				22,000	0
Total Acres: 4.4440					TOTAL	38,500	0

VALUATION SUMMARY							
VALUE YEAR		2017	2017	2014	2013	2011	2009
REASON FOR CHANGE		RAPP	MISC	RAPP	MISC	RAPP	MISC
APPRAISED	LAND	38,500	39,300	39,300	37,000	37,000	35,600
VALUE	IMPR	111,000	107,600	105,000	99,300	99,300	122,500
	TOTAL	149,500	146,900	144,300	136,300	136,300	158,100
ASSESSED	LAND	13,480	13,760	13,760	12,950	12,950	12,460
	IMPR	38,850	37,660	36,750	34,760	34,760	42,880
	TOTAL	52,330	51,420	50,510	47,710	47,710	55,340

OCCUPANCY	EXTERIOR	FLOOR	AREA	CONST	VALUE
<input checked="" type="checkbox"/> SNGL FMLY	<input type="checkbox"/> WOOD	1	1736	FR	126,870
<input type="checkbox"/> DUPLEX	<input type="checkbox"/> STUCCO	.5	300	FR	16,000
<input type="checkbox"/> TRIPLEX	<input checked="" type="checkbox"/> ALM/VYNL				
<input type="checkbox"/> CONVR	<input type="checkbox"/> CONC BLK				
<input type="checkbox"/> MOBILE HM	<input type="checkbox"/> METAL				
<input type="checkbox"/> BI/L TRI/L	<input type="checkbox"/> BRICK				
<input type="checkbox"/> MOD/MAN	<input type="checkbox"/> STONE				

ROOFING	ROOF TYPE
<input checked="" type="checkbox"/> METAL	<input checked="" type="checkbox"/> GABLE
<input type="checkbox"/> SLT/TLE	<input type="checkbox"/> HIP
<input type="checkbox"/> SHINGLES	<input type="checkbox"/> GAMBREL
<input type="checkbox"/> SHAKES	<input type="checkbox"/> MANSARD
<input type="checkbox"/> COMPOSITE	<input type="checkbox"/> FLAT

FLOORS	B	1	2	3	U
CONCRETE	<input type="checkbox"/>	<input type="checkbox"/>	<input type="checkbox"/>	<input type="checkbox"/>	<input type="checkbox"/>
WOOD	<input type="checkbox"/>	<input type="checkbox"/>	<input type="checkbox"/>	<input type="checkbox"/>	<input type="checkbox"/>
TILE/COMPO	<input type="checkbox"/>	<input checked="" type="checkbox"/>	<input type="checkbox"/>	<input type="checkbox"/>	<input type="checkbox"/>
CARPET	<input type="checkbox"/>	<input checked="" type="checkbox"/>	<input checked="" type="checkbox"/>	<input type="checkbox"/>	<input type="checkbox"/>

INT. FINISH	B	1	2	3	U
PLASTER/DW	<input type="checkbox"/>	<input checked="" type="checkbox"/>	<input checked="" type="checkbox"/>	<input type="checkbox"/>	<input type="checkbox"/>
PANELING	<input type="checkbox"/>	<input checked="" type="checkbox"/>	<input type="checkbox"/>	<input type="checkbox"/>	<input type="checkbox"/>
UNFINISHED	<input type="checkbox"/>	<input type="checkbox"/>	<input type="checkbox"/>	<input type="checkbox"/>	<input type="checkbox"/>

ACCOMMODATIONS				
# OF ROOMS	4	3		
BEDROOMS	3			
FIREPLACES				

HEAT & AC	B	1	2	3	U
NO HEAT	<input type="checkbox"/>	<input type="checkbox"/>	<input type="checkbox"/>	<input type="checkbox"/>	<input type="checkbox"/>
CTRL HEAT	<input type="checkbox"/>	<input checked="" type="checkbox"/>	<input checked="" type="checkbox"/>	<input type="checkbox"/>	<input type="checkbox"/>
HW/STEAM	<input type="checkbox"/>	<input type="checkbox"/>	<input type="checkbox"/>	<input type="checkbox"/>	<input type="checkbox"/>
ELECTRIC	<input type="checkbox"/>	<input type="checkbox"/>	<input type="checkbox"/>	<input type="checkbox"/>	<input type="checkbox"/>
HEAT PUMP	<input type="checkbox"/>	<input type="checkbox"/>	<input type="checkbox"/>	<input type="checkbox"/>	<input type="checkbox"/>
FLR/WALL	<input type="checkbox"/>	<input type="checkbox"/>	<input type="checkbox"/>	<input type="checkbox"/>	<input type="checkbox"/>
STVE/SPCE	<input type="checkbox"/>	<input type="checkbox"/>	<input type="checkbox"/>	<input type="checkbox"/>	<input type="checkbox"/>
GEOTHERMAL	<input type="checkbox"/>	<input type="checkbox"/>	<input type="checkbox"/>	<input type="checkbox"/>	<input type="checkbox"/>
OUTSIDE	<input type="checkbox"/>	<input type="checkbox"/>	<input type="checkbox"/>	<input type="checkbox"/>	<input type="checkbox"/>
CTRL A/C	<input type="checkbox"/>	<input checked="" type="checkbox"/>	<input checked="" type="checkbox"/>	<input type="checkbox"/>	<input type="checkbox"/>

PLUMBING	BASE
X FULL BATH	1
X HALF BATH	
X FIXTURES	1

BSMT	AREA	VALUE
	700	9,100

SUBTOTAL			VALUE
MULTI-FAMILY #	0		0
BSMT FINISH	0 S.F.		0
FIREPLACE #	0		0
HEATING	0 S.F.		0
AIR COND	2,036 S.F.		3,050
PLUMBING #	4		4,400
GARAGES & CARPORTS			13,400
EXTRA FEATURES			11,300
SUBTOTAL			184,120
GRADE FACTOR			105 %
UNADJUSTED VALUE			193,330
FACTOR			100 %

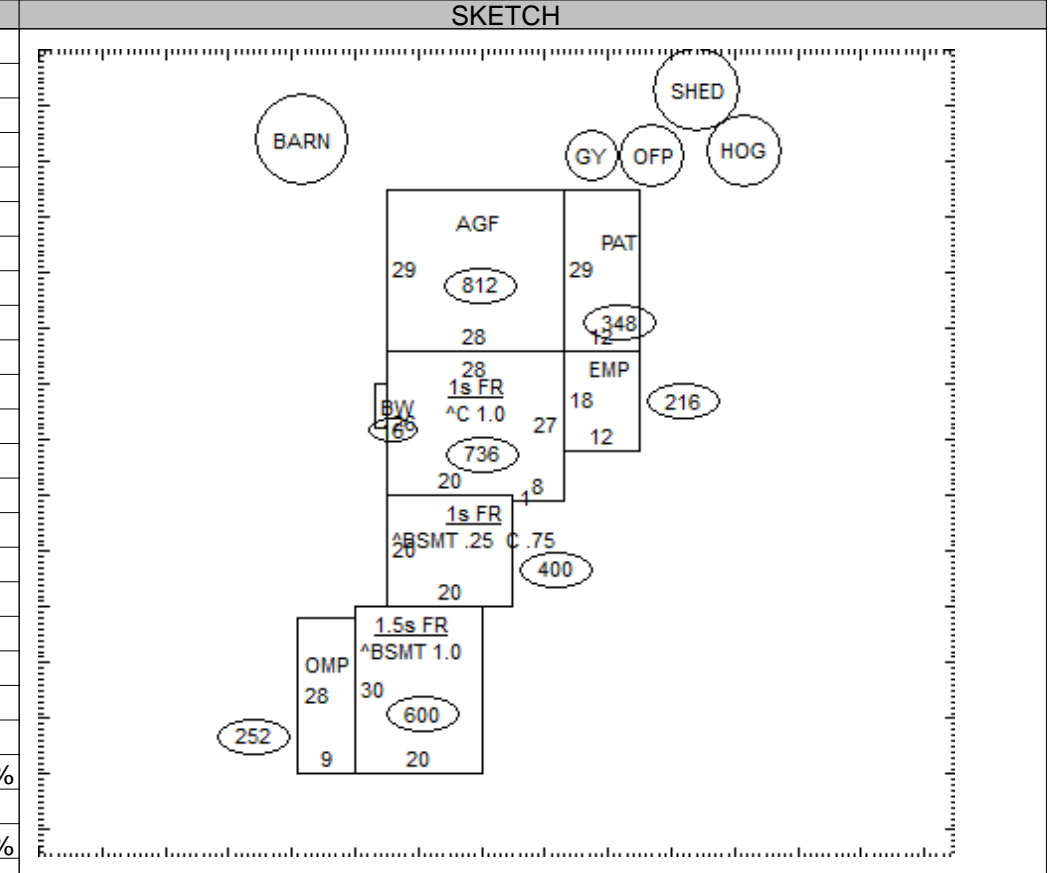

OCCUPANCY	ST.HT	SIZE	AREA	GRADE	PRICE	AGE	REMD	CND	UNADJ VAL	PHYS	PHYS VAL	FUNC	TRUE VAL
DWELLING	1.5	SK	2,036	C+		1900	1996	A	193,330	45	106,330		109,500
1 OFP	8	12x20	240	D	11.66	1980		A	2,800	68	900		900
2 Barn	14	36x60	2,160	C	8.00	1920		A	17,280	95	860	DFLT50	400
3 Granary	12	20x22	440	D	5.60	1920		F	2,460	95	120	DFLT50	100
4 Hog Hse	8	17x25	425	D	7.20	1920		A	3,060	95	150	DFLT50	100
5 Shed		10x12	120	C		1990		F		48			0
6													
7													
8													
9													
10													
11													

16-023100.0100	TOTAL	111,000
----------------	-------	---------

COMMENTS

48 L/F 8' HI BRK 120 L/F 4' HI BRK
 Dwelling has an Economic Factor of 103%