

1 OF 2		
PROP. CLASS		
5	1	0
NEIGHBORHOOD		
095CL50-CL50		
M	02	
B		
C	07	

09-104400.0000

KIEFER WILLIAM J & CHERYL A

KIEFER WILLIAM J & CHERYL A
3601 ST RTE 703
CELINA, OH 45822

LEGAL INFORMATION

ANCIL & EDNA PHELPS SUBD.
E PT LOT 7
ALSO E END LOT 6 & PT 5 RTS: 003-06-23 LOT#: 7
Acres:0.3483 M:0.0000

	OWNERSHIP	ADDRESS	CITY	STATE	ZIP	DATE	AMOUNT	DEED:CONV#	JS	VALID
1	KIEFER WILLIAM J & CHERYL A	3601 ST RTE 703	CELINA	OH	45822	03/07/2017	102,000	WDC : 144	<input type="checkbox"/>	<input checked="" type="checkbox"/>
2	FARRELL DANNY, FARRELL NIXON STEVEN	3601 ST RTE 703	CELINA	OH	45822	03/07/2017	0	QCE : X : 0	<input type="checkbox"/>	<input type="checkbox"/>
3	FARRELL JOHN P	5342 LAKE DR	CELINA	OH	45822	05/13/2013	0	QCE : X : 0	<input type="checkbox"/>	<input type="checkbox"/>

X: TTO LISTER: DA DATE: 04/06/2005 TIME: 12:00:00 AM LETTER LETTER REC'D GIS CODE

STREET/ROAD	TOPOGRAPHY	PU-UTILITIES-PR	NEIGHBORHOOD	INFLUENCE FACTORS				PROPERTY LOCATION		
<input type="checkbox"/> PAVED <input checked="" type="checkbox"/> GRAVEL <input type="checkbox"/> DIRT <input type="checkbox"/> SIDEWALKS <input type="checkbox"/> CURBS	<input checked="" type="checkbox"/> LEVEL <input type="checkbox"/> HIGH <input type="checkbox"/> LOW <input type="checkbox"/> ROLLING <input type="checkbox"/> STANDARD	<input type="checkbox"/> WATER <input type="checkbox"/> SEWER <input type="checkbox"/> GAS <input type="checkbox"/> ELECTRIC <input checked="" type="checkbox"/> STANDARD	<input type="checkbox"/> IMPROVING <input checked="" type="checkbox"/> STATIC <input type="checkbox"/> DECLINING <input type="checkbox"/> OLD <input type="checkbox"/> STANDARD	<input type="checkbox"/> A. NO ROAD <input type="checkbox"/> B. TOPGRHY <input checked="" type="checkbox"/> C. Ex Front <input type="checkbox"/> D. QUANTITY <input type="checkbox"/> E. SZ/SHAPE	<input type="checkbox"/> F. RESTRICT <input type="checkbox"/> G. WOOD LT <input type="checkbox"/> H. VACANCY <input type="checkbox"/> I. WATER FRONT <input type="checkbox"/> J. OTHER/CDU	5342 LAKE DR, COMMENT TY2018:Net Gen=\$1,994.62, Other Assessment=\$0.00 DE17 MMH NOW ON PERMANENT FOUNDATION/ADD TO REAL ESTATE DE07 RMV MHH DE17 DESKTOP RVW CHG: MOVE EX FEATURES TO MH CARD, ADD SHED DE18 REMOVE OWN OCC didn't return app				
LAND COMPUTATIONS				INF	M	VALUE	C			
F:Front	F110 D150	ST500 DP100 ADJ500	C:0.1	49,500	0					
				TOTAL	49,500	0				

VALUATION SUMMARY							
VALUE YEAR	2017	2017	2017	2017	2014	2011	
REASON FOR CHANGE	RAPP	RCLS	MISC	MISC	RAPP	RAPP	
APPRAISED	LAND	49,500	49,500	49,500	49,500	49,500	
VALUE	IMPR	76,800	79,800	79,800	6,600	16,800	
	TOTAL	126,300	129,300	129,300	56,100	66,300	
ASSESSED	LAND	17,330	17,330	17,330	17,330	17,330	
VALUE	IMPR	26,880	27,930	27,930	2,310	5,880	
	TOTAL	44,210	45,260	45,260	19,640	23,210	

OCCUPANCY	EXTERIOR	FLOOR	AREA	CONST	VALUE
<input checked="" type="checkbox"/> SNGL FMLY <input type="checkbox"/> DUPLEX <input type="checkbox"/> TRIPLEX <input type="checkbox"/> CONVR <input type="checkbox"/> MOBILE HM <input type="checkbox"/> BI/L TRI/L <input type="checkbox"/> MOD/MAN	<input type="checkbox"/> WOOD <input type="checkbox"/> STUCCO <input checked="" type="checkbox"/> ALM/VYNL <input type="checkbox"/> CONC BLK <input type="checkbox"/> METAL <input type="checkbox"/> BRICK <input type="checkbox"/> STONE	1	1620	FR	121,030

ROOFING	ROOF TYPE
<input type="checkbox"/> METAL <input type="checkbox"/> SLT/TLE <input checked="" type="checkbox"/> SHINGLES <input type="checkbox"/> SHAKES <input type="checkbox"/> COMPOSITE	<input checked="" type="checkbox"/> GABLE <input type="checkbox"/> HIP <input type="checkbox"/> GAMBREL <input type="checkbox"/> MANSARD <input type="checkbox"/> FLAT

FLOORS	B	1	2	3	U
CONCRETE	<input type="checkbox"/>	<input type="checkbox"/>	<input type="checkbox"/>	<input type="checkbox"/>	<input type="checkbox"/>
WOOD	<input type="checkbox"/>	<input type="checkbox"/>	<input type="checkbox"/>	<input type="checkbox"/>	<input type="checkbox"/>
TILE/COMPO	<input type="checkbox"/>	<input checked="" type="checkbox"/>	<input type="checkbox"/>	<input type="checkbox"/>	<input type="checkbox"/>
CARPET	<input type="checkbox"/>	<input checked="" type="checkbox"/>	<input type="checkbox"/>	<input type="checkbox"/>	<input type="checkbox"/>

INT. FINISH	B	1	2	3	U
PLASTER/DW	<input type="checkbox"/>	<input type="checkbox"/>	<input type="checkbox"/>	<input type="checkbox"/>	<input type="checkbox"/>
PANELING	<input type="checkbox"/>	<input checked="" type="checkbox"/>	<input type="checkbox"/>	<input type="checkbox"/>	<input type="checkbox"/>
UNFINISHED	<input type="checkbox"/>	<input type="checkbox"/>	<input type="checkbox"/>	<input type="checkbox"/>	<input type="checkbox"/>

ACCOMMODATIONS	# OF ROOMS	5	6	7	8
		5			
	BEDROOMS	3			

HEAT & AC	B	1	2	3	U
NO HEAT	<input type="checkbox"/>	<input type="checkbox"/>	<input type="checkbox"/>	<input type="checkbox"/>	<input type="checkbox"/>
CTRL HEAT	<input type="checkbox"/>	<input checked="" type="checkbox"/>	<input type="checkbox"/>	<input type="checkbox"/>	<input type="checkbox"/>
HW/STEAM	<input type="checkbox"/>	<input type="checkbox"/>	<input type="checkbox"/>	<input type="checkbox"/>	<input type="checkbox"/>
ELECTRIC	<input type="checkbox"/>	<input type="checkbox"/>	<input type="checkbox"/>	<input type="checkbox"/>	<input type="checkbox"/>
HEAT PUMP	<input type="checkbox"/>	<input type="checkbox"/>	<input type="checkbox"/>	<input type="checkbox"/>	<input type="checkbox"/>
FLR/WALL	<input type="checkbox"/>	<input type="checkbox"/>	<input type="checkbox"/>	<input type="checkbox"/>	<input type="checkbox"/>
STVE/SPCE	<input type="checkbox"/>	<input type="checkbox"/>	<input type="checkbox"/>	<input type="checkbox"/>	<input type="checkbox"/>
GEOHERMAL	<input type="checkbox"/>	<input type="checkbox"/>	<input type="checkbox"/>	<input type="checkbox"/>	<input type="checkbox"/>
OUTSIDE	<input type="checkbox"/>	<input type="checkbox"/>	<input type="checkbox"/>	<input type="checkbox"/>	<input type="checkbox"/>
CTRL A/C	<input type="checkbox"/>	<input checked="" type="checkbox"/>	<input type="checkbox"/>	<input type="checkbox"/>	<input type="checkbox"/>

PLUMBING	BASE
X FULL BATH	<input type="checkbox"/>
X HALF BATH	<input type="checkbox"/>
X FIXTURES	<input type="checkbox"/>

SUBTOTAL	121,030
MULTI-FAMILY #	0
BSMT FINISH	0 S.F.
FIREPLACE #	0
HEATING	0 S.F.
AIR COND	1,620 S.F.
PLUMBING #	3
GARAGES & CARPORTS	0
EXTRA FEATURES	4,600
SUBTOTAL	131,360
GRADE FACTOR	80 %
UNADJUSTED VALUE	105,090
FACTOR	100 %

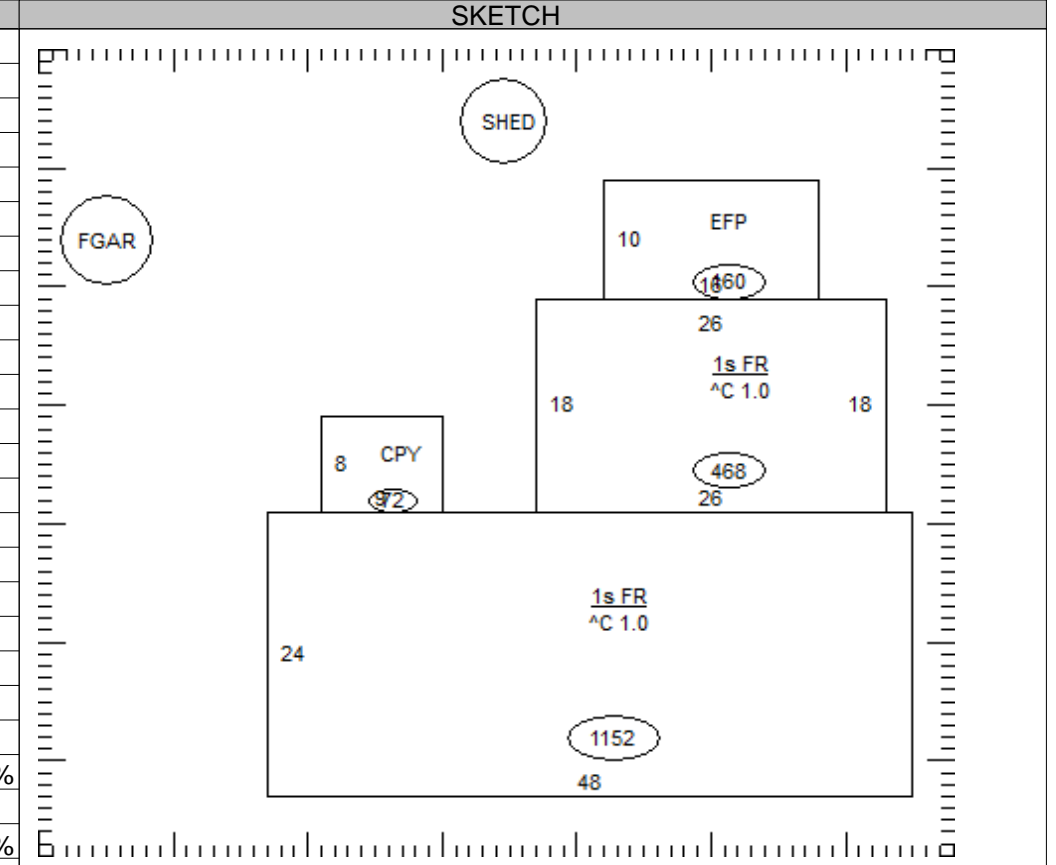

OCCUPANCY	ST.HT	SIZE	AREA	GRADE	PRICE	AGE	REMD	CND	UNADJ VAL	PHYS	PHYS VAL	FUNC	TRUE VAL
DWELLING	1	SK	1,620	D		1986		A	105,090	30	73,560		72,100
1 Gar - Frame	8	24x24	576	C	15.80	1986		A	9,100	57	3,910		3,900
2 Shed		10x16	160	C	9.00	1990		A	1,440	47	760		800
3													
4													
5													
6													
7													
8													
9													
10													
11													

09-104400.0000 TOTAL 76,800

COMMENTS

Dwelling has an Economic Factor of 98%



09-104400.0000

FRANKLIN TWP / CELINA SD

09-23-151-015

2 OF 2		
PROP. CLASS		
5	1	0
NEIGHBORHOOD		
095CL50-CL50		
M	02	
B		
C	07	

KIEFER WILLIAM J & CHERYL A

KIEFER WILLIAM J & CHERYL A
3601 ST RTE 703
CELINA, OH 45822

LEGAL INFORMATION

ANCIL & EDNA PHELPS SUBD.
E PT LOT 7
ALSO E END LOT 6 & PT 5 RTS: 003-06-23 LOT#: 7
Acres:0.3483 M:0.0000

	OWNERSHIP	ADDRESS	CITY	STATE	ZIP	DATE	AMOUNT	DEED:CONV#	JS	VALID
1	FARRELL JOHN P ETUX	5342 LAKE DR	CELINA	OH	45822		0	:0	<input type="checkbox"/>	<input type="checkbox"/>
2							0	0	<input type="checkbox"/>	<input type="checkbox"/>
3							0	0	<input type="checkbox"/>	<input type="checkbox"/>

X: TTO LISTER: DA DATE: 04/06/2005 TIME: 12:00:00 AM LETTER LETTER REC'D GIS CODE

STREET/ROAD	TOPOGRAPHY	PU-UTILITIES-PR	NEIGHBORHOOD	INFLUENCE FACTORS		PROPERTY LOCATION
<input type="checkbox"/> PAVED <input checked="" type="checkbox"/> GRAVEL <input type="checkbox"/> DIRT <input type="checkbox"/> SIDEWALKS <input type="checkbox"/> CURBS	<input checked="" type="checkbox"/> LEVEL <input type="checkbox"/> HIGH <input type="checkbox"/> LOW <input type="checkbox"/> ROLLING <input type="checkbox"/> STANDARD	<input type="checkbox"/> WATER <input type="checkbox"/> SEWER <input type="checkbox"/> GAS <input type="checkbox"/> ELECTRIC <input checked="" type="checkbox"/> STANDARD	<input type="checkbox"/> IMPROVING <input checked="" type="checkbox"/> STATIC <input type="checkbox"/> DECLINING <input type="checkbox"/> OLD <input type="checkbox"/> STANDARD	<input type="checkbox"/> A. NO ROAD <input type="checkbox"/> B. TOPGRHY <input checked="" type="checkbox"/> C. Ex Front <input type="checkbox"/> D. QUANTITY <input type="checkbox"/> E. SZ/SHAPE	<input type="checkbox"/> F. RESTRICT <input type="checkbox"/> G. WOOD LT <input type="checkbox"/> H. VACANCY <input type="checkbox"/> I. WATER FRONT <input type="checkbox"/> J. OTHER/CDU	5342 LAKE DR, COMMENT

LAND COMPUTATIONS							
LAND TYPE	SIZE	M	RATE	C	INF	M	VALUE C
					TOTAL		49,500 0

VALUATION SUMMARY

VALUE YEAR	REASON FOR CHANGE	APPRaised	IMPR	TOTAL	ASSESSED	IMPR	TOTAL

OCCUPANCY	EXTERIOR
<input type="checkbox"/> SNGL FMLY	<input type="checkbox"/> WOOD
<input type="checkbox"/> DUPLEX	<input type="checkbox"/> STUCCO
<input type="checkbox"/> TRIPLEX	<input type="checkbox"/> ALM/VYNL
<input type="checkbox"/> CONVR	<input type="checkbox"/> CONC BLK
<input type="checkbox"/> MOBILE HM	<input type="checkbox"/> METAL
<input type="checkbox"/> BI/L TRI/L	<input type="checkbox"/> BRICK
<input type="checkbox"/> MOD/MAN	<input type="checkbox"/> STONE
ROOFING	ROOF TYPE
<input type="checkbox"/> METAL	<input type="checkbox"/> GABLE
<input type="checkbox"/> SLT/TLE	<input type="checkbox"/> HIP
<input type="checkbox"/> SHINGLES	<input type="checkbox"/> GAMBREL
<input type="checkbox"/> SHAKES	<input type="checkbox"/> MANSARD
<input type="checkbox"/> COMPOSITE	<input type="checkbox"/> FLAT

FLOOR	AREA	CONST	VALUE
SUBTOTAL			0
FLOORS		B 1 2 3 U	MULTI-FAMILY # 0
CONCRETE	<input type="checkbox"/>	<input type="checkbox"/>	BSMT FINISH 0 S.F.
WOOD	<input type="checkbox"/>	<input type="checkbox"/>	FIREPLACE # 0
TILE/COMPO	<input type="checkbox"/>	<input type="checkbox"/>	HEATING 0 S.F.
CARPET	<input type="checkbox"/>	<input type="checkbox"/>	AIR COND 0 S.F.
INT. FINISH		B 1 2 3 U	PLUMBING # 0
PLASTER/DW	<input type="checkbox"/>	<input type="checkbox"/>	GARAGES & CARPORTS 0
PANELING	<input type="checkbox"/>	<input type="checkbox"/>	EXTRA FEATURES 0
UNFINISHED	<input type="checkbox"/>	<input type="checkbox"/>	SUBTOTAL 0
ACCOMMODATIONS			GRADE FACTOR %
# OF ROOMS	<input type="checkbox"/>	<input type="checkbox"/>	UNADJUSTED VALUE 0
BEDROOMS	<input type="checkbox"/>	<input type="checkbox"/>	FACTOR %
FIREPLACES	<input type="checkbox"/>	<input type="checkbox"/>	
HEAT & AC	B 1 2 3 U		
NO HEAT	<input type="checkbox"/>	<input type="checkbox"/>	
CTRL HEAT	<input type="checkbox"/>	<input type="checkbox"/>	
HW/STEAM	<input type="checkbox"/>	<input type="checkbox"/>	
ELECTRIC	<input type="checkbox"/>	<input type="checkbox"/>	
HEAT PUMP	<input type="checkbox"/>	<input type="checkbox"/>	
FLR/WALL	<input type="checkbox"/>	<input type="checkbox"/>	
STVE/SPCE	<input type="checkbox"/>	<input type="checkbox"/>	
GEO THERMAL	<input type="checkbox"/>	<input type="checkbox"/>	
OUTSIDE	<input type="checkbox"/>	<input type="checkbox"/>	
CTRL A/C	<input type="checkbox"/>	<input type="checkbox"/>	
PLUMBING	BASE <input type="checkbox"/>		
X FULL BATH	<input type="checkbox"/>	<input type="checkbox"/>	
X HALF BATH	<input type="checkbox"/>	<input type="checkbox"/>	
X FIXTURES	<input type="checkbox"/>	<input type="checkbox"/>	

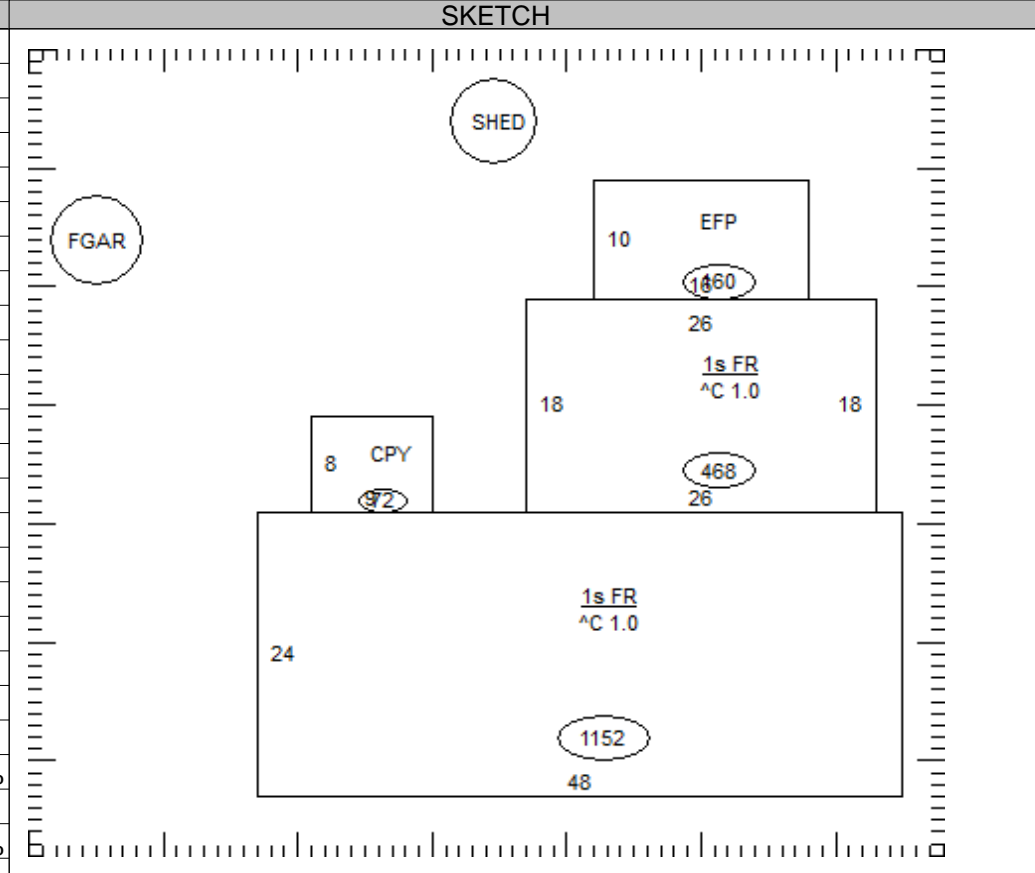

OCCUPANCY	ST.HT	SIZE	AREA	GRADE	PRICE	AGE	REMD	CND	UNADJ VAL	PHYS	PHYS VAL	FUNC	TRUE VAL
DWELLING		SK											
1													
2													
3													
4													
5													
6													
7													
8													
9													
10													
11													

09-104400.0000

TOTAL 0

COMMENTS