

1 OF 1		
PROP. CLASS		
5	1	0
NEIGHBORHOOD		
095LA20-LA20		
M	05F	
B		
C	23	

09-023500.0000

STACHLER JERRY B & NANETTE

STACHLER JERRY B & NANETTE
4440 FAIRGROUND RD
CELINA, OH 45822

LEGAL INFORMATION

LAKES SUBDIVISION
ALSO SECTION GROUND
RTS: 003-06-20 LOT#: 10

	OWNERSHIP	ADDRESS	CITY	STATE	ZIP	DATE	AMOUNT	DEED:CONV#	JS	VALID
1	STACHLER JERRY B &	4440 FAIRGROUND RD	CELINA	OH	45822	08/21/2018	155,000	WDC : 625	<input type="checkbox"/>	<input checked="" type="checkbox"/>
2	KENNEDY M DALE & LOIS A	14990 LOCK TWO RD	BOTKINS	OH	45306	08/28/2000	208,000	: A : 0	<input type="checkbox"/>	<input type="checkbox"/>
3							0	0	<input type="checkbox"/>	<input type="checkbox"/>

X: TTO LISTER: DA DATE: 04/26/2005 TIME: 12:00:00 AM LETTER LETTER REC'D GIS CODE

STREET/ROAD	TOPOGRAPHY	PU-UTILITIES-PR	NEIGHBORHOOD	INFLUENCE FACTORS	PROPERTY LOCATION	
<input type="checkbox"/> PAVED <input checked="" type="checkbox"/> GRAVEL <input type="checkbox"/> DIRT <input type="checkbox"/> SIDEWALKS <input type="checkbox"/> CURBS	<input checked="" type="checkbox"/> LEVEL <input type="checkbox"/> HIGH <input type="checkbox"/> LOW <input type="checkbox"/> ROLLING <input type="checkbox"/> STANDARD	<input type="checkbox"/> WATER <input type="checkbox"/> SEWER <input type="checkbox"/> GAS <input checked="" type="checkbox"/> ELECTRIC <input type="checkbox"/> STANDARD	<input type="checkbox"/> IMPROVING <input checked="" type="checkbox"/> STATIC <input type="checkbox"/> DECLINING <input type="checkbox"/> OLD <input type="checkbox"/> STANDARD	<input type="checkbox"/> A. NO ROAD <input type="checkbox"/> B. TOPGRHY <input type="checkbox"/> C. Ex Front <input type="checkbox"/> D. QUANTITY <input type="checkbox"/> E. SZ/SHAPE	<input type="checkbox"/> F. RESTRICT <input type="checkbox"/> G. WOOD LT <input type="checkbox"/> H. VACANCY <input type="checkbox"/> I. WATER FRONT <input type="checkbox"/> J. OTHER/CDU	5435 KARAFIT ROAD, LOT #10 , CELINA COMMENT TY2018:Net Gen=\$1,629.44, Other Assessment=\$0.00 DE15 CORRECTED LOT SIZE PER MAPPING

LAND COMPUTATIONS

LAND TYPE	SIZE	M	RATE	C	INF	M	VALUE	C
F:Front	F140 D160	ST250	DP103	ADJ258			36,100	0
						TOTAL	36,100	0

VALUATION SUMMARY

VALUE YEAR	2017	2015	2014	2011
REASON FOR CHANGE	RAPP	MISC	RAPP	RAPP
APPRAISED VALUE	36,100	42,200	37,100	31,700
	IMPR	69,800	66,200	56,600
	TOTAL	105,900	103,300	88,300
ASSESSED VALUE	12,640	14,770	12,990	11,100
	IMPR	24,430	23,170	19,810
	TOTAL	37,070	36,160	30,910

OCCUPANCY	EXTERIOR	FLOOR	AREA	CONST	VALUE
<input checked="" type="checkbox"/> SNGL FMLY	<input type="checkbox"/> WOOD	1	1408	FR	110,750
<input type="checkbox"/> DUPLEX	<input type="checkbox"/> STUCCO				
<input type="checkbox"/> TRIPLEX	<input checked="" type="checkbox"/> ALM/VYNL				
<input type="checkbox"/> CONVR	<input type="checkbox"/> CONC BLK				
<input type="checkbox"/> MOBILE HM	<input type="checkbox"/> METAL				
<input type="checkbox"/> BI/L TRI/L	<input type="checkbox"/> BRICK				
<input type="checkbox"/> MOD/MAN	<input type="checkbox"/> STONE				
ROOFING	ROOF TYPE				
<input type="checkbox"/> METAL	<input type="checkbox"/> GABLE				
<input type="checkbox"/> SLT/TLE	<input checked="" type="checkbox"/> HIP				
<input checked="" type="checkbox"/> SHINGLES	<input type="checkbox"/> GAMBREL				
<input type="checkbox"/> SHAKES	<input type="checkbox"/> MANSARD				
<input type="checkbox"/> COMPOSITE	<input type="checkbox"/> FLAT				
SUBTOTAL					110,750
FLOORS	B	1	2	3	U
CONCRETE	<input type="checkbox"/>	<input type="checkbox"/>	<input type="checkbox"/>	<input type="checkbox"/>	<input type="checkbox"/>
WOOD	<input type="checkbox"/>	<input type="checkbox"/>	<input type="checkbox"/>	<input type="checkbox"/>	<input type="checkbox"/>
TILE/COMPO	<input type="checkbox"/>	<input checked="" type="checkbox"/>	<input type="checkbox"/>	<input type="checkbox"/>	<input type="checkbox"/>
CARPET	<input type="checkbox"/>	<input checked="" type="checkbox"/>	<input type="checkbox"/>	<input type="checkbox"/>	<input type="checkbox"/>
INT. FINISH	B	1	2	3	U
PLASTER/DW	<input type="checkbox"/>	<input checked="" type="checkbox"/>	<input type="checkbox"/>	<input type="checkbox"/>	<input type="checkbox"/>
PANELING	<input type="checkbox"/>	<input checked="" type="checkbox"/>	<input type="checkbox"/>	<input type="checkbox"/>	<input type="checkbox"/>
UNFINISHED	<input type="checkbox"/>	<input type="checkbox"/>	<input type="checkbox"/>	<input type="checkbox"/>	<input type="checkbox"/>
ACCOMMODATIONS					
# OF ROOMS		3			
BEDROOMS		2			
FIREPLACES					
HEAT & AC	B	1	2	3	U
NO HEAT	<input type="checkbox"/>	<input type="checkbox"/>	<input type="checkbox"/>	<input type="checkbox"/>	<input type="checkbox"/>
CTRL HEAT	<input type="checkbox"/>	<input checked="" type="checkbox"/>	<input type="checkbox"/>	<input type="checkbox"/>	<input type="checkbox"/>
HW/STEAM	<input type="checkbox"/>	<input type="checkbox"/>	<input type="checkbox"/>	<input type="checkbox"/>	<input type="checkbox"/>
ELECTRIC	<input type="checkbox"/>	<input type="checkbox"/>	<input type="checkbox"/>	<input type="checkbox"/>	<input type="checkbox"/>
HEAT PUMP	<input type="checkbox"/>	<input type="checkbox"/>	<input type="checkbox"/>	<input type="checkbox"/>	<input type="checkbox"/>
FLR/WALL	<input type="checkbox"/>	<input type="checkbox"/>	<input type="checkbox"/>	<input type="checkbox"/>	<input type="checkbox"/>
STVE/SPCE	<input type="checkbox"/>	<input type="checkbox"/>	<input type="checkbox"/>	<input type="checkbox"/>	<input type="checkbox"/>
GEOHERMAL	<input type="checkbox"/>	<input type="checkbox"/>	<input type="checkbox"/>	<input type="checkbox"/>	<input type="checkbox"/>
OUTSIDE	<input type="checkbox"/>	<input type="checkbox"/>	<input type="checkbox"/>	<input type="checkbox"/>	<input type="checkbox"/>
CTRL A/C	<input type="checkbox"/>	<input type="checkbox"/>	<input type="checkbox"/>	<input type="checkbox"/>	<input type="checkbox"/>
PLUMBING	BASE <input checked="" type="checkbox"/>				
X FULL BATH		1			
X HALF BATH					
X FIXTURES					
MULTI-FAMILY #					0
BSMT FINISH					0 S.F.
FIREPLACE #					0
HEATING					0 S.F.
AIR COND					0 S.F.
PLUMBING #					3
GARAGES & CARPORTS					6,500
EXTRA FEATURES					9,500
SUBTOTAL					130,050
GRADE FACTOR					85 %
UNADJUSTED VALUE					110,540
FACTOR					100 %

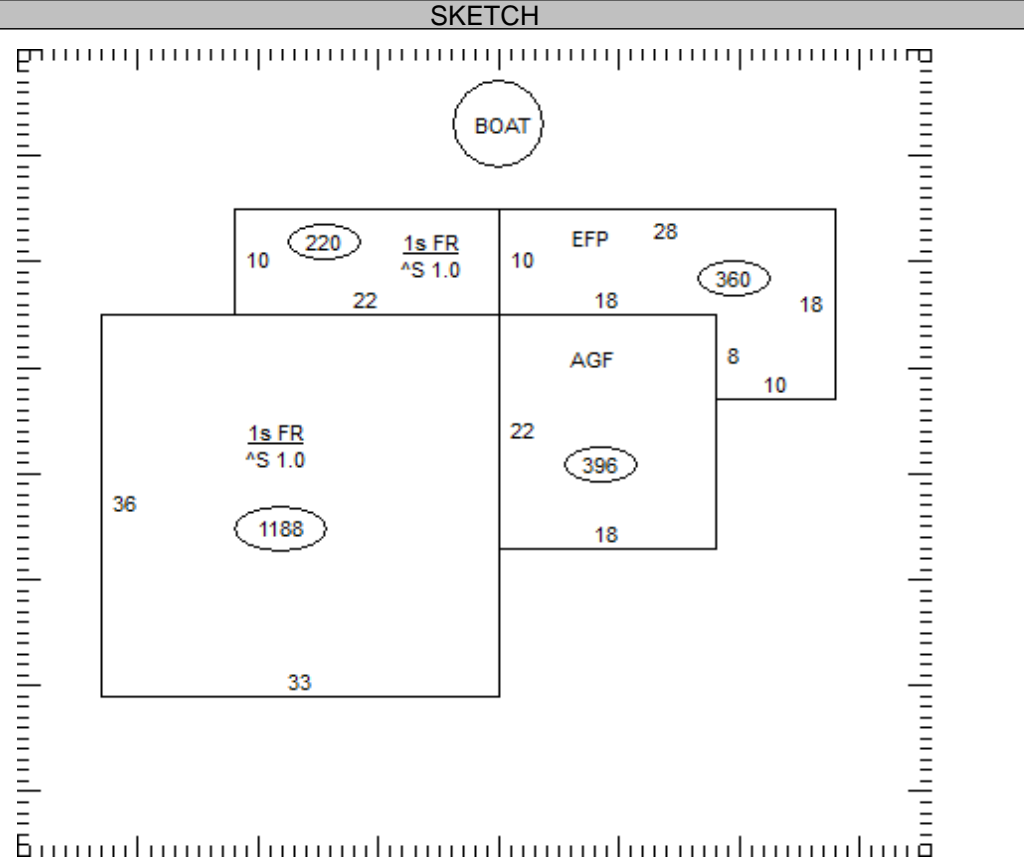

OCCUPANCY	ST.HT	SIZE	AREA	GRADE	PRICE	AGE	REMD	CND	UNADJ VAL	PHYS	PHYS VAL	FUNC	TRUE VAL
DWELLING	1	SK	1,408	D+		1959	1990	A	110,540	40	66,320		67,000
1 Boat House	10	24x27	648	C	6.00	2000		A	3,890	29	2,760		2,800
2													
3													
4													
5													
6													
7													
8													
9													
10													
11													

09-023500.0000

TOTAL 69,800

COMMENTS

Dwelling has an Economic Factor of 101%