



09-000200.0117

PROP. CLASS

5 | 1 | 0

NEIGHBORHOOD

095CL90-CL90

M 04

B

C 151

MCCLURE LARRY J & JUDITH L
 MCCLURE LARRY J & JUDITH L
 5519 HIDDEN SHORES DR
 CELINA, OH 45822

LEGAL INFORMATION
 HIDDEN SHORES SEC 1

LOT#: 17

	OWNERSHIP	ADDRESS	CITY	STATE	ZIP	DATE	AMOUNT	DEED:CONV#	JS	VALID
1	MCCLURE LARRY J & JUDITH L	5519 HIDDEN SHORES DR	CELINA	OH	45822	03/19/2019	263,000	WDC : 168	<input type="checkbox"/>	<input checked="" type="checkbox"/>
2	KUETERMAN THOMAS P	5519 E HIDDEN SHORES DR	CELINA	OH	45822	05/01/2017	255,000	WDC : 267	<input type="checkbox"/>	<input checked="" type="checkbox"/>
3	CORNYN MARY A 2006 Bennington 23' pontoon as well as fully furnished included in the sale price.	5519 E HIDDEN SHORES DR	CELINA	OH	45822	03/16/2012	210,000	WDC : A : 124	<input type="checkbox"/>	<input type="checkbox"/>

X: TTO LISTER: DA DATE: 04/25/2005 TIME: 12:00:00 AM LETTER LETTER REC'D GIS CODE

STREET/ROAD	TOPOGRAPHY	PU-UTILITIES-PR	NEIGHBORHOOD	INFLUENCE FACTORS	PROPERTY LOCATION	
<input checked="" type="checkbox"/> PAVED <input type="checkbox"/> GRAVEL <input type="checkbox"/> DIRT <input type="checkbox"/> SIDEWALKS <input type="checkbox"/> CURBS	<input checked="" type="checkbox"/> LEVEL <input type="checkbox"/> HIGH <input type="checkbox"/> LOW <input type="checkbox"/> ROLLING <input type="checkbox"/> STANDARD	<input type="checkbox"/> WATER <input type="checkbox"/> SEWER <input type="checkbox"/> GAS <input type="checkbox"/> ELECTRIC <input checked="" type="checkbox"/> STANDARD	<input checked="" type="checkbox"/> IMPROVING <input type="checkbox"/> STATIC <input type="checkbox"/> DECLINING <input type="checkbox"/> OLD <input type="checkbox"/> STANDARD	<input type="checkbox"/> A. NO ROAD <input type="checkbox"/> B. TOPGRHY <input type="checkbox"/> C. Ex Front <input type="checkbox"/> D. QUANTITY <input type="checkbox"/> E. SZ/SHAPE	<input type="checkbox"/> F. RESTRICT <input type="checkbox"/> G. WOOD LT <input type="checkbox"/> H. VACANCY <input type="checkbox"/> I. WATER FRONT <input type="checkbox"/> J. OTHER/CDU	5519 E HIDDEN SHORES DR, COMMENT TY2018:Net Gen=\$3,528.48, Other Assessment=\$0.00 DE11 CORR COND DE14 CORR PLMBING

LAND COMPUTATIONS

LAND TYPE	SIZE	M	RATE	C	INF	M	VALUE	C
F:Front	F85 D90	ST900	DP77	ADJ693		58,900	0	
TOTAL						58,900	0	

VALUATION SUMMARY

VALUE YEAR	2017	2015	2014	2011				
REASON FOR CHANGE	RAPP	NC	RAPP	RAPP				
APPRaised VALUE	LAND	58,900	58,900	58,900	58,900			
	IMPR	170,600	158,700	151,600	151,600			
	TOTAL	229,500	217,600	210,500	210,500			
ASSESSED VALUE	LAND	20,620	20,620	20,620	20,620			
	IMPR	59,710	55,550	53,060	53,060			
	TOTAL	80,330	76,170	73,680	73,680			

OCCUPANCY	EXTERIOR	FLOOR	AREA	CONST	VALUE
<input checked="" type="checkbox"/> SNGL FMLY	<input type="checkbox"/> WOOD	1	1345	FR	109,120
<input type="checkbox"/> DUPLEX	<input type="checkbox"/> STUCCO	.5	409	FR	24,220
<input type="checkbox"/> TRIPLEX	<input checked="" type="checkbox"/> ALM/VYNL				
<input type="checkbox"/> CONVR	<input type="checkbox"/> CONC BLK				
<input type="checkbox"/> MOBILE HM	<input type="checkbox"/> METAL				
<input type="checkbox"/> BI/L TRI/L	<input checked="" type="checkbox"/> BRICK				
<input type="checkbox"/> MOD/MAN	<input type="checkbox"/> STONE				

ROOFING	ROOF TYPE
<input type="checkbox"/> METAL	<input type="checkbox"/> GABLE
<input type="checkbox"/> SLT/TLE	<input checked="" type="checkbox"/> HIP
<input checked="" type="checkbox"/> SHINGLES	<input type="checkbox"/> GAMBREL
<input type="checkbox"/> SHAKES	<input type="checkbox"/> MANSARD
<input type="checkbox"/> COMPOSITE	<input type="checkbox"/> FLAT

FLOORS	B	1	2	3	U		VALUE
CONCRETE	<input type="checkbox"/>	<input type="checkbox"/>	<input type="checkbox"/>	<input type="checkbox"/>	<input type="checkbox"/>	MULTI-FAMILY #	0
WOOD	<input type="checkbox"/>	<input type="checkbox"/>	<input type="checkbox"/>	<input type="checkbox"/>	<input type="checkbox"/>	BSMT FINISH	0 S.F.
TILE/COMPO	<input type="checkbox"/>	<input checked="" type="checkbox"/>	<input type="checkbox"/>	<input type="checkbox"/>	<input type="checkbox"/>	FIREPLACE #	1
CARPET	<input type="checkbox"/>	<input checked="" type="checkbox"/>	<input checked="" type="checkbox"/>	<input type="checkbox"/>	<input type="checkbox"/>	HEATING	0 S.F.
						AIR COND	1,754 S.F.
						PLUMBING #	5
						GARAGES & CARPORTS	7,300
						EXTRA FEATURES	4,100
						SUBTOTAL	156,870
						GRADE FACTOR	125 %
						UNADJUSTED VALUE	196,090
						FACTOR	100 %

OCCUPANCY	ST.HT	SIZE	AREA	GRADE	PRICE	AGE	REMD	CND	UNADJ VAL	PHYS	PHYS VAL	FUNC	TRUE VAL
DWELLING	1.5	SK	1,754	B+		2002		A	196,090	13	170,600		170,600
1													
2													
3													
4													
5													
6													
7													
8													
9													
10													
11													

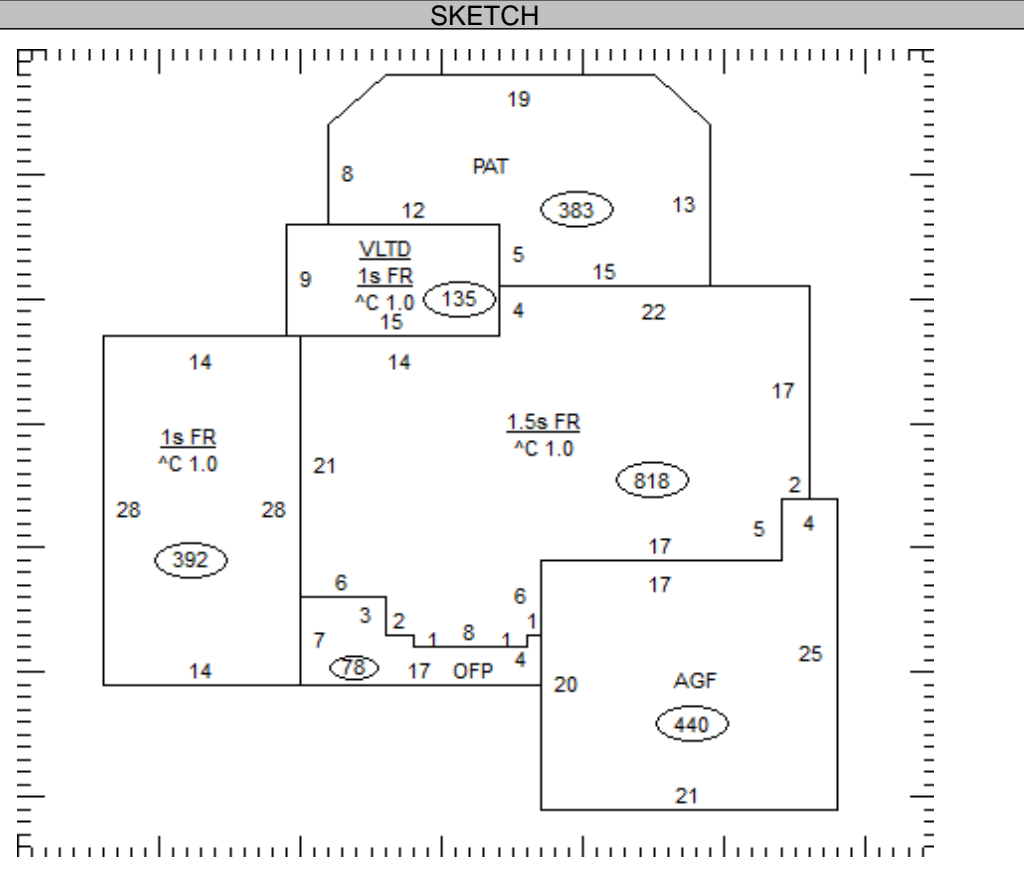

09-000200.0117	TOTAL	170,600
----------------	--------------	---------

COMMENTS

Dwelling has an Economic Factor of 100%

2 OF 2		
PROP. CLASS		
5	1	0
NEIGHBORHOOD		
095CL90-CL90		
M	04	
B		
C	151	

09-000200.0117

MCCLURE LARRY J & JUDITH L
 MCCLURE LARRY J & JUDITH L
 5519 HIDDEN SHORES DR
 CELINA, OH 45822

LEGAL INFORMATION
 HIDDEN SHORES SEC 1

LOT#: 17

	OWNERSHIP	ADDRESS	CITY	STATE	ZIP	DATE	AMOUNT	DEED:CONV#	JS	VALID
1	BAUER JOETTA TRUSTEE	5170 PARKSIDE DR	MASON	OH	45040	03/30/2010	0	QCE : X : 0	<input type="checkbox"/>	<input type="checkbox"/>
2	BAUER RAYMOND L & JOETTA	5170 PARKSIDE DR	MASON	OH	45040	06/18/2008	0	QCE : X : 0	<input type="checkbox"/>	<input type="checkbox"/>
3	BAUER RAYMOND L & JOETTA	5170 PARKSIDE DR	MASON	OH	45040	03/31/2003	285,000	: A : 0	<input type="checkbox"/>	<input checked="" type="checkbox"/>

X: TTO LISTER: DA DATE: 04/25/2005 TIME: 12:00:00 AM LETTER LETTER REC'D GIS CODE

STREET/ROAD	TOPOGRAPHY	PU-UTILITIES-PR	NEIGHBORHOOD	INFLUENCE FACTORS				PROPERTY LOCATION
<input checked="" type="checkbox"/> PAVED	<input checked="" type="checkbox"/> LEVEL	<input type="checkbox"/> WATER <input type="checkbox"/>	<input checked="" type="checkbox"/> IMPROVING	<input type="checkbox"/> A. NO ROAD	<input type="checkbox"/> F. RESTRICT	5519 E HIDDEN SHORES DR,		
<input type="checkbox"/> GRAVEL	<input type="checkbox"/> HIGH	<input type="checkbox"/> SEWER <input type="checkbox"/>	<input type="checkbox"/> STATIC	<input type="checkbox"/> B. TOPGRHY	<input type="checkbox"/> G. WOOD LT	COMMENT		
<input type="checkbox"/> DIRT	<input type="checkbox"/> LOW	<input type="checkbox"/> GAS <input type="checkbox"/>	<input type="checkbox"/> DECLINING	<input type="checkbox"/> C. Ex Front	<input type="checkbox"/> H. VACANCY			
<input type="checkbox"/> SIDEWALKS	<input type="checkbox"/> ROLLING	<input type="checkbox"/> ELECTRIC <input type="checkbox"/>	<input type="checkbox"/> OLD	<input type="checkbox"/> D. QUANTITY	<input type="checkbox"/> I. WATER FRONT			
<input type="checkbox"/> CURBS	<input type="checkbox"/> STANDARD	<input checked="" type="checkbox"/> STANDARD	<input type="checkbox"/> STANDARD	<input type="checkbox"/> E. SZ/SHAPE	<input type="checkbox"/> J. OTHER/CDU			

LAND COMPUTATIONS

LAND TYPE	SIZE	M	RATE	C	INF	M	VALUE	C
TOTAL							58,900	0

VALUATION SUMMARY

VALUE YEAR	REASON FOR CHANGE	APPRaised	LAND	IMPR	TOTAL	ASSESSED	LAND	IMPR	TOTAL

OCCUPANCY	EXTERIOR	FLOOR	AREA	CONST	VALUE
<input type="checkbox"/> SNGL FMLY	<input type="checkbox"/> WOOD				
<input type="checkbox"/> DUPLEX	<input type="checkbox"/> STUCCO				
<input type="checkbox"/> TRIPLEX	<input type="checkbox"/> ALM/VYNL				
<input type="checkbox"/> CONVR	<input type="checkbox"/> CONC BLK				
<input type="checkbox"/> MOBILE HM	<input type="checkbox"/> METAL				
<input type="checkbox"/> BI/L TRI/L	<input type="checkbox"/> BRICK				
<input type="checkbox"/> MOD/MAN	<input type="checkbox"/> STONE				

ROOFING	ROOF TYPE
<input type="checkbox"/> METAL	<input type="checkbox"/> GABLE
<input type="checkbox"/> SLT/TLE	<input type="checkbox"/> HIP
<input type="checkbox"/> SHINGLES	<input type="checkbox"/> GAMBREL
<input type="checkbox"/> SHAKES	<input type="checkbox"/> MANSARD
<input type="checkbox"/> COMPOSITE	<input type="checkbox"/> FLAT

FLOORS	B	1	2	3	U		VALUE
CONCRETE	<input type="checkbox"/>	<input type="checkbox"/>	<input type="checkbox"/>	<input type="checkbox"/>	<input type="checkbox"/>	MULTI-FAMILY #	0
WOOD	<input type="checkbox"/>	<input type="checkbox"/>	<input type="checkbox"/>	<input type="checkbox"/>	<input type="checkbox"/>	BSMT FINISH	0 S.F.
TILE/COMPO	<input type="checkbox"/>	<input type="checkbox"/>	<input type="checkbox"/>	<input type="checkbox"/>	<input type="checkbox"/>	FIREPLACE #	0
CARPET	<input type="checkbox"/>	<input type="checkbox"/>	<input type="checkbox"/>	<input type="checkbox"/>	<input type="checkbox"/>	HEATING	0 S.F.
						AIR COND	0 S.F.
						PLUMBING #	0
						GARAGES & CARPORTS	0
						EXTRA FEATURES	0
						SUBTOTAL	0
						GRADE FACTOR	%
						UNADJUSTED VALUE	0
						FACTOR	%

ACCOMMODATIONS	B	1	2	3	U		VALUE
# OF ROOMS							
BEDROOMS							
FIREPLACES							
HEAT & AC							
NO HEAT	<input type="checkbox"/>	<input type="checkbox"/>	<input type="checkbox"/>	<input type="checkbox"/>	<input type="checkbox"/>		
CTRL HEAT	<input type="checkbox"/>	<input type="checkbox"/>	<input type="checkbox"/>	<input type="checkbox"/>	<input type="checkbox"/>		
HW/STEAM	<input type="checkbox"/>	<input type="checkbox"/>	<input type="checkbox"/>	<input type="checkbox"/>	<input type="checkbox"/>		
ELECTRIC	<input type="checkbox"/>	<input type="checkbox"/>	<input type="checkbox"/>	<input type="checkbox"/>	<input type="checkbox"/>		
HEAT PUMP	<input type="checkbox"/>	<input type="checkbox"/>	<input type="checkbox"/>	<input type="checkbox"/>	<input type="checkbox"/>		
FLR/WALL	<input type="checkbox"/>	<input type="checkbox"/>	<input type="checkbox"/>	<input type="checkbox"/>	<input type="checkbox"/>		
STVE/SPCE	<input type="checkbox"/>	<input type="checkbox"/>	<input type="checkbox"/>	<input type="checkbox"/>	<input type="checkbox"/>		
GEO THERMAL	<input type="checkbox"/>	<input type="checkbox"/>	<input type="checkbox"/>	<input type="checkbox"/>	<input type="checkbox"/>		
OUTSIDE	<input type="checkbox"/>	<input type="checkbox"/>	<input type="checkbox"/>	<input type="checkbox"/>	<input type="checkbox"/>		
CTRL A/C	<input type="checkbox"/>	<input type="checkbox"/>	<input type="checkbox"/>	<input type="checkbox"/>	<input type="checkbox"/>		
PLUMBING						BASE	<input type="checkbox"/>
X FULL BATH							
X HALF BATH							
X FIXTURES							

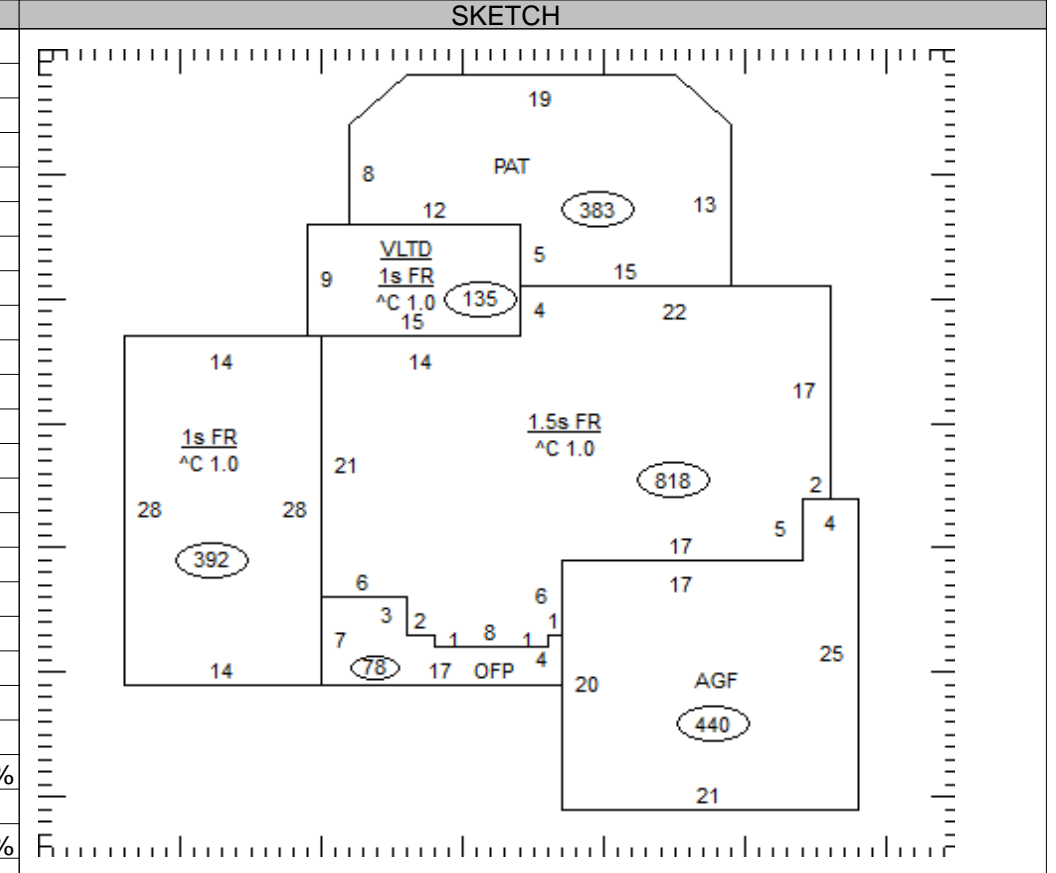

OCCUPANCY	ST.HT	SIZE	AREA	GRADE	PRICE	AGE	REMD	CND	UNADJ VAL	PHYS	PHYS VAL	FUNC	TRUE VAL
DWELLING		SK											
1													
2													
3													
4													
5													
6													
7													
8													
9													
10													
11													

TOTAL	0
-------	---

COMMENTS

09-000200.0117