

1 OF 1		
PROP. CLASS		
5	1	0
NEIGHBORHOOD		
000509-TS70		
M	14A2	
B		
C	17	

05-192800.0000

CERVANTES ANA I
CERVANTES ANA I
901 EDGEWOOD DR
COLDWATER, OH 45828

LEGAL INFORMATION
EASTVIEW FOURTH ADDITION

LOT#: 1539

	OWNERSHIP	ADDRESS	CITY	STATE	ZIP	DATE	AMOUNT	DEED:CONV#	JS	VALID
1	CERVANTES ANA I	901 EDGEWOOD DR	COLDWATER	OH	45828	04/01/2016	309,900	WDC : 194	<input type="checkbox"/>	<input checked="" type="checkbox"/>
2	HOLLENBACHER MARK A &	901 EDGEWOOD DR	COLDWATER	OH	45828	02/27/2006	0	QCE : X : 0	<input type="checkbox"/>	<input type="checkbox"/>
3	HOLLENBACHER MARK A &	709 1/2 LILAC DR	COLDWATER	OH	45828	07/18/2003	25,500	: A : 0	<input type="checkbox"/>	<input checked="" type="checkbox"/>

X: TTO LISTER: NS DATE: 02/22/2005 TIME: 12:00:00 AM LETTER LETTER REC'D GIS CODE

STREET/ROAD	TOPOGRAPHY	PU-UTILITIES-PR	NEIGHBORHOOD	INFLUENCE FACTORS		PROPERTY LOCATION
<input checked="" type="checkbox"/> PAVED	<input checked="" type="checkbox"/> LEVEL	<input type="checkbox"/> WATER <input type="checkbox"/>	<input type="checkbox"/> IMPROVING	<input type="checkbox"/> A. NO ROAD	<input type="checkbox"/> F. RESTRICT	901 EDGEWOOD DR,
<input type="checkbox"/> GRAVEL	<input type="checkbox"/> HIGH	<input type="checkbox"/> SEWER <input type="checkbox"/>	<input type="checkbox"/> STATIC	<input type="checkbox"/> B. TOPGRHY	<input type="checkbox"/> G. WOOD LT	COMMENT
<input type="checkbox"/> DIRT	<input type="checkbox"/> LOW	<input type="checkbox"/> GAS <input type="checkbox"/>	<input type="checkbox"/> DECLINING	<input type="checkbox"/> C. Ex Front	<input type="checkbox"/> H. VACANCY	TY2018:Net Gen=\$3,597.32, Other Assessment=\$0.00
<input checked="" type="checkbox"/> SIDEWALKS	<input type="checkbox"/> ROLLING	<input type="checkbox"/> ELECTRIC <input type="checkbox"/>	<input type="checkbox"/> OLD	<input type="checkbox"/> D. QUANTITY	<input type="checkbox"/> I. WATER FRONT	DE17 RMV OWN OCC/DIDN'T RET APP
<input type="checkbox"/> CURBS	<input type="checkbox"/> STANDARD	<input checked="" type="checkbox"/> STANDARD	<input checked="" type="checkbox"/> STANDARD	<input type="checkbox"/> E. SZ/SHAPE	<input type="checkbox"/> J. OTHER/CDU	

LAND COMPUTATIONS

LAND TYPE	SIZE	M	RATE	C	INF	M	VALUE	C
F:Front	F112 D131	ST375	DP93	ADJ349			39,100	0
					TOTAL		39,100	0

VALUATION SUMMARY

VALUE YEAR	2017	2014	2011				
REASON FOR CHANGE	RAPP	RAPP	RAPP				
APPRAISED	<u>LAND</u>	39,100	34,400	34,400			
VALUE	<u>IMPR</u>	239,000	207,700	207,700			
	<u>TOTAL</u>	278,100	242,100	242,100			
ASSESSED	<u>LAND</u>	13,690	12,040	12,040			
VALUE	<u>IMPR</u>	83,650	72,700	72,700			
	<u>TOTAL</u>	97,340	84,740	84,740			

OCCUPANCY	EXTERIOR
<input checked="" type="checkbox"/> SNGL FMLY	<input type="checkbox"/> WOOD
<input type="checkbox"/> DUPLEX	<input type="checkbox"/> STUCCO
<input type="checkbox"/> TRIPLEX	<input checked="" type="checkbox"/> ALM/VYNL
<input type="checkbox"/> CONVR	<input type="checkbox"/> CONC BLK
<input type="checkbox"/> MOBILE HM	<input type="checkbox"/> METAL
<input type="checkbox"/> BI/L TRI/L	<input type="checkbox"/> BRICK
<input type="checkbox"/> MOD/MAN	<input type="checkbox"/> STONE

ROOFING	ROOF TYPE
<input type="checkbox"/> METAL	<input type="checkbox"/> GABLE
<input type="checkbox"/> SLT/TLE	<input checked="" type="checkbox"/> HIP
<input checked="" type="checkbox"/> SHINGLES	<input type="checkbox"/> GAMBREL
<input type="checkbox"/> SHAKES	<input type="checkbox"/> MANSARD
<input type="checkbox"/> COMPOSITE	<input type="checkbox"/> FLAT

FLOORS	B	1	2	3	U
CONCRETE	<input type="checkbox"/>	<input type="checkbox"/>	<input type="checkbox"/>	<input type="checkbox"/>	<input type="checkbox"/>
WOOD	<input type="checkbox"/>	<input type="checkbox"/>	<input type="checkbox"/>	<input type="checkbox"/>	<input type="checkbox"/>
TILE/COMPO	<input type="checkbox"/>	<input checked="" type="checkbox"/>	<input type="checkbox"/>	<input type="checkbox"/>	<input type="checkbox"/>
CARPET	<input type="checkbox"/>	<input checked="" type="checkbox"/>	<input type="checkbox"/>	<input type="checkbox"/>	<input type="checkbox"/>

INT. FINISH	B	1	2	3	U
PLASTER/DW	<input type="checkbox"/>	<input checked="" type="checkbox"/>	<input type="checkbox"/>	<input type="checkbox"/>	<input type="checkbox"/>
PANELING	<input type="checkbox"/>	<input type="checkbox"/>	<input type="checkbox"/>	<input type="checkbox"/>	<input type="checkbox"/>
UNFINISHED	<input checked="" type="checkbox"/>	<input type="checkbox"/>	<input type="checkbox"/>	<input type="checkbox"/>	<input type="checkbox"/>

ACCOMMODATIONS					
# OF ROOMS		6			
BEDROOMS		3			
FIREPLACES		1			
HEAT & AC	B	1	2	3	U

NO HEAT	<input type="checkbox"/>	<input type="checkbox"/>	<input type="checkbox"/>	<input type="checkbox"/>	<input type="checkbox"/>
CTRL HEAT	<input type="checkbox"/>	<input checked="" type="checkbox"/>	<input type="checkbox"/>	<input type="checkbox"/>	<input type="checkbox"/>
HW/STEAM	<input type="checkbox"/>	<input type="checkbox"/>	<input type="checkbox"/>	<input type="checkbox"/>	<input type="checkbox"/>
ELECTRIC	<input type="checkbox"/>	<input type="checkbox"/>	<input type="checkbox"/>	<input type="checkbox"/>	<input type="checkbox"/>
HEAT PUMP	<input type="checkbox"/>	<input type="checkbox"/>	<input type="checkbox"/>	<input type="checkbox"/>	<input type="checkbox"/>
FLR/WALL	<input type="checkbox"/>	<input type="checkbox"/>	<input type="checkbox"/>	<input type="checkbox"/>	<input type="checkbox"/>
STVE/SPCE	<input type="checkbox"/>	<input type="checkbox"/>	<input type="checkbox"/>	<input type="checkbox"/>	<input type="checkbox"/>
GEOHERMAL	<input type="checkbox"/>	<input type="checkbox"/>	<input type="checkbox"/>	<input type="checkbox"/>	<input type="checkbox"/>
OUTSIDE	<input type="checkbox"/>	<input type="checkbox"/>	<input type="checkbox"/>	<input type="checkbox"/>	<input type="checkbox"/>
CTRL A/C	<input type="checkbox"/>	<input checked="" type="checkbox"/>	<input type="checkbox"/>	<input type="checkbox"/>	<input type="checkbox"/>

PLUMBING	BASE				
X FULL BATH		1			
X HALF BATH		1			
X FIXTURES					

FLOOR	AREA	CONST	VALUE
1	2206	FR	148,490
BSMT	2206		28,680
SUBTOTAL			177,170
MULTI-FAMILY #	0		0
BSMT FINISH	0 S.F.		0
FIREPLACE #	1		4,000
HEATING	0 S.F.		0
AIR COND	2,206 S.F.		3,310
PLUMBING #	5		5,500
GARAGES & CARPORTS			14,100
EXTRA FEATURES			8,200
SUBTOTAL			212,280
GRADE FACTOR			115 %
UNADJUSTED VALUE			244,120
FACTOR			%

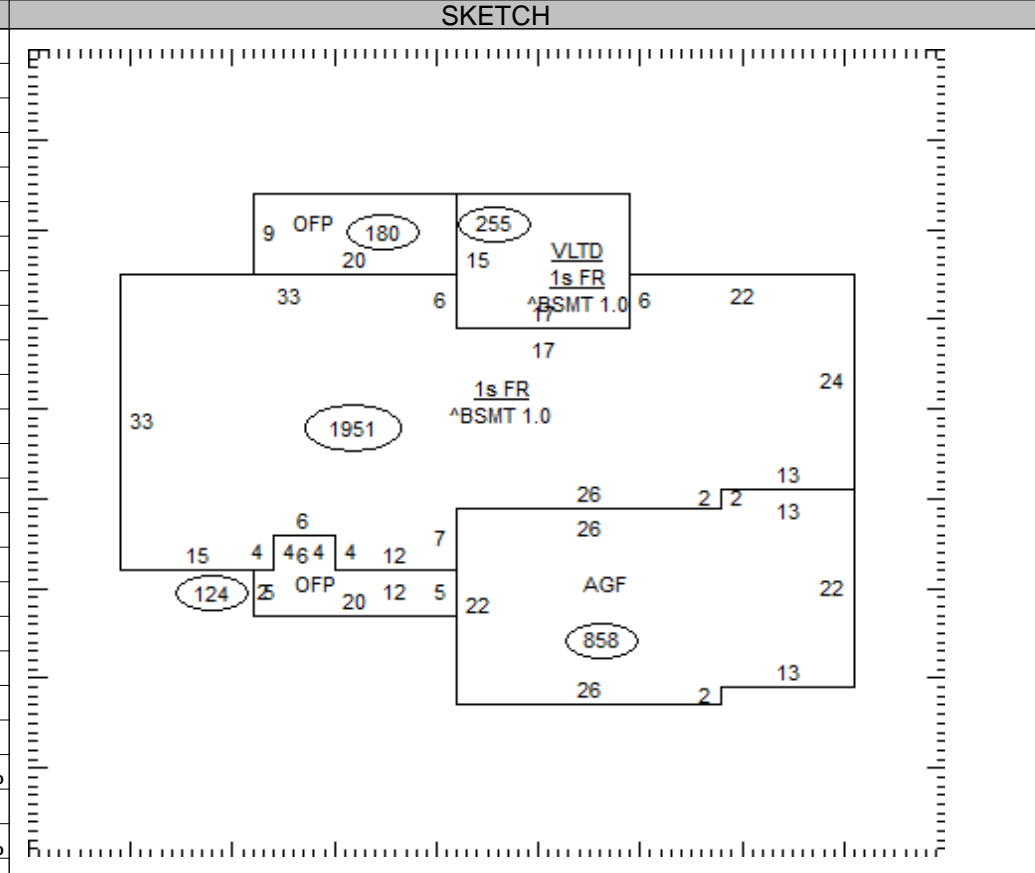

OCCUPANCY	ST.HT	SIZE	AREA	GRADE	PRICE	AGE	REMD	CND	UNADJ VAL	PHYS	PHYS VAL	FUNC	TRUE VAL
DWELLING	1	SK	2,206	B-		2004		A	244,120	11	217,270		239,000
1													
2													
3													
4													
5													
6													
7													
8													
9													
10													
11													

05-192800.0000 TOTAL 239,000

COMMENTS

50 LINEAL FEET BRICK TRIM 8FT HIGH
 Dwelling has an Economic Factor of 110%