



05-162200.0000

EVERMAN SCOTT A & LAIRD ROBYN M
 EVERMAN SCOTT A & LAIRD ROBYN M
 912 W BUTLER ST
 COLDWATER, OH 45828

BUTLER TWP-COLDWATER CORP / COLDWATER SD
 08-28-304-005

LEGAL INFORMATION
 OAKWOOD FIRST ADD.

LOT#: 1214

1 OF 1		
PROP. CLASS		
5	1	0
NEIGHBORHOOD		
000509-TS70		
M	14B2	
B		
C	82	

	OWNERSHIP	ADDRESS	CITY	STATE	ZIP	DATE	AMOUNT	DEED:CONV#	JS	VALID
1	EVERMAN SCOTT A & LAIRD	912 W BUTLER ST	COLDWATER	OH	45828	02/12/2016	164,000	WDC : 81	<input type="checkbox"/>	<input checked="" type="checkbox"/>
2	STELZER THOMAS J &	912 W BUTLER ST	COLDWATER	OH	45828	03/25/1991	85,000	: A : 0	<input type="checkbox"/>	<input checked="" type="checkbox"/>
3							0	0	<input type="checkbox"/>	<input type="checkbox"/>

X: TTO LISTER: NS DATE: 12/29/2004 TIME: 12:00:00 AM LETTER LETTER REC'D GIS CODE

STREET/ROAD	TOPOGRAPHY	PU-UTILITIES-PR	NEIGHBORHOOD	INFLUENCE FACTORS				PROPERTY LOCATION
<input checked="" type="checkbox"/> PAVED <input type="checkbox"/> GRAVEL <input type="checkbox"/> DIRT <input checked="" type="checkbox"/> SIDEWALKS <input type="checkbox"/> CURBS	<input checked="" type="checkbox"/> LEVEL <input type="checkbox"/> HIGH <input type="checkbox"/> LOW <input type="checkbox"/> ROLLING <input type="checkbox"/> STANDARD	<input type="checkbox"/> WATER <input type="checkbox"/> SEWER <input type="checkbox"/> GAS <input type="checkbox"/> ELECTRIC <input checked="" type="checkbox"/> STANDARD	<input type="checkbox"/> IMPROVING <input type="checkbox"/> STATIC <input type="checkbox"/> DECLINING <input type="checkbox"/> OLD <input checked="" type="checkbox"/> STANDARD	<input type="checkbox"/> A. NO ROAD <input type="checkbox"/> B. TOPGRHY <input type="checkbox"/> C. Ex Front <input type="checkbox"/> D. QUANTITY <input type="checkbox"/> E. SZ/SHAPE	<input type="checkbox"/> F. RESTRICT <input type="checkbox"/> G. WOOD LT <input type="checkbox"/> H. VACANCY <input type="checkbox"/> I. WATER FRONT <input type="checkbox"/> J. OTHER/CDU	912 BUTLER ST, COLDWATER		
COMMENT								
TY2018:Net Gen=\$2,323.20, Other Assessment=\$0.00								

LAND COMPUTATIONS								
LAND TYPE	SIZE	M	RATE	C	INF	M VALUE	C	
F:Front	F100 D115	ST375	DP87	ADJ326		32,600	0	
TOTAL							32,600	0

VALUATION SUMMARY

VALUE YEAR	2017	2014	2011			
REASON FOR CHANGE	RAPP	RAPP	RAPP			
APPRaised	32,600	28,700	28,700			
VALUE	151,800	124,800	124,800			
	<u>TOTAL</u>	<u>153,500</u>	<u>153,500</u>			
ASSESSed	11,410	10,050	10,050			
VALUE	53,130	43,680	43,680			
	<u>TOTAL</u>	<u>53,730</u>	<u>53,730</u>			

OCCUPANCY	EXTERIOR
<input checked="" type="checkbox"/> SNGL FMLY <input type="checkbox"/> DUPLEX <input type="checkbox"/> TRIPLEX <input type="checkbox"/> CONVR <input type="checkbox"/> MOBILE HM <input type="checkbox"/> BI/L TRI/L <input type="checkbox"/> MOD/MAN	<input type="checkbox"/> WOOD <input type="checkbox"/> STUCCO <input type="checkbox"/> ALM/VYNL <input type="checkbox"/> CONC BLK <input type="checkbox"/> METAL <input checked="" type="checkbox"/> BRICK <input type="checkbox"/> STONE

ROOFING	ROOF TYPE
<input type="checkbox"/> METAL <input type="checkbox"/> SLT/TLE <input checked="" type="checkbox"/> SHINGLES <input type="checkbox"/> SHAKES <input type="checkbox"/> COMPOSITE	<input checked="" type="checkbox"/> GABLE <input type="checkbox"/> HIP <input type="checkbox"/> GAMBREL <input type="checkbox"/> MANSARD <input type="checkbox"/> FLAT

FLOORS	B	1	2	3	U
CONCRETE	<input checked="" type="checkbox"/>	<input type="checkbox"/>	<input type="checkbox"/>	<input type="checkbox"/>	<input type="checkbox"/>
WOOD	<input type="checkbox"/>	<input checked="" type="checkbox"/>	<input type="checkbox"/>	<input type="checkbox"/>	<input type="checkbox"/>
TILE/COMPO	<input type="checkbox"/>	<input type="checkbox"/>	<input type="checkbox"/>	<input type="checkbox"/>	<input type="checkbox"/>
CARPET	<input type="checkbox"/>	<input checked="" type="checkbox"/>	<input type="checkbox"/>	<input type="checkbox"/>	<input type="checkbox"/>

INT. FINISH	B	1	2	3	U
PLASTER/DW	<input type="checkbox"/>	<input checked="" type="checkbox"/>	<input type="checkbox"/>	<input type="checkbox"/>	<input type="checkbox"/>
PANELING	<input type="checkbox"/>	<input type="checkbox"/>	<input type="checkbox"/>	<input type="checkbox"/>	<input type="checkbox"/>
UNFINISHED	<input checked="" type="checkbox"/>	<input type="checkbox"/>	<input type="checkbox"/>	<input type="checkbox"/>	<input type="checkbox"/>

ACCOMMODATIONS					
# OF ROOMS		5			
BEDROOMS		3			
FIREPLACES		1			

HEAT & AC	B	1	2	3	U
NO HEAT	<input type="checkbox"/>	<input type="checkbox"/>	<input type="checkbox"/>	<input type="checkbox"/>	<input type="checkbox"/>
CTRL HEAT	<input type="checkbox"/>	<input checked="" type="checkbox"/>	<input type="checkbox"/>	<input type="checkbox"/>	<input type="checkbox"/>
HW/STEAM	<input type="checkbox"/>	<input type="checkbox"/>	<input type="checkbox"/>	<input type="checkbox"/>	<input type="checkbox"/>
ELECTRIC	<input type="checkbox"/>	<input type="checkbox"/>	<input type="checkbox"/>	<input type="checkbox"/>	<input type="checkbox"/>
HEAT PUMP	<input type="checkbox"/>	<input type="checkbox"/>	<input type="checkbox"/>	<input type="checkbox"/>	<input type="checkbox"/>
FLR/WALL	<input type="checkbox"/>	<input type="checkbox"/>	<input type="checkbox"/>	<input type="checkbox"/>	<input type="checkbox"/>
STVE/SPCE	<input type="checkbox"/>	<input type="checkbox"/>	<input type="checkbox"/>	<input type="checkbox"/>	<input type="checkbox"/>
GEOHERMAL	<input type="checkbox"/>	<input type="checkbox"/>	<input type="checkbox"/>	<input type="checkbox"/>	<input type="checkbox"/>
OUTSIDE	<input type="checkbox"/>	<input type="checkbox"/>	<input type="checkbox"/>	<input type="checkbox"/>	<input type="checkbox"/>
CTRL A/C	<input type="checkbox"/>	<input checked="" type="checkbox"/>	<input type="checkbox"/>	<input type="checkbox"/>	<input type="checkbox"/>

PLUMBING	BASE
X FULL BATH	<input checked="" type="checkbox"/>
X HALF BATH	<input type="checkbox"/>
X FIXTURES	<input type="checkbox"/>

FLOOR	AREA	CONST	VALUE
1	1883	BRK	144,370
BSMT	1283		16,680
SUBTOTAL			161,050
MULTI-FAMILY #	0		0
BSMT FINISH	0 S.F.		0
FIREPLACE #	1		4,000
HEATING	0 S.F.		0
AIR COND	1,283 S.F.		1,920
PLUMBING #	3		3,300
GARAGES & CARPORTS			9,500
EXTRA FEATURES			2,800
SUBTOTAL			182,570
GRADE FACTOR			105 %
UNADJUSTED VALUE			191,700
FACTOR			100 %

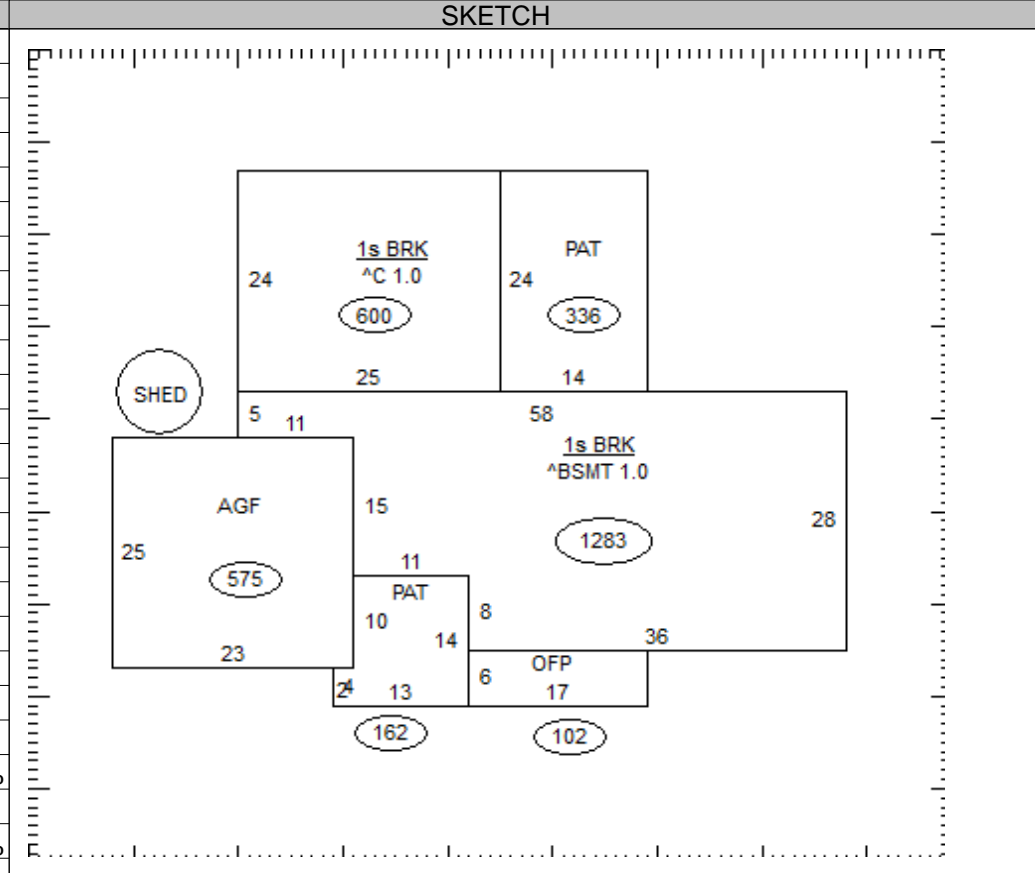

OCCUPANCY	ST.HT	SIZE	AREA	GRADE	PRICE	AGE	REMD	CND	UNADJ VAL	PHYS	PHYS VAL	FUNC	TRUE VAL
DWELLING	1	SK	1,883	C+		1981		A	191,700	28	138,020		151,800
1 Shed		0x0		C		1990		A		47			0
2													
3													
4													
5													
6													
7													
8													
9													
10													
11													

05-162200.0000	TOTAL	151,800
----------------	--------------	---------

COMMENTS

Dwelling has an Economic Factor of 110%