

1 OF 1		
PROP. CLASS		
5	1	0
NEIGHBORHOOD		
000506-TS50		
M	14B8	
B		
C	35	

05-104600.0000

GIERE MITCHELL R
GIERE MITCHELL R
600 N MILL ST
COLDWATER, OH 45828

LEGAL INFORMATION
SELHORST THIRD ADDITION

LOT#: 658

	OWNERSHIP	ADDRESS	CITY	STATE	ZIP	DATE	AMOUNT	DEED:CONV#	JS	VALID
1	GIERE MITCHELL R	600 N MILL ST	COLDWATER	OH	45828	11/13/2017	154,900	WDC : 772	<input type="checkbox"/>	<input checked="" type="checkbox"/>
2	AHRENS DUSTIN W	600 MILL ST	COLDWATER	OH	45828	04/01/2009	99,000	WDC : A : 165	<input type="checkbox"/>	<input checked="" type="checkbox"/>
3	MUELLER VIOLA A	403 PARK ST	COLDWATER	OH	45828	07/18/1989	0	: X : 0	<input type="checkbox"/>	<input type="checkbox"/>

X: TTO LISTER: NS DATE: 01/20/2005 TIME: 12:00:00 AM LETTER LETTER REC'D GIS CODE

STREET/ROAD	TOPOGRAPHY	PU-UTILITIES-PR	NEIGHBORHOOD	INFLUENCE FACTORS	PROPERTY LOCATION
<input checked="" type="checkbox"/> PAVED	<input checked="" type="checkbox"/> LEVEL	<input type="checkbox"/> WATER	<input type="checkbox"/> IMPROVING	<input type="checkbox"/> A. NO ROAD	600 N MILL ST, COLDWATER
<input type="checkbox"/> GRAVEL	<input type="checkbox"/> HIGH	<input type="checkbox"/> SEWER	<input checked="" type="checkbox"/> STATIC	<input type="checkbox"/> B. TOPGRHY	COMMENT TY2018:Net Gen=\$1,774.64, Other Assessment=\$0.00 DE18 REMOVE OWN OCC didn't return app
<input type="checkbox"/> DIRT	<input type="checkbox"/> LOW	<input type="checkbox"/> GAS	<input type="checkbox"/> DECLINING	<input checked="" type="checkbox"/> C. Ex Front	
<input checked="" type="checkbox"/> SIDEWALKS	<input type="checkbox"/> ROLLING	<input type="checkbox"/> ELECTRIC	<input type="checkbox"/> OLD	<input type="checkbox"/> D. QUANTITY	
<input type="checkbox"/> CURBS	<input type="checkbox"/> STANDARD	<input checked="" type="checkbox"/> STANDARD	<input type="checkbox"/> STANDARD	<input type="checkbox"/> E. SZ/SHAPE	
				<input type="checkbox"/> F. RESTRICT	

LAND COMPUTATIONS

LAND TYPE	SIZE	M	RATE	C	INF	M	VALUE	C
F:Front	F141 D78	ST260	DP72	ADJ187	C:0.07	24,600	0	
TOTAL						24,600	0	

VALUATION SUMMARY

VALUE YEAR	2017	2014	2011				
REASON FOR CHANGE	RAPP	RAPP	RAPP				
APPRAISED VALUE	LAND 24,600	26,300	24,600				
	IMPR 112,600	99,700	93,200				
	TOTAL 137,200	126,000	117,800				
ASSESSED VALUE	LAND 8,610	9,210	8,610				
	IMPR 39,410	34,900	32,620				
	TOTAL 48,020	44,110	41,230				

OCCUPANCY	EXTERIOR
<input checked="" type="checkbox"/> SINGL FMLY	<input checked="" type="checkbox"/> WOOD
<input type="checkbox"/> DUPLEX	<input type="checkbox"/> STUCCO
<input type="checkbox"/> TRIPLEX	<input type="checkbox"/> ALM/VYNL
<input type="checkbox"/> CONVR	<input type="checkbox"/> CONC BLK
<input type="checkbox"/> MOBILE HM	<input type="checkbox"/> METAL
<input type="checkbox"/> BI/L TRI/L	<input type="checkbox"/> BRICK
<input type="checkbox"/> MOD/MAN	<input type="checkbox"/> STONE

ROOFING	ROOF TYPE
<input type="checkbox"/> METAL	<input type="checkbox"/> GABLE
<input type="checkbox"/> SLT/TLE	<input checked="" type="checkbox"/> HIP
<input checked="" type="checkbox"/> SHINGLES	<input type="checkbox"/> GAMBREL
<input type="checkbox"/> SHAKES	<input type="checkbox"/> MANSARD
<input type="checkbox"/> COMPOSITE	<input type="checkbox"/> FLAT

FLOORS	B	1	2	3	U
CONCRETE	<input checked="" type="checkbox"/>	<input type="checkbox"/>	<input type="checkbox"/>	<input type="checkbox"/>	<input type="checkbox"/>
WOOD	<input type="checkbox"/>	<input checked="" type="checkbox"/>	<input type="checkbox"/>	<input type="checkbox"/>	<input type="checkbox"/>
TILE/COMPO	<input checked="" type="checkbox"/>	<input type="checkbox"/>	<input type="checkbox"/>	<input type="checkbox"/>	<input type="checkbox"/>
CARPET	<input type="checkbox"/>	<input type="checkbox"/>	<input type="checkbox"/>	<input type="checkbox"/>	<input type="checkbox"/>

INT. FINISH	B	1	2	3	U
PLASTER/DW	<input type="checkbox"/>	<input checked="" type="checkbox"/>	<input type="checkbox"/>	<input type="checkbox"/>	<input type="checkbox"/>
PANELING	<input type="checkbox"/>	<input type="checkbox"/>	<input type="checkbox"/>	<input type="checkbox"/>	<input type="checkbox"/>
UNFINISHED	<input type="checkbox"/>	<input type="checkbox"/>	<input type="checkbox"/>	<input type="checkbox"/>	<input type="checkbox"/>

ACCOMMODATIONS					
# OF ROOMS		6			
BEDROOMS		3			
FIREPLACES		1			
HEAT & AC	B	1	2	3	U

NO HEAT	<input type="checkbox"/>	<input type="checkbox"/>	<input type="checkbox"/>	<input type="checkbox"/>	<input type="checkbox"/>
CTRL HEAT	<input checked="" type="checkbox"/>	<input checked="" type="checkbox"/>	<input type="checkbox"/>	<input type="checkbox"/>	<input type="checkbox"/>
HW/STEAM	<input type="checkbox"/>	<input type="checkbox"/>	<input type="checkbox"/>	<input type="checkbox"/>	<input type="checkbox"/>
ELECTRIC	<input type="checkbox"/>	<input type="checkbox"/>	<input type="checkbox"/>	<input type="checkbox"/>	<input type="checkbox"/>
HEAT PUMP	<input type="checkbox"/>	<input type="checkbox"/>	<input type="checkbox"/>	<input type="checkbox"/>	<input type="checkbox"/>
FLR/WALL	<input type="checkbox"/>	<input type="checkbox"/>	<input type="checkbox"/>	<input type="checkbox"/>	<input type="checkbox"/>
STVE/SPCE	<input type="checkbox"/>	<input type="checkbox"/>	<input type="checkbox"/>	<input type="checkbox"/>	<input type="checkbox"/>
GEOHERMAL	<input type="checkbox"/>	<input type="checkbox"/>	<input type="checkbox"/>	<input type="checkbox"/>	<input type="checkbox"/>
OUTSIDE	<input type="checkbox"/>	<input type="checkbox"/>	<input type="checkbox"/>	<input type="checkbox"/>	<input type="checkbox"/>
CTRL A/C	<input type="checkbox"/>	<input type="checkbox"/>	<input type="checkbox"/>	<input type="checkbox"/>	<input type="checkbox"/>

PLUMBING	BASE				
X FULL BATH	1				
X HALF BATH					
X FIXTURES					

FLOOR	AREA	CONST	VALUE
1	1640	FR	122,520
BSMT	820		10,660
SUBTOTAL			133,180
MULTI-FAMILY #	0		0
BSMT FINISH	820 S.F.		10,660
FIREPLACE #	1		4,000
HEATING	0 S.F.		0
AIR COND	0 S.F.		0
PLUMBING #	3		3,300
GARAGES & CARPORTS			4,700
EXTRA FEATURES			2,200
SUBTOTAL			158,040
GRADE FACTOR			105 %
UNADJUSTED VALUE			165,940
FACTOR			100 %

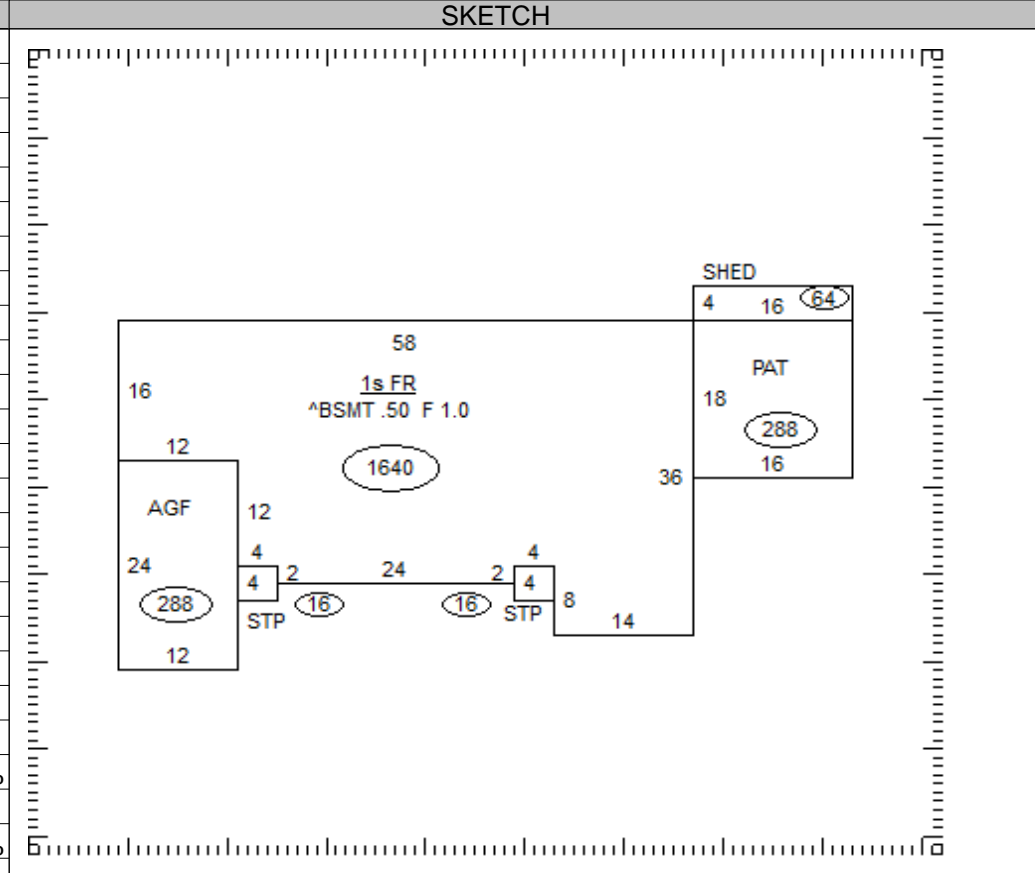

OCCUPANCY	ST.HT	SIZE	AREA	GRADE	PRICE	AGE	REMD	CND	UNADJ VAL	PHYS	PHYS VAL	FUNC	TRUE VAL
DWELLING	1	SK	1,640	C+		1953		A	165,940	42	96,250		112,600
1													
2													
3													
4													
5													
6													
7													
8													
9													
10													
11													

05-104600.0000

TOTAL 112,600

COMMENTS
 Dwelling has an Economic Factor of 117%