

BUTLER TWP-COLDWATER CORP / COLDWATER SD
08-28-454-020

PROP. CLASS		
5	1	0
NEIGHBORHOOD		
000506-TS50		
M	14B10	
B		
C	22	

05-099200.0000

TOBE ALISON M
TOBE ALISON M
402 W PLUM ST
COLDWATER, OH 45828

LEGAL INFORMATION
SELHORST SECOND ADDITION

LOT#: 602

	OWNERSHIP	ADDRESS	CITY	STATE	ZIP	DATE	AMOUNT	DEED:CONV#	JS	VALID
1	TOBE ALISON M	402 W PLUM ST	COLDWATER	OH	45828	05/12/2017	140,000	WDC : 303	<input type="checkbox"/>	<input checked="" type="checkbox"/>
2	STUMPF JACQUELYN R ETAL C/O J DALE TANGEMAN	402 W PLUM	COLDWATER	OH	45828	10/30/2002	100,000	: A : 0	<input type="checkbox"/>	<input checked="" type="checkbox"/>
3							0	0	<input type="checkbox"/>	<input type="checkbox"/>

X:	<input type="checkbox"/> TTO	LISTER: NS	DATE: 01/25/2005	TIME: 12:00:00 AM	<input type="checkbox"/> LETTER	<input checked="" type="checkbox"/> LETTER REC'D	GIS CODE
----	------------------------------	------------	------------------	-------------------	---------------------------------	--	----------

STREET/ROAD	TOPOGRAPHY	PU-UTILITIES-PR	NEIGHBORHOOD	INFLUENCE FACTORS				PROPERTY LOCATION
<input checked="" type="checkbox"/> PAVED <input type="checkbox"/> GRAVEL <input type="checkbox"/> DIRT <input checked="" type="checkbox"/> SIDEWALKS <input type="checkbox"/> CURBS	<input checked="" type="checkbox"/> LEVEL <input type="checkbox"/> HIGH <input type="checkbox"/> LOW <input type="checkbox"/> ROLLING <input type="checkbox"/> STANDARD	<input type="checkbox"/> WATER <input type="checkbox"/> SEWER <input type="checkbox"/> GAS <input type="checkbox"/> ELECTRIC <input checked="" type="checkbox"/> STANDARD	<input type="checkbox"/> IMPROVING <input checked="" type="checkbox"/> STATIC <input type="checkbox"/> DECLINING <input type="checkbox"/> OLD <input type="checkbox"/> STANDARD	<input type="checkbox"/> A. NO ROAD <input type="checkbox"/> B. TOPGRHY <input type="checkbox"/> C. Ex Front <input type="checkbox"/> D. QUANTITY <input type="checkbox"/> E. SZ/SHAPE	<input type="checkbox"/> F. RESTRICT <input type="checkbox"/> G. WOOD LT <input type="checkbox"/> H. VACANCY <input type="checkbox"/> I. WATER FRONT <input type="checkbox"/> J. OTHER/CDU	402 W PLUM ST, COLDWATER		
COMMENT								
TY2018:Net Gen=\$1,724.38, Other Assessment=\$0.00 DE15 RMV FP PER DATA MAILER DE16 DESKTOP REVIEW CHG: add BW DE18 REMOVE OWN OCC didn't return app								

LAND COMPUTATIONS

LAND TYPE	SIZE	M	RATE	C	INF	M	VALUE	C
F:Front	F72 D122	ST260	DP90	ADJ234			16,800	0
TOTAL							16,800	0

VALUATION SUMMARY

VALUE YEAR	2017	2016	2015	2014	2011
REASON FOR CHANGE	RAPP	MISC	REMB	RAPP	RAPP
APPRAISED	<u>LAND</u>	16,800	18,000	18,000	18,000
VALUE	<u>IMPR</u>	116,500	92,800	92,600	95,500
	<u>TOTAL</u>	133,300	110,800	110,600	113,500
ASSESSED	<u>LAND</u>	5,880	6,300	6,300	6,300
VALUE	<u>IMPR</u>	40,780	32,480	32,410	33,430
	<u>TOTAL</u>	46,660	38,780	38,710	39,730

OCCUPANCY	EXTERIOR	FLOOR	AREA	CONST	VALUE
<input checked="" type="checkbox"/> SNGL FMLY	<input type="checkbox"/> WOOD	1	272	FR	21,400
<input type="checkbox"/> DUPLEX	<input type="checkbox"/> STUCCO	1	1136	BRK	95,620
<input type="checkbox"/> TRIPLEX	<input type="checkbox"/> ALM/VYNL	.25	284	FR	16,980
<input type="checkbox"/> CONVR	<input type="checkbox"/> CONC BLK				
<input type="checkbox"/> MOBILE HM	<input type="checkbox"/> METAL				
<input type="checkbox"/> BI/L TRI/L	<input checked="" type="checkbox"/> BRICK				
<input type="checkbox"/> MOD/MAN	<input type="checkbox"/> STONE				

ROOFING	ROOF TYPE				VALUE
<input type="checkbox"/> METAL	<input checked="" type="checkbox"/> GABLE				
<input type="checkbox"/> SLT/TLE	<input type="checkbox"/> HIP				
<input checked="" type="checkbox"/> SHINGLES	<input type="checkbox"/> GAMBREL				
<input type="checkbox"/> SHAKES	<input type="checkbox"/> MANSARD				
<input type="checkbox"/> COMPOSITE	<input type="checkbox"/> FLAT				
BSMT		1056			13,730
SUBTOTAL					147,730

FLOORS	B	1	2	3	U			VALUE	
CONCRETE	<input checked="" type="checkbox"/>	<input type="checkbox"/>	<input type="checkbox"/>	<input type="checkbox"/>	<input type="checkbox"/>	MULTI-FAMILY #	0	0	
WOOD	<input type="checkbox"/>	<input checked="" type="checkbox"/>	<input checked="" type="checkbox"/>	<input type="checkbox"/>	<input type="checkbox"/>	BSMT FINISH	0 S.F.	0	
TILE/COMPO	<input type="checkbox"/>	<input checked="" type="checkbox"/>	<input checked="" type="checkbox"/>	<input type="checkbox"/>	<input type="checkbox"/>	FIREPLACE #	0	0	
CARPET	<input type="checkbox"/>	<input checked="" type="checkbox"/>	<input checked="" type="checkbox"/>	<input checked="" type="checkbox"/>	<input type="checkbox"/>	HEATING	0 S.F.	0	
INT. FINISH		B	1	2	3	AIR COND	1,408 S.F.	2,110	
PLASTER/DW	<input type="checkbox"/>	<input checked="" type="checkbox"/>	<input checked="" type="checkbox"/>	<input checked="" type="checkbox"/>	<input type="checkbox"/>	PLUMBING #	1	1,100	
PANELING	<input type="checkbox"/>	<input type="checkbox"/>	<input type="checkbox"/>	<input type="checkbox"/>	<input type="checkbox"/>	GARAGES & CARPORTS		5,100	
UNFINISHED	<input type="checkbox"/>	<input type="checkbox"/>	<input type="checkbox"/>	<input type="checkbox"/>	<input type="checkbox"/>	EXTRA FEATURES		7,400	
ACCOMMODATIONS					SUBTOTAL		163,440		
# OF ROOMS			5	2		GRADE FACTOR		105 %	
BEDROOMS			1	2		UNADJUSTED VALUE		171,610	
FIREPLACES						FACTOR		100 %	
HEAT & AC	B	1	2	3	U				
NO HEAT	<input type="checkbox"/>	<input type="checkbox"/>	<input type="checkbox"/>	<input type="checkbox"/>	<input type="checkbox"/>				
CTRL HEAT	<input type="checkbox"/>	<input checked="" type="checkbox"/>	<input checked="" type="checkbox"/>	<input checked="" type="checkbox"/>	<input type="checkbox"/>				
HW/STEAM	<input type="checkbox"/>	<input checked="" type="checkbox"/>	<input checked="" type="checkbox"/>	<input checked="" type="checkbox"/>	<input type="checkbox"/>				
ELECTRIC	<input type="checkbox"/>	<input type="checkbox"/>	<input type="checkbox"/>	<input type="checkbox"/>	<input type="checkbox"/>				
HEAT PUMP	<input type="checkbox"/>	<input type="checkbox"/>	<input type="checkbox"/>	<input type="checkbox"/>	<input type="checkbox"/>				
FLR/WALL	<input type="checkbox"/>	<input type="checkbox"/>	<input type="checkbox"/>	<input type="checkbox"/>	<input type="checkbox"/>				
STVE/SPCE	<input type="checkbox"/>	<input type="checkbox"/>	<input type="checkbox"/>	<input type="checkbox"/>	<input type="checkbox"/>				
GEOHERMAL	<input type="checkbox"/>	<input type="checkbox"/>	<input type="checkbox"/>	<input type="checkbox"/>	<input type="checkbox"/>				
OUTSIDE	<input type="checkbox"/>	<input type="checkbox"/>	<input type="checkbox"/>	<input type="checkbox"/>	<input type="checkbox"/>				
CTRL A/C	<input type="checkbox"/>	<input checked="" type="checkbox"/>	<input checked="" type="checkbox"/>	<input type="checkbox"/>	<input type="checkbox"/>				
PLUMBING	BASE					<input checked="" type="checkbox"/>			
X FULL BATH									
X HALF BATH									
X FIXTURES	1								

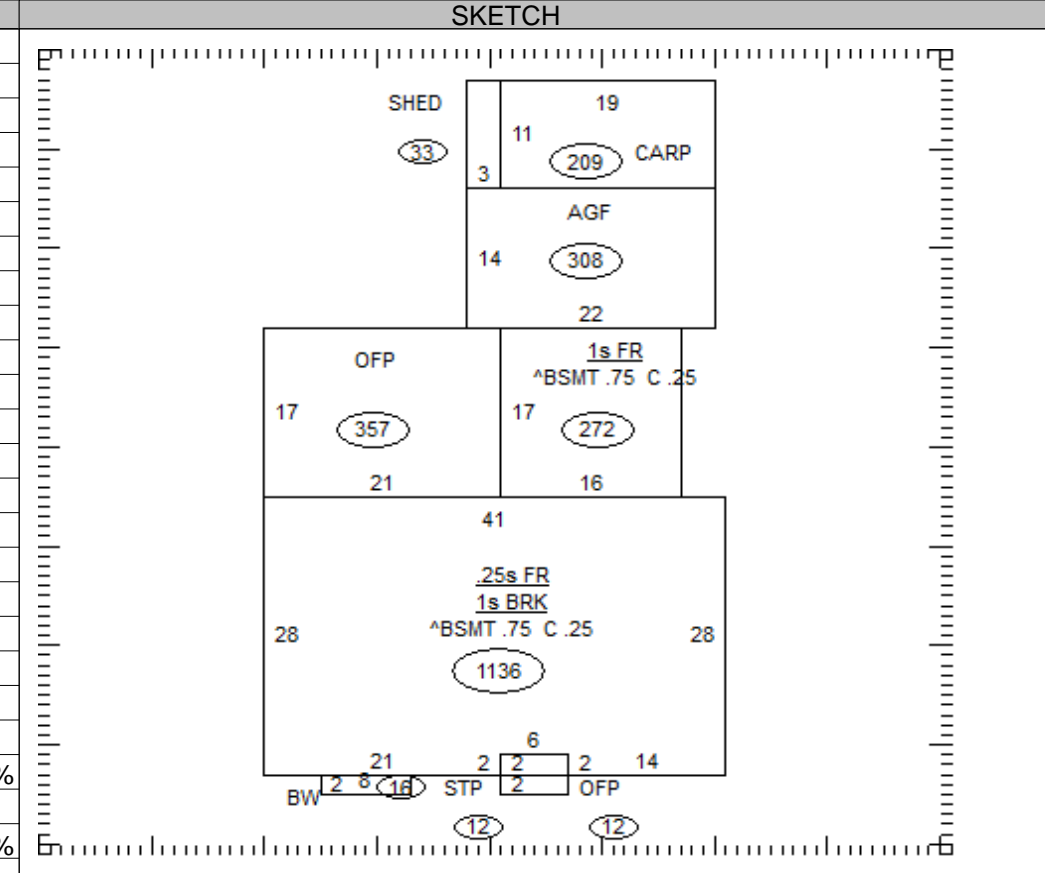

OCCUPANCY	ST.HT	SIZE	AREA	GRADE	PRICE	AGE	REMD	CND	UNADJ VAL	PHYS	PHYS VAL	FUNC	TRUE VAL
DWELLING	1.25	SK	1,692	C+		1950		A	171,610	42	99,530		116,500
1													
2													
3													
4													
5													
6													
7													
8													
9													
10													
11													

05-099200.0000 TOTAL 116,500

COMMENTS

Dwelling has an Economic Factor of 117%