

1 OF 2		
PROP. CLASS		
5	1	0
NEIGHBORHOOD		
000505-TM50		
M	14A7	
B		
C	17	



05-094600.0000

FISHER BETSY K
FISHER BETSY K
311 N SECOND ST
COLDWATER, OH 45828

LEGAL INFORMATION
KREIGERS ADD

LOT#: 557

OWNERSHIP	ADDRESS	CITY	STATE	ZIP	DATE	AMOUNT	DEED:CONV#	JS	VALID
1 FISHER BETSY K	311 N SECOND ST	COLDWATER	OH	45828	04/07/2016	68,000	WDC : 211	<input type="checkbox"/>	<input checked="" type="checkbox"/>
2 GELHAUS KENNETH B ETAL	806 OAKWOOD DR	COLDWATER	OH	45828	10/13/2015	0	QCE : X : 0	<input type="checkbox"/>	<input type="checkbox"/>
3 GELHAUS MARY ANN	311 N SECOND ST	COLDWATER	OH	45828	02/12/2007	0	QCE : X : 0	<input type="checkbox"/>	<input type="checkbox"/>

X:	<input type="checkbox"/> TTO	LISTER: NS	DATE: 03/15/2005	TIME: 12:00:00 AM	<input type="checkbox"/> LETTER	<input checked="" type="checkbox"/> LETTER REC'D	GIS CODE		
STREET/ROAD	TOPOGRAPHY	PU-UTILITIES-PR	NEIGHBORHOOD	INFLUENCE FACTORS			PROPERTY LOCATION		
<input checked="" type="checkbox"/> PAVED	<input checked="" type="checkbox"/> LEVEL	<input type="checkbox"/> WATER	<input type="checkbox"/> IMPROVING	<input type="checkbox"/> A. NO ROAD	<input type="checkbox"/> F. RESTRICT	311 N SECOND ST, COLDWATER			
<input type="checkbox"/> GRAVEL	<input type="checkbox"/> HIGH	<input type="checkbox"/> SEWER	<input checked="" type="checkbox"/> STATIC	<input type="checkbox"/> B. TOPGRHY	<input type="checkbox"/> G. WOOD LT	COMMENT TY2018:Net Gen=\$1,178.22, Other Assessment=\$0.00 DE16 NO CHNG//REAR LOT NOT CALCULATED DE16 DESKTOP REVIEW CHG: COR EX FEATURES			
<input type="checkbox"/> DIRT	<input type="checkbox"/> LOW	<input type="checkbox"/> GAS	<input type="checkbox"/> DECLINING	<input type="checkbox"/> C. Ex Front	<input type="checkbox"/> H. VACANCY				
<input type="checkbox"/> SIDEWALKS	<input type="checkbox"/> ROLLING	<input type="checkbox"/> ELECTRIC	<input type="checkbox"/> OLD	<input type="checkbox"/> D. QUANTITY	<input type="checkbox"/> I. WATER FRONT				
<input type="checkbox"/> CURBS	<input type="checkbox"/> STANDARD	<input checked="" type="checkbox"/> STANDARD	<input type="checkbox"/> STANDARD	<input type="checkbox"/> E. SZ/SHAPE	<input type="checkbox"/> J. OTHER/CDU				

LAND COMPUTATIONS						
LAND TYPE	SIZE	M	RATE	C	INF	M VALUE C
F:Front	F49 D140	ST200	DP96	ADJ192		9,400 0
TOTAL						9,400 0

VALUATION SUMMARY						
VALUE YEAR	2017	2016	2014	2011	2009	
REASON FOR CHANGE	RAPP	MISC	RAPP	RAPP	MISC	
APPRAISED	LAND	9,400	9,900	9,900	9,400	8,200
VALUE	IMPR	84,100	65,800	65,000	61,900	55,800
	TOTAL	93,500	75,700	74,900	71,300	64,000
ASSESSED	LAND	3,290	3,470	3,470	3,290	2,870
	IMPR	29,440	23,030	22,750	21,670	19,530
	TOTAL	32,730	26,500	26,220	24,960	22,400

OCCUPANCY	EXTERIOR
<input checked="" type="checkbox"/> SINGL FMLY	<input type="checkbox"/> WOOD
<input type="checkbox"/> DUPLEX	<input type="checkbox"/> STUCCO
<input type="checkbox"/> TRIPLEX	<input checked="" type="checkbox"/> ALM/VYNL
<input type="checkbox"/> CONVR	<input type="checkbox"/> CONC BLK
<input type="checkbox"/> MOBILE HM	<input type="checkbox"/> METAL
<input type="checkbox"/> BI/L TRI/L	<input type="checkbox"/> BRICK
<input type="checkbox"/> MOD/MAN	<input type="checkbox"/> STONE

ROOFING	ROOF TYPE
<input type="checkbox"/> METAL	<input checked="" type="checkbox"/> GABLE
<input type="checkbox"/> SLT/TLE	<input type="checkbox"/> HIP
<input checked="" type="checkbox"/> SHINGLES	<input type="checkbox"/> GAMBREL
<input type="checkbox"/> SHAKES	<input type="checkbox"/> MANSARD
<input type="checkbox"/> COMPOSITE	<input type="checkbox"/> FLAT

FLOORS	B	1	2	3	U
CONCRETE	<input checked="" type="checkbox"/>	<input type="checkbox"/>	<input type="checkbox"/>	<input type="checkbox"/>	<input type="checkbox"/>
WOOD	<input type="checkbox"/>	<input checked="" type="checkbox"/>	<input checked="" type="checkbox"/>	<input type="checkbox"/>	<input type="checkbox"/>
TILE/COMPO	<input type="checkbox"/>	<input type="checkbox"/>	<input type="checkbox"/>	<input type="checkbox"/>	<input type="checkbox"/>
CARPET	<input type="checkbox"/>	<input type="checkbox"/>	<input type="checkbox"/>	<input type="checkbox"/>	<input type="checkbox"/>

INT. FINISH	B	1	2	3	U
PLASTER/DW	<input type="checkbox"/>	<input checked="" type="checkbox"/>	<input checked="" type="checkbox"/>	<input type="checkbox"/>	<input type="checkbox"/>
PANELING	<input type="checkbox"/>	<input type="checkbox"/>	<input type="checkbox"/>	<input type="checkbox"/>	<input type="checkbox"/>
UNFINISHED	<input checked="" type="checkbox"/>	<input type="checkbox"/>	<input type="checkbox"/>	<input type="checkbox"/>	<input type="checkbox"/>

ACCOMMODATIONS					
# OF ROOMS		5	2		
BEDROOMS		1	2		
FIREPLACES					

HEAT & AC	B	1	2	3	U
NO HEAT	<input type="checkbox"/>	<input type="checkbox"/>	<input type="checkbox"/>	<input type="checkbox"/>	<input type="checkbox"/>
CTRL HEAT	<input type="checkbox"/>	<input checked="" type="checkbox"/>	<input checked="" type="checkbox"/>	<input type="checkbox"/>	<input type="checkbox"/>
HW/STEAM	<input type="checkbox"/>	<input type="checkbox"/>	<input type="checkbox"/>	<input type="checkbox"/>	<input type="checkbox"/>
ELECTRIC	<input type="checkbox"/>	<input type="checkbox"/>	<input type="checkbox"/>	<input type="checkbox"/>	<input type="checkbox"/>
HEAT PUMP	<input type="checkbox"/>	<input type="checkbox"/>	<input type="checkbox"/>	<input type="checkbox"/>	<input type="checkbox"/>
FLR/WALL	<input type="checkbox"/>	<input type="checkbox"/>	<input type="checkbox"/>	<input type="checkbox"/>	<input type="checkbox"/>
STVE/SPCE	<input type="checkbox"/>	<input type="checkbox"/>	<input type="checkbox"/>	<input type="checkbox"/>	<input type="checkbox"/>
GEO THERMAL	<input type="checkbox"/>	<input type="checkbox"/>	<input type="checkbox"/>	<input type="checkbox"/>	<input type="checkbox"/>
OUTSIDE	<input type="checkbox"/>	<input type="checkbox"/>	<input type="checkbox"/>	<input type="checkbox"/>	<input type="checkbox"/>
CTRL A/C	<input type="checkbox"/>	<input checked="" type="checkbox"/>	<input checked="" type="checkbox"/>	<input type="checkbox"/>	<input type="checkbox"/>

PLUMBING	BASE
X FULL BATH	<input type="checkbox"/>
X HALF BATH	<input type="checkbox"/>
X FIXTURES	<input type="checkbox"/>

FLOOR	AREA	CONST	VALUE
1	1160	FR	101,430
.5	288	FR	18,390
BSMT	840		10,920
SUBTOTAL			130,740
MULTI-FAMILY #	0		0
BSMT FINISH	0 S.F.		0
FIREPLACE #	0		0
HEATING	0 S.F.		0
AIR COND	1,448 S.F.		2,170
PLUMBING #	2		2,200
GARAGES & CARPORTS			3,200
EXTRA FEATURES			2,900
SUBTOTAL			141,210
GRADE FACTOR			100 %
UNADJUSTED VALUE			141,210
FACTOR			100 %

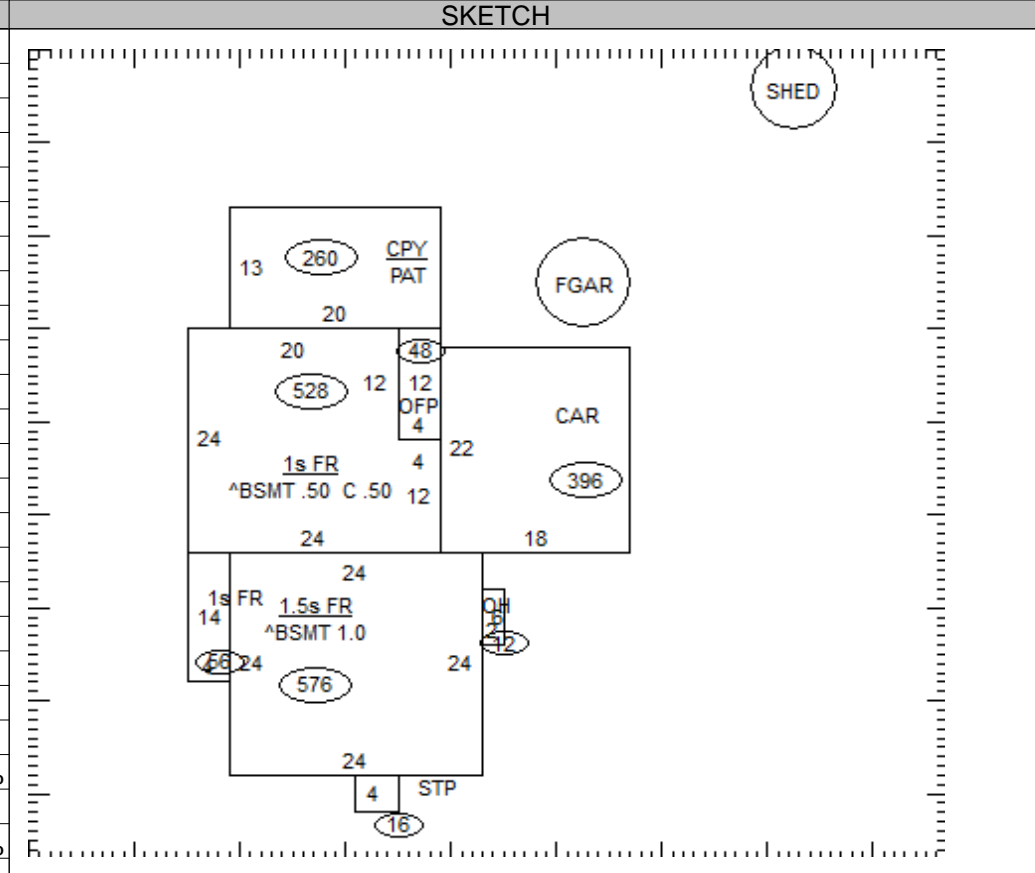

OCCUPANCY	ST.HT	SIZE	AREA	GRADE	PRICE	AGE	REMD	CND	UNADJ VAL	PHYS	PHYS VAL	FUNC	TRUE VAL
DWELLING	1.5	SK	1,448	C		1918	1959	A	141,210	45	77,670		83,900
1 Gar - Frame	8	12x20	240	D	12.64	1935		A	3,030	95	150		200
2 Shed	PP	8x10	80	C		1990		A		47			0
3													
4													
5													
6													
7													
8													
9													
10													
11													

05-094600.0000

TOTAL 84,100

COMMENTS

Dwelling has an Economic Factor of 108%



05-094600.0000

BUTLER TWP-COLDWATER CORP / COLDWATER SD
08-27-351-002

2 OF 2		
PROP. CLASS		
5	1	0
NEIGHBORHOOD		
000505-TM50		
M	14A7	
B		
C	17	

FISHER BETSY K

FISHER BETSY K
311 N SECOND ST
COLDWATER, OH 45828

LEGAL INFORMATION

KREIGERS ADD

LOT#: 557

	OWNERSHIP	ADDRESS	CITY	STATE	ZIP	DATE	AMOUNT	DEED:CONV#	JS	VALID
1		GELHAUS EDWARD W & MARY 311 N SECOND ST	COLDWATER	OH	45828		0	:0	<input type="checkbox"/>	<input type="checkbox"/>
2							0	0	<input type="checkbox"/>	<input type="checkbox"/>
3							0	0	<input type="checkbox"/>	<input type="checkbox"/>

X: TTO LISTER: NS DATE: 03/15/2005 TIME: 12:00:00 AM LETTER LETTER REC'D GIS CODE

STREET/ROAD	TOPOGRAPHY	PU-UTILITIES-PR	NEIGHBORHOOD	INFLUENCE FACTORS		PROPERTY LOCATION
<input checked="" type="checkbox"/> PAVED <input type="checkbox"/> GRAVEL <input type="checkbox"/> DIRT <input type="checkbox"/> SIDEWALKS <input type="checkbox"/> CURBS	<input checked="" type="checkbox"/> LEVEL <input type="checkbox"/> HIGH <input type="checkbox"/> LOW <input type="checkbox"/> ROLLING <input type="checkbox"/> STANDARD	<input type="checkbox"/> WATER <input type="checkbox"/> SEWER <input type="checkbox"/> GAS <input type="checkbox"/> ELECTRIC <input checked="" type="checkbox"/> STANDARD	<input type="checkbox"/> IMPROVING <input checked="" type="checkbox"/> STATIC <input type="checkbox"/> DECLINING <input type="checkbox"/> OLD <input type="checkbox"/> STANDARD	<input type="checkbox"/> A. NO ROAD <input type="checkbox"/> B. TOPGRHY <input type="checkbox"/> C. Ex Front <input type="checkbox"/> D. QUANTITY <input type="checkbox"/> E. SZ/SHAPE	<input type="checkbox"/> F. RESTRICT <input type="checkbox"/> G. WOOD LT <input type="checkbox"/> H. VACANCY <input type="checkbox"/> I. WATER FRONT <input type="checkbox"/> J. OTHER/CDU	311 N SECOND ST, COLDWATER COMMENT

LAND COMPUTATIONS							
LAND TYPE	SIZE	M	RATE	C	INF	M	VALUE C
TOTAL						9,400	0

VALUATION SUMMARY

VALUE YEAR	REASON FOR CHANGE	APPRaised	LAND IMPR	TOTAL	ASSESSED	LAND IMPR	TOTAL

OCCUPANCY	EXTERIOR	FLOOR	AREA	CONST	VALUE	SKETCH																		
<input type="checkbox"/> SNGL FMLY	<input type="checkbox"/> WOOD					<p>The sketch shows a complex floor plan with several units. Key features include: a 'SHED' in the top right; a 'CPY PAT' (copy patio) at the top left; a 'CAR' (carport) on the right side; and various rooms labeled with numbers like 13, 20, 24, 14, 12, 18, 4, 16, 66, 576, 528, 48, 12, 4, 22, 12, 24, 24, 4, 12, 24, 14, 24, 24, 4, 12, 16, 18, 24, 24, 4, 12. Some rooms are labeled with values in circles, such as 260, 528, 396, 576, and 16. There are also labels for '1s FR', '1.5s FR', '12 OFF', and 'STP'.</p>																		
<input type="checkbox"/> DUPLEX	<input type="checkbox"/> STUCCO																							
<input type="checkbox"/> TRIPLEX	<input type="checkbox"/> ALM/VYNL																							
<input type="checkbox"/> CONVR	<input type="checkbox"/> CONC BLK																							
<input type="checkbox"/> MOBILE HM	<input type="checkbox"/> METAL																							
<input type="checkbox"/> BI/L TRI/L	<input type="checkbox"/> BRICK																							
<input type="checkbox"/> MOD/MAN	<input type="checkbox"/> STONE																							
ROOFING		ROOF TYPE																						
<input type="checkbox"/> METAL	<input type="checkbox"/> GABLE																							
<input type="checkbox"/> SLT/TLE	<input type="checkbox"/> HIP																							
<input type="checkbox"/> SHINGLES	<input type="checkbox"/> GAMBREL																							
<input type="checkbox"/> SHAKES	<input type="checkbox"/> MANSARD																							
<input type="checkbox"/> COMPOSITE	<input type="checkbox"/> FLAT																							
SUBTOTAL					0																			
FLOORS		B	1	2	3									U	MULTI-FAMILY #		0	0						
CONCRETE	<input type="checkbox"/>	<input type="checkbox"/>	<input type="checkbox"/>	<input type="checkbox"/>	<input type="checkbox"/>	<input type="checkbox"/>	BSMT FINISH		0	S.F.	0													
WOOD	<input type="checkbox"/>	<input type="checkbox"/>	<input type="checkbox"/>	<input type="checkbox"/>	<input type="checkbox"/>	<input type="checkbox"/>	FIREPLACE #		0	0														
TILE/COMPO	<input type="checkbox"/>	<input type="checkbox"/>	<input type="checkbox"/>	<input type="checkbox"/>	<input type="checkbox"/>	<input type="checkbox"/>	HEATING		0	S.F.	0													
CARPET	<input type="checkbox"/>	<input type="checkbox"/>	<input type="checkbox"/>	<input type="checkbox"/>	<input type="checkbox"/>	<input type="checkbox"/>	AIR COND		0	S.F.	0													
INT. FINISH		B	1	2	3	U	PLUMBING #		0	0														
PLASTER/DW	<input type="checkbox"/>	<input type="checkbox"/>	<input type="checkbox"/>	<input type="checkbox"/>	<input type="checkbox"/>	<input type="checkbox"/>	GARAGES & CARPORTS				0													
PANELING	<input type="checkbox"/>	<input type="checkbox"/>	<input type="checkbox"/>	<input type="checkbox"/>	<input type="checkbox"/>	<input type="checkbox"/>	EXTRA FEATURES				0													
UNFINISHED	<input type="checkbox"/>	<input type="checkbox"/>	<input type="checkbox"/>	<input type="checkbox"/>	<input type="checkbox"/>	<input type="checkbox"/>	SUBTOTAL				0													
ACCOMMODATIONS							GRADE FACTOR			%														
# OF ROOMS							UNADJUSTED VALUE		0	0														
BEDROOMS							FACTOR			%														
FIREPLACES							OCCUPANCY				ST.HT	SIZE	AREA	GRADE	PRICE	AGE	REMD	CND	UNADJ VAL	PHYS	PHYS VAL	FUNC	TRUE VAL	
HEAT & AC		B	1	2	3	U	DWELLING					SK												
NO HEAT	<input type="checkbox"/>	<input type="checkbox"/>	<input type="checkbox"/>	<input type="checkbox"/>	<input type="checkbox"/>	<input type="checkbox"/>	1																	
CTRL HEAT	<input type="checkbox"/>	<input type="checkbox"/>	<input type="checkbox"/>	<input type="checkbox"/>	<input type="checkbox"/>	<input type="checkbox"/>	2																	
HW/STEAM	<input type="checkbox"/>	<input type="checkbox"/>	<input type="checkbox"/>	<input type="checkbox"/>	<input type="checkbox"/>	<input type="checkbox"/>	3																	
ELECTRIC	<input type="checkbox"/>	<input type="checkbox"/>	<input type="checkbox"/>	<input type="checkbox"/>	<input type="checkbox"/>	<input type="checkbox"/>	4																	
HEAT PUMP	<input type="checkbox"/>	<input type="checkbox"/>	<input type="checkbox"/>	<input type="checkbox"/>	<input type="checkbox"/>	<input type="checkbox"/>	5																	
FLR/WALL	<input type="checkbox"/>	<input type="checkbox"/>	<input type="checkbox"/>	<input type="checkbox"/>	<input type="checkbox"/>	<input type="checkbox"/>	6																	
STVE/SPCE	<input type="checkbox"/>	<input type="checkbox"/>	<input type="checkbox"/>	<input type="checkbox"/>	<input type="checkbox"/>	<input type="checkbox"/>	7																	
GEO THERMAL	<input type="checkbox"/>	<input type="checkbox"/>	<input type="checkbox"/>	<input type="checkbox"/>	<input type="checkbox"/>	<input type="checkbox"/>	8																	
OUTSIDE	<input type="checkbox"/>	<input type="checkbox"/>	<input type="checkbox"/>	<input type="checkbox"/>	<input type="checkbox"/>	<input type="checkbox"/>	9																	
CTRL A/C	<input type="checkbox"/>	<input type="checkbox"/>	<input type="checkbox"/>	<input type="checkbox"/>	<input type="checkbox"/>	<input type="checkbox"/>	10																	
PLUMBING		BASE					<input type="checkbox"/>	11																
X FULL BATH							TOTAL															0		
X HALF BATH							COMMENTS																	
X FIXTURES																								

05-094600.0000

TOTAL 0

COMMENTS