

03-013600.0000

LIST JOSHUA D & SAMANTHA S

LIST JOSHUA D & SAMANTHA S  
4288 BUSCHOR RD  
COLDWATER, OH 45828

LEGAL INFORMATION

PT NW SE

RTS: 002-06-21  
Acres:5.0220

	OWNERSHIP	ADDRESS	CITY	STATE	ZIP	DATE	AMOUNT	DEED:CONV#	JS	VALID
1	LIST JOSHUA D & SAMANTHA	4288 BUSCHOR RD	COLDWATER	OH	45828	05/11/2017	270,000	WDC : 298	<input type="checkbox"/>	<input checked="" type="checkbox"/>
2	CULLY TED D	4288 BUSCHOR RD	COLDWATER	OH	45828	03/21/2017	0	QCE : X : 0	<input type="checkbox"/>	<input type="checkbox"/>
3	CULLY TED D & GRACE L	4288 BUSCHOR RD	COLDWATER	OH	45828	09/15/1997	170,000	: A : 0	<input type="checkbox"/>	<input checked="" type="checkbox"/>

X:  TTO LISTER: JO DATE: 04/01/2005 TIME: 12:00:00 AM  LETTER  LETTER REC'D GIS CODE

STREET/ROAD	TOPOGRAPHY	PU-UTILITIES-PR	NEIGHBORHOOD	INFLUENCE FACTORS	PROPERTY LOCATION
<input checked="" type="checkbox"/> PAVED	<input checked="" type="checkbox"/> LEVEL	<input type="checkbox"/> WATER <input type="checkbox"/>	<input type="checkbox"/> IMPROVING	<input type="checkbox"/> A. NO ROAD <input type="checkbox"/> F. RESTRICT	4288 BUSCHOR RD, COLDWATER <b>COMMENT</b> TY2018:Net Gen=\$3,412.16, Other Assessment=\$0.00 DE17 DESKTOP RWV CHG: ADD PAT, RFX TO OFF DE18 REMOVE OWN OCC didn't return app
<input type="checkbox"/> GRAVEL	<input type="checkbox"/> HIGH	<input type="checkbox"/> SEWER <input type="checkbox"/>	<input checked="" type="checkbox"/> STATIC	<input type="checkbox"/> B. TOPGRHY <input type="checkbox"/> G. WOOD LT	
<input type="checkbox"/> DIRT	<input type="checkbox"/> LOW	<input type="checkbox"/> GAS <input type="checkbox"/>	<input type="checkbox"/> DECLINING	<input type="checkbox"/> C. Ex Front <input type="checkbox"/> H. VACANCY	
<input type="checkbox"/> SIDEWALKS	<input type="checkbox"/> ROLLING	<input type="checkbox"/> ELECTRIC <input type="checkbox"/>	<input type="checkbox"/> OLD	<input type="checkbox"/> D. QUANTITY <input type="checkbox"/> I. WATER FRONT	
<input type="checkbox"/> CURBS	<input type="checkbox"/> STANDARD	<input checked="" type="checkbox"/> STANDARD	<input type="checkbox"/> STANDARD	<input type="checkbox"/> E. SZ/SHAPE <input type="checkbox"/> J. OTHER/CDU	

LAND COMPUTATIONS							
LAND TYPE	SIZE	M	RATE	C	INF	M	VALUE C
HS:Home Site	AC:1		16500			16,500	0
SM:Small Acreage	AC:4.022		6200			24,900	0
Total Acres: 5.0220						TOTAL	41,400 0

VALUATION SUMMARY							
VALUE YEAR	2017	2017	2014	2013	2011	2011	
REASON FOR CHANGE	RAPP	MISC	RAPP	MISC	MISC	RAPP	
APPRAISED	LAND	41,400	46,000	46,000	39,900	39,900	
VALUE	IMPR	222,400	202,800	204,700	177,900	178,100	
	TOTAL	263,800	248,800	250,700	217,800	218,000	
ASSESSED	LAND	14,490	16,100	16,100	13,970	13,970	
	IMPR	77,840	70,980	71,650	62,270	62,340	
	TOTAL	92,330	87,080	87,750	76,240	76,310	

OCCUPANCY	EXTERIOR	FLOOR	AREA	CONST	VALUE
<input checked="" type="checkbox"/> SNGL FMLY	<input checked="" type="checkbox"/> WOOD	1	1704	FR	124,530
<input type="checkbox"/> DUPLEX	<input type="checkbox"/> STUCCO	.5	87	FR	4,640
<input type="checkbox"/> TRIPLEX	<input type="checkbox"/> ALM/VYNL	2ND	602	FR	21,120
<input type="checkbox"/> CONVR	<input type="checkbox"/> CONC BLK				
<input type="checkbox"/> MOBILE HM	<input type="checkbox"/> METAL				
<input type="checkbox"/> BI/L TRI/L	<input type="checkbox"/> BRICK				
<input type="checkbox"/> MOD/MAN	<input type="checkbox"/> STONE				

ROOFING	ROOF TYPE
<input type="checkbox"/> METAL	<input checked="" type="checkbox"/> GABLE
<input type="checkbox"/> SLT/TLE	<input type="checkbox"/> HIP
<input checked="" type="checkbox"/> SHINGLES	<input type="checkbox"/> GAMBREL
<input type="checkbox"/> SHAKES	<input type="checkbox"/> MANSARD
<input type="checkbox"/> COMPOSITE	<input type="checkbox"/> FLAT

FLOORS	B	1	2	3	U
CONCRETE	<input type="checkbox"/>	<input type="checkbox"/>	<input type="checkbox"/>	<input type="checkbox"/>	<input type="checkbox"/>
WOOD	<input type="checkbox"/>	<input type="checkbox"/>	<input type="checkbox"/>	<input type="checkbox"/>	<input type="checkbox"/>
TILE/COMPO	<input type="checkbox"/>	<input checked="" type="checkbox"/>	<input type="checkbox"/>	<input type="checkbox"/>	<input type="checkbox"/>
CARPET	<input type="checkbox"/>	<input type="checkbox"/>	<input checked="" type="checkbox"/>	<input checked="" type="checkbox"/>	<input type="checkbox"/>

INT. FINISH	B	1	2	3	U
PLASTER/DW	<input type="checkbox"/>	<input checked="" type="checkbox"/>	<input checked="" type="checkbox"/>	<input checked="" type="checkbox"/>	<input type="checkbox"/>
PANELING	<input type="checkbox"/>	<input type="checkbox"/>	<input type="checkbox"/>	<input type="checkbox"/>	<input type="checkbox"/>
UNFINISHED	<input type="checkbox"/>	<input type="checkbox"/>	<input type="checkbox"/>	<input type="checkbox"/>	<input type="checkbox"/>

ACCOMMODATIONS					
# OF ROOMS	7				
BEDROOMS	2				
FIREPLACES	2				
HEAT & AC	B	1	2	3	U
NO HEAT	<input type="checkbox"/>	<input type="checkbox"/>	<input type="checkbox"/>	<input type="checkbox"/>	<input type="checkbox"/>
CTRL HEAT	<input type="checkbox"/>	<input type="checkbox"/>	<input type="checkbox"/>	<input type="checkbox"/>	<input type="checkbox"/>
HW/STEAM	<input type="checkbox"/>	<input type="checkbox"/>	<input type="checkbox"/>	<input type="checkbox"/>	<input type="checkbox"/>
ELECTRIC	<input type="checkbox"/>	<input type="checkbox"/>	<input type="checkbox"/>	<input type="checkbox"/>	<input type="checkbox"/>
HEAT PUMP	<input type="checkbox"/>	<input checked="" type="checkbox"/>	<input checked="" type="checkbox"/>	<input checked="" type="checkbox"/>	<input type="checkbox"/>
FLR/WALL	<input type="checkbox"/>	<input type="checkbox"/>	<input type="checkbox"/>	<input type="checkbox"/>	<input type="checkbox"/>
STVE/SPCE	<input type="checkbox"/>	<input type="checkbox"/>	<input type="checkbox"/>	<input type="checkbox"/>	<input type="checkbox"/>
GEO THERMAL	<input type="checkbox"/>	<input type="checkbox"/>	<input type="checkbox"/>	<input type="checkbox"/>	<input type="checkbox"/>
OUTSIDE	<input type="checkbox"/>	<input type="checkbox"/>	<input type="checkbox"/>	<input type="checkbox"/>	<input type="checkbox"/>
CTRL A/C	<input type="checkbox"/>	<input checked="" type="checkbox"/>	<input checked="" type="checkbox"/>	<input checked="" type="checkbox"/>	<input type="checkbox"/>

PLUMBING	BASE
X FULL BATH	1
X HALF BATH	1
X FIXTURES	1

SUBTOTAL		150,290
MULTI-FAMILY #	0	0
BSMT FINISH	0 S.F.	0
FIREPLACE #	2	8,000
HEATING	0 S.F.	0
AIR COND	2,393 S.F.	3,590
PLUMBING #	6	6,600
GARAGES & CARPORTS		8,200
EXTRA FEATURES		21,500
SUBTOTAL		198,180
GRADE FACTOR		115 %
UNADJUSTED VALUE		227,910
FACTOR		100 %

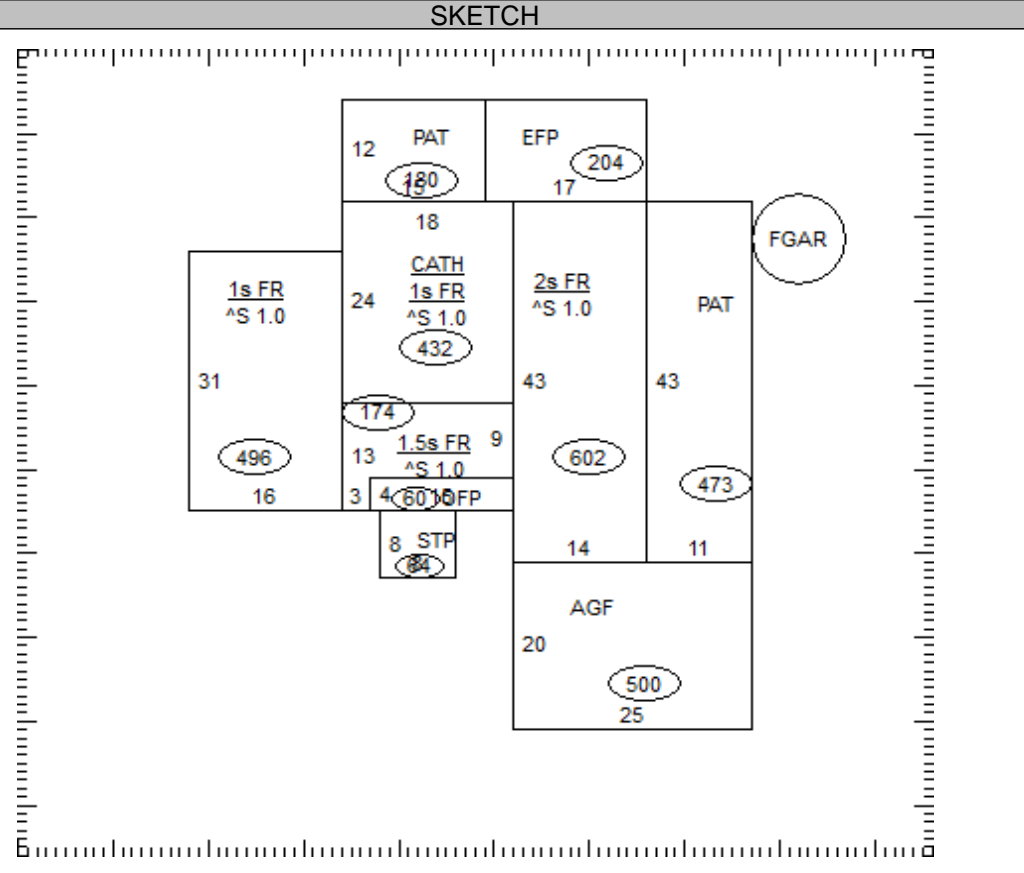

OCCUPANCY	ST.HT	SIZE	AREA	GRADE	PRICE	AGE	REMD	CND	UNADJ VAL	PHYS	PHYS VAL	FUNC	TRUE VAL
DWELLING	2	SK	2,393	B-		1985		A	227,910	24	173,210		213,000
1 Gar - Frame	10	28x30	840	C	15.80	2000		A	13,270	29	9,420		9,400
2													
3													
4													
5													
6													
7													
8													
9													
10													
11													

03-013600.0000	TOTAL	222,400
----------------	-------	---------

**COMMENTS**

41 L/F OF STONE TRIM-8' HIGH  
Dwelling has an Economic Factor of 123%