

1 OF 1		
PROP. CLASS		
5	1	0
NEIGHBORHOOD		
000205-RS50		
M	01	
B		
C	36	

02-001600.0000

**RISCH THOMAS J & BARBARA J**

RISCH THOMAS J & BARBARA J  
5540 JOHNSTON RD  
CELINA, OH 45822

**LEGAL INFORMATION**

S FR SEC

RTS: 002-06-13  
Acres:3.4600

**QUALIFIED CREDITS:  
HOMESTEAD**

	OWNERSHIP	ADDRESS	CITY	STATE	ZIP	DATE	AMOUNT	DEED:CONV#	JS	VALID
1	RISCH THOMAS J & BARBARA	5540 JOHNSTON RD	CELINA	OH	45822	10/30/2018	202,000	WDC : 852	<input type="checkbox"/>	<input checked="" type="checkbox"/>
2	YOUNGKER LESTER V &	5540 JOHNSTON RD	CELINA	OH	45822		0	: 0	<input type="checkbox"/>	<input type="checkbox"/>
3							0	0	<input type="checkbox"/>	<input type="checkbox"/>

X:  TTO LISTER: JO DATE: 03/11/2005 TIME: 12:00:00 AM  LETTER  LETTER REC'D GIS CODE

STREET/ROAD	TOPOGRAPHY	PU-UTILITIES-PR	NEIGHBORHOOD	INFLUENCE FACTORS	PROPERTY LOCATION	
<input checked="" type="checkbox"/> PAVED <input type="checkbox"/> GRAVEL <input type="checkbox"/> DIRT <input type="checkbox"/> SIDEWALKS <input type="checkbox"/> CURBS	<input checked="" type="checkbox"/> LEVEL <input type="checkbox"/> HIGH <input type="checkbox"/> LOW <input type="checkbox"/> ROLLING <input type="checkbox"/> STANDARD	<input type="checkbox"/> WATER <input type="checkbox"/> SEWER <input type="checkbox"/> GAS <input type="checkbox"/> ELECTRIC <input checked="" type="checkbox"/> STANDARD	<input type="checkbox"/> IMPROVING <input checked="" type="checkbox"/> STATIC <input type="checkbox"/> DECLINING <input type="checkbox"/> OLD <input type="checkbox"/> STANDARD	<input type="checkbox"/> A. NO ROAD <input type="checkbox"/> B. TOPGRHY <input type="checkbox"/> C. Ex Front <input type="checkbox"/> D. QUANTITY <input type="checkbox"/> E. SZ/SHAPE	<input type="checkbox"/> F. RESTRICT <input type="checkbox"/> G. WOOD LT <input type="checkbox"/> H. VACANCY <input type="checkbox"/> I. WATER FRONT <input type="checkbox"/> J. OTHER/CDU	5540 JOHNSTON RD, CELINA <b>COMMENT</b> TY2018:Net Gen=\$2,774.88, Other Assessment=\$0.00 DE17 DESKTOP RVW CHG: UPDATE SKETCH

**LAND COMPUTATIONS**

LAND TYPE	SIZE	M	RATE	C	INF	M	VALUE	C
HS:Home Site	AC:1	16500				16,500	0	
SM:Small Acreage	AC:2.46	6600				16,200	0	
Total Acres: 3.4600						TOTAL	32,700	0

**VALUATION SUMMARY**

VALUE YEAR	2017	2017	2014	2011				
REASON FOR CHANGE	RAPP	MISC	RAPP	RAPP				
APPRAISED	LAND	32,700	31,200	31,200	31,200			
VALUE	IMPR	176,800	164,300	142,000	142,000			
	TOTAL	209,500	195,500	173,200	173,200			
ASSESSED	LAND	11,450	10,920	10,920	10,920			
VALUE	IMPR	61,880	57,510	49,700	49,700			
	TOTAL	73,330	68,430	60,620	60,620			

OCCUPANCY	EXTERIOR	FLOOR	AREA	CONST	VALUE											
<input checked="" type="checkbox"/> SNGL FMLY	<input type="checkbox"/> WOOD	1	1733	BRK	135,520											
<input type="checkbox"/> DUPLEX	<input type="checkbox"/> STUCCO	2ND	1085	FR	38,060											
<input type="checkbox"/> TRIPLEX	<input checked="" type="checkbox"/> ALM/VYNL															
<input type="checkbox"/> CONVR	<input type="checkbox"/> CONC BLK															
<input type="checkbox"/> MOBILE HM	<input type="checkbox"/> METAL															
<input type="checkbox"/> BI/L TRI/L	<input checked="" type="checkbox"/> BRICK															
<input type="checkbox"/> MOD/MAN	<input type="checkbox"/> STONE															
ROOFING	ROOF TYPE															
<input type="checkbox"/> METAL	<input type="checkbox"/> GABLE															
<input type="checkbox"/> SLT/TLE	<input checked="" type="checkbox"/> HIP															
<input checked="" type="checkbox"/> SHINGLES	<input type="checkbox"/> GAMBREL															
<input type="checkbox"/> SHAKES	<input type="checkbox"/> MANSARD															
<input type="checkbox"/> COMPOSITE	<input type="checkbox"/> FLAT															
		BSMT	1378		17,910											
<b>SUBTOTAL</b>					<b>191,490</b>											
<b>FLOORS</b>	<b>B 1 2 3 U</b>	<b>MULTI-FAMILY #</b>	<b>0</b>		<b>0</b>											
CONCRETE	<input checked="" type="checkbox"/> <input type="checkbox"/> <input type="checkbox"/> <input type="checkbox"/> <input type="checkbox"/>	BSMT FINISH	512 S.F.		6,660											
WOOD	<input type="checkbox"/> <input type="checkbox"/> <input type="checkbox"/> <input type="checkbox"/> <input type="checkbox"/>	FIREPLACE #	1		4,000											
TILE/COMPO	<input type="checkbox"/> <input checked="" type="checkbox"/> <input type="checkbox"/> <input type="checkbox"/> <input type="checkbox"/>	HEATING	0 S.F.		0											
CARPET	<input type="checkbox"/> <input checked="" type="checkbox"/> <input type="checkbox"/> <input type="checkbox"/> <input type="checkbox"/>	AIR COND	0 S.F.		0											
<b>INT. FINISH</b>	<b>B 1 2 3 U</b>	PLUMBING #	3		3,300											
PLASTER/DW	<input checked="" type="checkbox"/> <input checked="" type="checkbox"/> <input type="checkbox"/> <input type="checkbox"/> <input type="checkbox"/>	GARAGES & CARPORTS			11,700											
PANELING	<input type="checkbox"/> <input type="checkbox"/> <input type="checkbox"/> <input type="checkbox"/> <input type="checkbox"/>	EXTRA FEATURES			4,300											
UNFINISHED	<input checked="" type="checkbox"/> <input type="checkbox"/> <input type="checkbox"/> <input type="checkbox"/> <input type="checkbox"/>	<b>SUBTOTAL</b>			<b>221,450</b>											
<b>ACCOMMODATIONS</b>		GRADE FACTOR			105 %											
# OF ROOMS	3 3	<b>UNADJUSTED VALUE</b>			<b>232,520</b>											
BEDROOMS		3														
FIREPLACES		1														
<b>HEAT &amp; AC</b>	<b>B 1 2 3 U</b>	FACTOR			100 %											
NO HEAT	<input type="checkbox"/> <input type="checkbox"/> <input type="checkbox"/> <input type="checkbox"/> <input type="checkbox"/>	<b>OCCUPANCY ST.HT SIZE AREA GRADE PRICE AGE REMD CND UNADJ VAL PHYS PHYS VAL FUNC TRUE VAL</b>														
CTRL HEAT	<input type="checkbox"/> <input type="checkbox"/> <input type="checkbox"/> <input type="checkbox"/> <input type="checkbox"/>	DWELLING	2	SK	2,818	C+			1977		A	232,520	28	167,410		167,400
HW/STEAM	<input type="checkbox"/> <input type="checkbox"/> <input type="checkbox"/> <input type="checkbox"/> <input type="checkbox"/>	1 Pole Bldg	10	27x55	1,485	C	8.75	1991			A	12,990	47	6,880		6,900
ELECTRIC	<input type="checkbox"/> <input type="checkbox"/> <input type="checkbox"/> <input type="checkbox"/> <input type="checkbox"/>	2 Pole Bldg	10	24x32	768	C	10.00	1977			A	7,680	67	2,530		2,500
HEAT PUMP	<input checked="" type="checkbox"/> <input checked="" type="checkbox"/> <input type="checkbox"/> <input type="checkbox"/> <input type="checkbox"/>	3														
FLR/WALL	<input type="checkbox"/> <input type="checkbox"/> <input type="checkbox"/> <input type="checkbox"/> <input type="checkbox"/>	4														
STVE/SPCE	<input type="checkbox"/> <input type="checkbox"/> <input type="checkbox"/> <input type="checkbox"/> <input type="checkbox"/>	5														
GEO THERMAL	<input type="checkbox"/> <input type="checkbox"/> <input type="checkbox"/> <input type="checkbox"/> <input type="checkbox"/>	6														
OUTSIDE	<input type="checkbox"/> <input type="checkbox"/> <input type="checkbox"/> <input type="checkbox"/> <input type="checkbox"/>	7														
CTRL A/C	<input type="checkbox"/> <input type="checkbox"/> <input type="checkbox"/> <input type="checkbox"/> <input type="checkbox"/>	8														
<b>PLUMBING</b>	<b>BASE</b> <input checked="" type="checkbox"/>	9														
X FULL BATH		10														
X HALF BATH		11														
X FIXTURES																

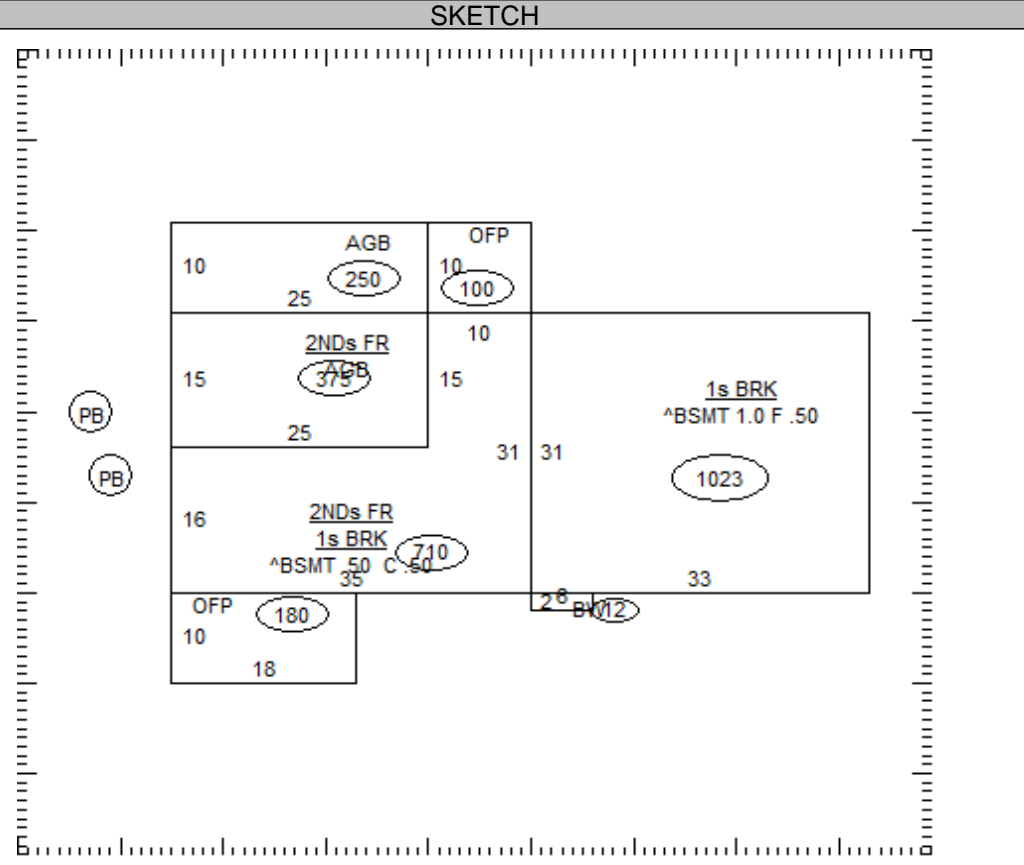

02-001600.0000

TOTAL 176,800

**COMMENTS**

Dwelling has an Economic Factor of 100%