

1 OF 2		
PROP. CLASS		
5	1	0
NEIGHBORHOOD		
009015-R150		
M	05	
B	01	
C	11	

01-019100.0100

**SCHWARTZ ENOS C**  
 SCHWARTZ ENOS C  
 1759 ROCKFORD WEST RD  
 ROCKFORD, OH 45882

**LEGAL INFORMATION**  
 SW COR NE

RTS: 001-04-15  
 Acres: 1.9990

	OWNERSHIP	ADDRESS	CITY	STATE	ZIP	DATE	AMOUNT	DEED:CONV#	JS	VALID
1	SCHWARTZ ENOS C	1759 ROCKFORD WEST RD	ROCKFORD	OH	45882	08/29/2016	67,500	WDC : 589	<input type="checkbox"/>	<input checked="" type="checkbox"/>
2	SMITH DALE & NORMA JEAN	1779 ROCKFORD WEST RD	ROCKFORD	OH	45882	02/17/2012	0	QCE : X : 0	<input type="checkbox"/>	<input type="checkbox"/>
3	NICHOLS NORMA J	1759 ROCKFORD WEST RD	ROCKFORD	OH	45882	05/16/2007	0	QCE : X : 0	<input type="checkbox"/>	<input type="checkbox"/>

X:  TTO LISTER: JK DATE: 01/28/2019 TIME: 12:00:00 AM  LETTER  LETTER REC'D GIS CODE

STREET/ROAD	TOPOGRAPHY	PU-UTILITIES-PR	NEIGHBORHOOD	INFLUENCE FACTORS				PROPERTY LOCATION
<input checked="" type="checkbox"/> PAVED	<input checked="" type="checkbox"/> LEVEL	<input type="checkbox"/> WATER	<input checked="" type="checkbox"/> IMPROVING	<input type="checkbox"/> A. NO ROAD	<input type="checkbox"/> F. RESTRICT	1759 ROCKFORD WEST RD, ROCKFORD		
<input type="checkbox"/> GRAVEL	<input type="checkbox"/> HIGH	<input type="checkbox"/> SEWER	<input checked="" type="checkbox"/> STATIC	<input type="checkbox"/> B. TOPGRHY	<input type="checkbox"/> G. WOOD LT	COMMENT		
<input type="checkbox"/> DIRT	<input type="checkbox"/> LOW	<input type="checkbox"/> GAS	<input type="checkbox"/> DECLINING	<input type="checkbox"/> C. Ex Front	<input type="checkbox"/> H. VACANCY	TY2018:Net Gen=\$1,218.32, Other		
<input type="checkbox"/> SIDEWALKS	<input type="checkbox"/> ROLLING	<input checked="" type="checkbox"/> ELECTRIC	<input type="checkbox"/> OLD	<input type="checkbox"/> D. QUANTITY	<input type="checkbox"/> I. WATER FRONT	Assessment=\$121.28		
<input type="checkbox"/> CURBS	<input type="checkbox"/> STANDARD	<input type="checkbox"/> STANDARD	<input type="checkbox"/> STANDARD	<input type="checkbox"/> E. SZ/SHAPE	<input type="checkbox"/> J. OTHER/CDU	NC20 CHK COMPL OF DWLG		

LAND COMPUTATIONS						
LAND TYPE	SIZE	M	RATE	C	INF	M VALUE C
HS:Home Site	AC:1	16500				16,500 0
SM:Small Acreage	AC:0.999	7000				7,000 0
Total Acres: 1.9990					TOTAL	23,500 0

DE19 TTO; ADD DWLG @ 35%, RMV OLD DWLG  
 DE18 ADD PB & CNPY/TTO  
 DE17 RMV INC ON SHED/ NOH  
 DE17 DESKTOP RVW CHG:minor sk cor  
 DE16 NOH/ ADD SHED, COR OUTBLDGS

VALUATION SUMMARY									
VALUE YEAR	2019	2018	2017	2017	2016	2014	2014	2013	
REASON FOR CHANGE	NC	NC	NC	MISC	NC	REMB	RAPP	MISC	
APPRAISED	23,500	23,500	23,500	20,200	20,200	20,200	20,200	22,000	
VALUE	64,700	66,900	48,700	38,500	38,000	36,500	40,500	43,800	
	<u>TOTAL</u>	90,400	72,200	58,700	58,200	56,700	60,700	65,800	
ASSESSED	8,230	8,230	8,230	7,070	7,070	7,070	7,070	7,700	
VALUE	22,650	23,420	17,050	13,480	13,300	12,780	14,180	15,330	
	<u>TOTAL</u>	31,650	25,280	20,550	20,370	19,850	21,250	23,030	

OCCUPANCY	EXTERIOR	FLOOR	AREA	CONST	VALUE
<input checked="" type="checkbox"/> SNGL FMLY	<input type="checkbox"/> WOOD	1	1456	FR	114,530
<input type="checkbox"/> DUPLEX	<input type="checkbox"/> STUCCO	2ND	800	FR	30,210
<input type="checkbox"/> TRIPLEX	<input checked="" type="checkbox"/> ALM/VYNL				
<input type="checkbox"/> CONVR	<input type="checkbox"/> CONC BLK				
<input type="checkbox"/> MOBILE HM	<input type="checkbox"/> METAL				
<input type="checkbox"/> BI/L TRI/L	<input type="checkbox"/> BRICK				
<input type="checkbox"/> MOD/MAN	<input type="checkbox"/> STONE				

ROOFING	ROOF TYPE
<input type="checkbox"/> METAL	<input checked="" type="checkbox"/> GABLE
<input type="checkbox"/> SLT/TLE	<input type="checkbox"/> HIP
<input checked="" type="checkbox"/> SHINGLES	<input type="checkbox"/> GAMBREL
<input type="checkbox"/> SHAKES	<input type="checkbox"/> MANSARD
<input type="checkbox"/> COMPOSITE	<input type="checkbox"/> FLAT

FLOORS	B	1	2	3	U
CONCRETE	<input type="checkbox"/>	<input type="checkbox"/>	<input type="checkbox"/>	<input type="checkbox"/>	<input type="checkbox"/>
WOOD	<input type="checkbox"/>	<input checked="" type="checkbox"/>	<input type="checkbox"/>	<input type="checkbox"/>	<input type="checkbox"/>
TILE/COMPO	<input type="checkbox"/>	<input type="checkbox"/>	<input type="checkbox"/>	<input type="checkbox"/>	<input type="checkbox"/>
CARPET	<input type="checkbox"/>	<input type="checkbox"/>	<input type="checkbox"/>	<input type="checkbox"/>	<input type="checkbox"/>

INT. FINISH	B	1	2	3	U
PLASTER/DW	<input type="checkbox"/>	<input checked="" type="checkbox"/>	<input type="checkbox"/>	<input type="checkbox"/>	<input type="checkbox"/>
PANELING	<input type="checkbox"/>	<input type="checkbox"/>	<input type="checkbox"/>	<input type="checkbox"/>	<input type="checkbox"/>
UNFINISHED	<input checked="" type="checkbox"/>	<input type="checkbox"/>	<input type="checkbox"/>	<input type="checkbox"/>	<input type="checkbox"/>

ACCOMMODATIONS					
# OF ROOMS	3				
BEDROOMS	1				
FIREPLACES					
HEAT & AC	B	1	2	3	U
NO HEAT	<input type="checkbox"/>	<input checked="" type="checkbox"/>	<input checked="" type="checkbox"/>	<input type="checkbox"/>	<input type="checkbox"/>
CTRL HEAT	<input type="checkbox"/>	<input type="checkbox"/>	<input type="checkbox"/>	<input type="checkbox"/>	<input type="checkbox"/>
HW/STEAM	<input type="checkbox"/>	<input type="checkbox"/>	<input type="checkbox"/>	<input type="checkbox"/>	<input type="checkbox"/>
ELECTRIC	<input type="checkbox"/>	<input type="checkbox"/>	<input type="checkbox"/>	<input type="checkbox"/>	<input type="checkbox"/>
HEAT PUMP	<input type="checkbox"/>	<input type="checkbox"/>	<input type="checkbox"/>	<input type="checkbox"/>	<input type="checkbox"/>
FLR/WALL	<input type="checkbox"/>	<input type="checkbox"/>	<input type="checkbox"/>	<input type="checkbox"/>	<input type="checkbox"/>
STVE/SPCE	<input type="checkbox"/>	<input checked="" type="checkbox"/>	<input checked="" type="checkbox"/>	<input type="checkbox"/>	<input type="checkbox"/>
GEOTHERMAL	<input type="checkbox"/>	<input type="checkbox"/>	<input type="checkbox"/>	<input type="checkbox"/>	<input type="checkbox"/>
OUTSIDE	<input type="checkbox"/>	<input type="checkbox"/>	<input type="checkbox"/>	<input type="checkbox"/>	<input type="checkbox"/>
CTRL A/C	<input type="checkbox"/>	<input type="checkbox"/>	<input type="checkbox"/>	<input type="checkbox"/>	<input type="checkbox"/>

BSMT	AREA	VALUE
BSMT	1120	14,560
<b>SUBTOTAL</b>		<b>159,300</b>

MULTI-FAMILY #	0	0
BSMT FINISH	0 S.F.	0
FIREPLACE #	0	0
HEATING	2,256 S.F.	-5,640
AIR COND	0 S.F.	0
PLUMBING #	0	-5,500
GARAGES & CARPORTS		0
EXTRA FEATURES		0
<b>SUBTOTAL</b>		<b>148,160</b>
GRADE FACTOR		100 %
<b>UNADJUSTED VALUE</b>		<b>148,160</b>
FACTOR		100 %

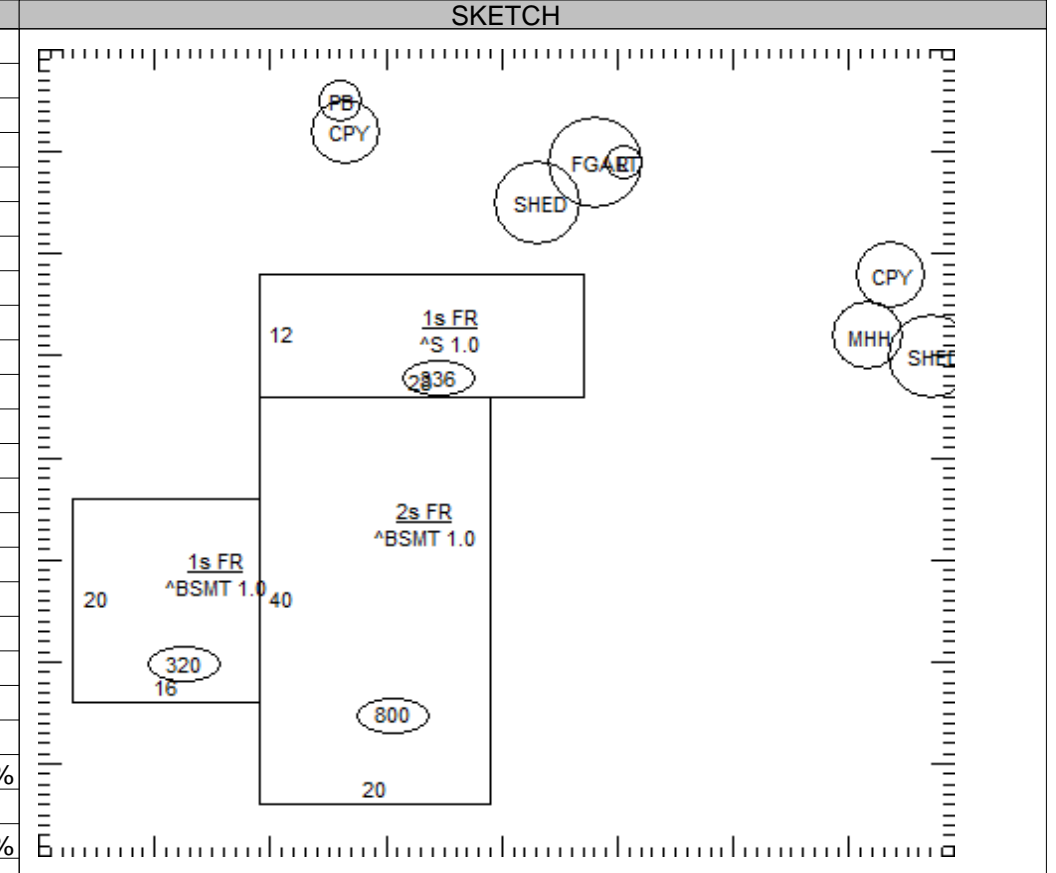

OCCUPANCY	ST.HT	SIZE	AREA	GRADE	PRICE	AGE	REMD	CND	UNADJ VAL	PHYS	PHYS VAL	FUNC	TRUE VAL
DWELLING	2	SK	2,256	C		2018		G	148,160	1	146,680	INC65	38,500
1 MH Hookup	SV*	70x14	980	C		1970		A	4,000				4,000
2 Canopy		10x24	240	D	4.32	1999		F	1,040	40	620		600
3 Gar - Frame	9	17x26	442	D	12.64	1900		F	5,590	95	280		300
4 Shed		10x12	120	C		2000		A		29			0
5 Shed		24x28	672	D	4.80	2015		A	3,230	4	3,100		3,100
6 Lean - To	7	10x26	260	C	3.20	1900		F	830	95	40		0
7 Pole Bldg		32x48	1,536	C	10.75	2017		A	16,510	2	16,180		16,200
8 Canopy		8x48	384	C	5.40	2017		A	2,070	2	2,030		2,000
9													
10													
11													

01-019100.0100 \* Value Override Item TOTAL 64,700

COMMENTS

>>OB Features: 1.7 <Add Concrete Floor>  
 Dwelling has an Economic Factor of 75%

2 OF 2		
PROP. CLASS		
5	1	0
NEIGHBORHOOD		
009015-R150		
M	05	
B	01	
C	11	

BLACKCREEK TWP / PARKWAY SD

01-15-200-002

01-019100.0100

**LEGAL INFORMATION**

SW COR NE

RTS: 001-04-15  
Acres: 1.9990

**SCHWARTZ ENOS C**  
SCHWARTZ ENOS C  
1759 ROCKFORD WEST RD  
ROCKFORD, OH 45882

	OWNERSHIP	ADDRESS	CITY	STATE	ZIP	DATE	AMOUNT	DEED:CONV#	JS	VALID
1	NICHOLS JOHN & NORMA	1759 ROCKFORD WEST RD	ROCKFORD	OH	45882-8841		0	:0	<input type="checkbox"/>	<input type="checkbox"/>
2							0	0	<input type="checkbox"/>	<input type="checkbox"/>
3							0	0	<input type="checkbox"/>	<input type="checkbox"/>

X:  TTO    LISTER: JK    DATE: 01/28/2019    TIME: 12:00:00 AM     LETTER     LETTER REC'D    GIS CODE

STREET/ROAD	TOPOGRAPHY	PU-UTILITIES-PR	NEIGHBORHOOD	INFLUENCE FACTORS	PROPERTY LOCATION	
<input checked="" type="checkbox"/> PAVED <input type="checkbox"/> GRAVEL <input type="checkbox"/> DIRT <input type="checkbox"/> SIDEWALKS <input type="checkbox"/> CURBS	<input checked="" type="checkbox"/> LEVEL <input type="checkbox"/> HIGH <input type="checkbox"/> LOW <input type="checkbox"/> ROLLING <input type="checkbox"/> STANDARD	<input type="checkbox"/> WATER <input type="checkbox"/> SEWER <input type="checkbox"/> GAS <input checked="" type="checkbox"/> ELECTRIC <input type="checkbox"/> STANDARD	<input type="checkbox"/> IMPROVING <input checked="" type="checkbox"/> STATIC <input type="checkbox"/> DECLINING <input type="checkbox"/> OLD <input type="checkbox"/> STANDARD	<input type="checkbox"/> A. NO ROAD <input type="checkbox"/> B. TOPGRHY <input type="checkbox"/> C. Ex Front <input type="checkbox"/> D. QUANTITY <input type="checkbox"/> E. SZ/SHAPE	<input type="checkbox"/> F. RESTRICT <input type="checkbox"/> G. WOOD LT <input type="checkbox"/> H. VACANCY <input type="checkbox"/> I. WATER FRONT <input type="checkbox"/> J. OTHER/CDU	1759 ROCKFORD WEST RD, ROCKFORD COMMENT

LAND COMPUTATIONS							
LAND TYPE	SIZE	M	RATE	C	INF	M	VALUE C
Total Acres: 1.9990					TOTAL	23,500	0

**VALUATION SUMMARY**

VALUE YEAR	2011	2010					
REASON FOR CHANGE	RAPP	MISC					
APPRaised	22,000	22,000					
VALUE	43,800	43,800					
	65,800	65,800					
ASSESSED	7,700	7,700					
VALUE	15,330	15,330					
	23,030	23,030					

OCCUPANCY	EXTERIOR	FLOOR	AREA	CONST	VALUE
<input type="checkbox"/> SNGL FMLY	<input type="checkbox"/> WOOD				
<input type="checkbox"/> DUPLEX	<input type="checkbox"/> STUCCO				
<input type="checkbox"/> TRIPLEX	<input type="checkbox"/> ALM/VYNL				
<input type="checkbox"/> CONVR	<input type="checkbox"/> CONC BLK				
<input type="checkbox"/> MOBILE HM	<input type="checkbox"/> METAL				
<input type="checkbox"/> BI/L TRI/L	<input type="checkbox"/> BRICK				
<input type="checkbox"/> MOD/MAN	<input type="checkbox"/> STONE				

ROOFING	ROOF TYPE
<input type="checkbox"/> METAL	<input type="checkbox"/> GABLE
<input type="checkbox"/> SLT/TLE	<input type="checkbox"/> HIP
<input type="checkbox"/> SHINGLES	<input type="checkbox"/> GAMBREL
<input type="checkbox"/> SHAKES	<input type="checkbox"/> MANSARD
<input type="checkbox"/> COMPOSITE	<input type="checkbox"/> FLAT

FLOORS	B	1	2	3	U		VALUE
CONCRETE	<input type="checkbox"/>	<input type="checkbox"/>	<input type="checkbox"/>	<input type="checkbox"/>	<input type="checkbox"/>	MULTI-FAMILY #	0
WOOD	<input type="checkbox"/>	<input type="checkbox"/>	<input type="checkbox"/>	<input type="checkbox"/>	<input type="checkbox"/>	BSMT FINISH	0 S.F.
TILE/COMPO	<input type="checkbox"/>	<input type="checkbox"/>	<input type="checkbox"/>	<input type="checkbox"/>	<input type="checkbox"/>	FIREPLACE #	0
CARPET	<input type="checkbox"/>	<input type="checkbox"/>	<input type="checkbox"/>	<input type="checkbox"/>	<input type="checkbox"/>	HEATING	0 S.F.
						AIR COND	0 S.F.
						PLUMBING #	0
						GARAGES & CARPORTS	0
						EXTRA FEATURES	0
						SUBTOTAL	0
						GRADE FACTOR	%
						UNADJUSTED VALUE	0
						FACTOR	%

ACCOMMODATIONS	B	1	2	3	U		VALUE
# OF ROOMS							
BEDROOMS							
FIREPLACES							
HEAT & AC							
NO HEAT	<input type="checkbox"/>	<input type="checkbox"/>	<input type="checkbox"/>	<input type="checkbox"/>	<input type="checkbox"/>		
CTRL HEAT	<input type="checkbox"/>	<input type="checkbox"/>	<input type="checkbox"/>	<input type="checkbox"/>	<input type="checkbox"/>		
HW/STEAM	<input type="checkbox"/>	<input type="checkbox"/>	<input type="checkbox"/>	<input type="checkbox"/>	<input type="checkbox"/>		
ELECTRIC	<input type="checkbox"/>	<input type="checkbox"/>	<input type="checkbox"/>	<input type="checkbox"/>	<input type="checkbox"/>		
HEAT PUMP	<input type="checkbox"/>	<input type="checkbox"/>	<input type="checkbox"/>	<input type="checkbox"/>	<input type="checkbox"/>		
FLR/WALL	<input type="checkbox"/>	<input type="checkbox"/>	<input type="checkbox"/>	<input type="checkbox"/>	<input type="checkbox"/>		
STVE/SPCE	<input type="checkbox"/>	<input type="checkbox"/>	<input type="checkbox"/>	<input type="checkbox"/>	<input type="checkbox"/>		
GEO THERMAL	<input type="checkbox"/>	<input type="checkbox"/>	<input type="checkbox"/>	<input type="checkbox"/>	<input type="checkbox"/>		
OUTSIDE	<input type="checkbox"/>	<input type="checkbox"/>	<input type="checkbox"/>	<input type="checkbox"/>	<input type="checkbox"/>		
CTRL A/C	<input type="checkbox"/>	<input type="checkbox"/>	<input type="checkbox"/>	<input type="checkbox"/>	<input type="checkbox"/>		
PLUMBING						BASE	<input type="checkbox"/>
X FULL BATH							
X HALF BATH							
X FIXTURES							

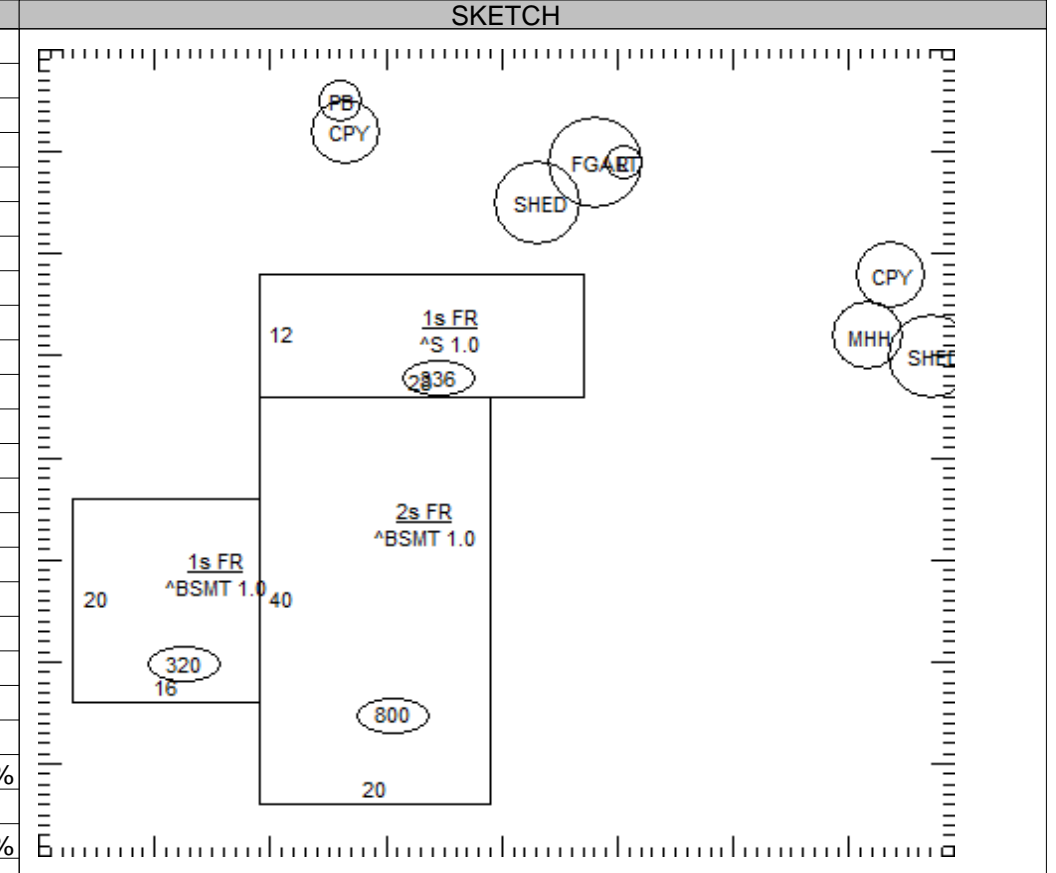

OCCUPANCY	ST.HT	SIZE	AREA	GRADE	PRICE	AGE	REMD	CND	UNADJ VAL	PHYS	PHYS VAL	FUNC	TRUE VAL
DWELLING		SK											
1													
2													
3													
4													
5													
6													
7													
8													
9													
10													
11													

01-019100.0100	TOTAL	0
----------------	-------	---

COMMENTS